

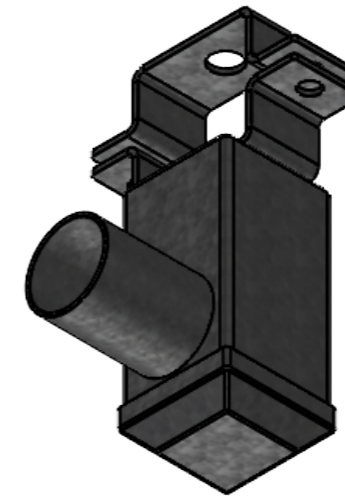

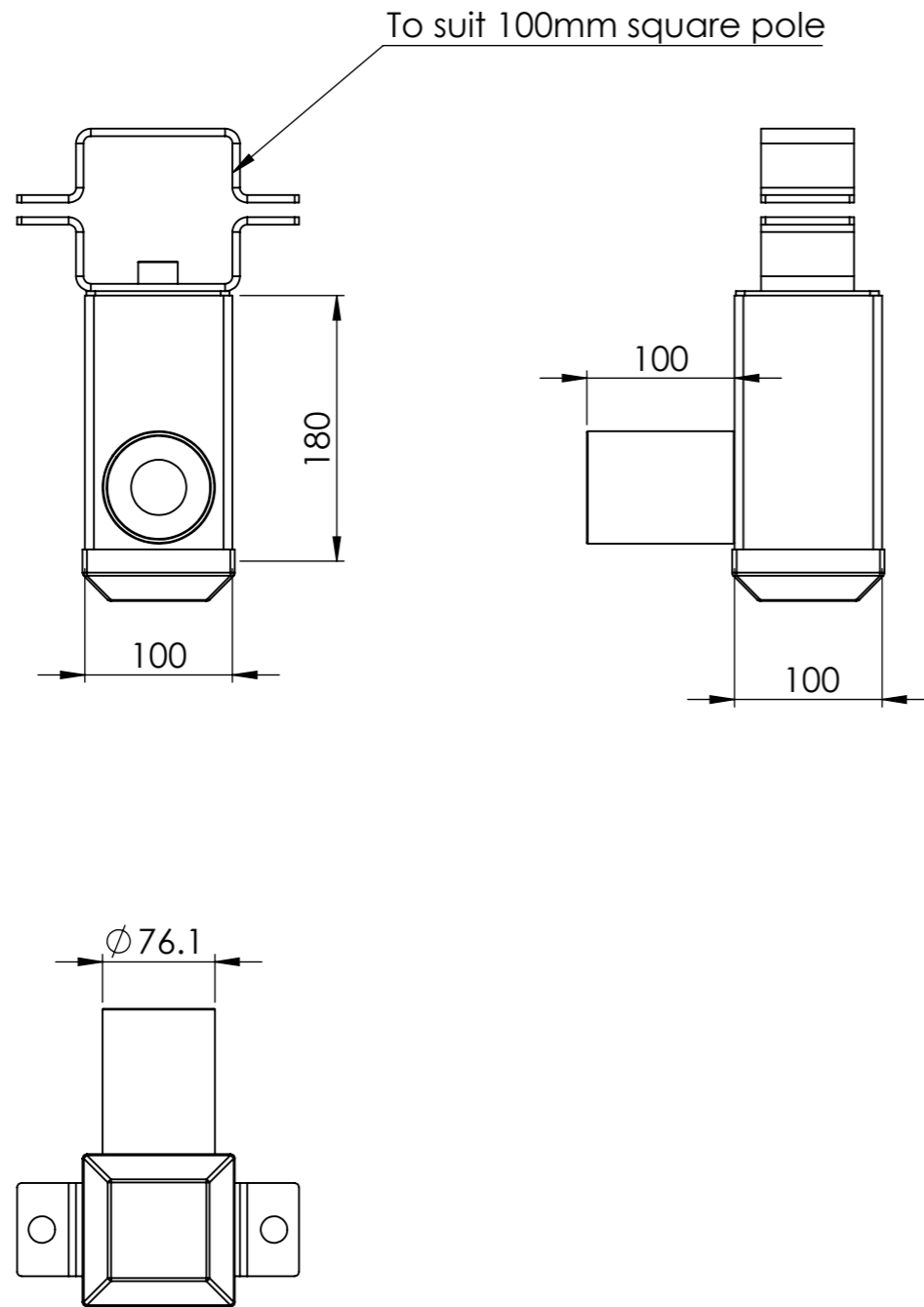

SB00211A02	Single spigot bracket for 100mm square pole
SB00211A03	Double spigot bracket for 100mm square pole, 350mm ctrs
SB00211A04	Triple spigot bracket for 100mm square pole
SB00211A05	Single spigot bracket for Octagonal pole
SB00211A06	Double spigot bracket for Octagonal pole
SB00211A07	Triple spigot bracket for Octagonal pole
SB00211A08	Double spigot bracket for pole top mounting
SB00211A09	Triple spigot bracket for pole top mounting, 500mm ctrs
SB00211A11	Single spigot bracket for wall mounting 180mm
SB00211A12	Double spigot bracket for wall mounting, parallel to wall
SB00211P13	Triple spigot bracket for wall mounting, parallel to wall
SB00211A14	Single spigot pole top mount 600mm offset
SB00211A16	Single spigot wall mount 1.0m offset
SB00211A21	Double spigot bracket for 100mm square pole, 500mm ctrs
SB00211A23	Single spigot bracket for wall mounting 300mm
SB00211A24	Triple spigot bracket for pole top mounting, 700mm ctrs
SB00211A25	Quadruple spigot bracket for pole top mounting
SB00211A26	Wall mount right angle bracket single spigot left hand 650mm
SB00211A27	Wall mount right angle bracket single spigot right hand 650mm
SB00211A29	Pole top mount 1.5" NPT thread 350mm
SB00211A30	Pole top mount 1.5" NPT thread 350mm with single spigot
SB00211A31	Pole top mount dual bullet camera
SB00211A33	Pole top mount PTZ
SB00211A34	Wall mount 1.5" NPT 300mm
SB00211A35	Pole top mount PTZ 45-degree angle
SB00211A38	Wall mount single spigot 500mm
SB00211A41	Wall mount single spigot 180mm extended spigot 220mm
SB00211A43	60mm pole mount single spigot 300mm extended spigot 220mm
SB00211A44	100mm square pole mount double spigot 1.7m long
SB00211A46	Single spigot bracket for wall mounting 180mm spigot extended to 900mm
SB00211A48	Pole top mount Dual camera 375mm
SB00211A50	Wall mount single spigot with 1.5 NPT thread dropper 500mm
SB00211A52	200mm square pole mount single spigot
SB00211A54	Pole top mount double spigot with double 1.5 NPT droppers 800mm
SB00211A60	Wall mount single spigot with 1.5" NPT dropper 375mm
SB00211A62	Wall mount with 1.5" NPT dropper 375mm
SB00211A64	Wall mount dual camera 375mm
SB00211A66	100mm square pole mount with 1.5" NPT dropper 250mm
SB00211A68	Slim line wall mount single spigot 300mm
SB00211A70	Pole top mount 400mm height extended, 1.5" NPT dropper 350mm
SB00211A72	Single spigot wall mount, slim line, extended mount plate 180mm
SB00211A76	Wall mount hinged, +/- 90° 1.5" NPT dropper 2.0m
SB00217A05	Roof mount 15° mount box for SMW5 wedge housing
SB00217A06	Roof mount 50mm drop box for SMW5 wedge housing
SB00217A07	Offset roof mount bracket to drop SMW5 wedge housing 300mm
SB00217A08	Centralised roof mount bracket to drop SMW5 wedge housing 300mm
SB00217A10	Double spigot, 300mm offset, 450mm to suit 100mm square pole



UNLESS OTHERWISE SPECIFIED: DIMENSIONS ARE IN MILLIMETERS	PROPRIETARY AND CONFIDENTIAL THE INFORMATION CONTAINED IN THIS DRAWING IS THE SOLE PROPERTY OF SEE SECURITY PTY LTD. ANY REPRODUCTION IN PART OR AS A WHOLE WITHOUT THE WRITTEN PERMISSION OF SEE SECURITY PTY LTD IS PROHIBITED.	DEBUR AND BREAK SHARP EDGES	DO NOT SCALE DRAWING	REVISION
FINISH:			 SEE SECURITY SECURITY & EQUIPMENT ENCLOSURES	
NAME	SIGNATURE	DATE		
DRAWN	ADC	14/10/2016	DWG NO.	SB00211A02
MATERIAL:	Weight			A3
SB00211A02	4kg		SCALE:1:5	SHEET 1 OF 84

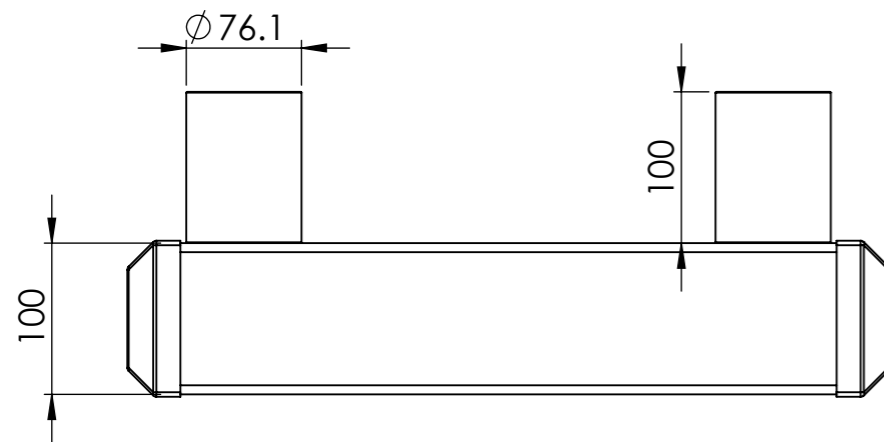
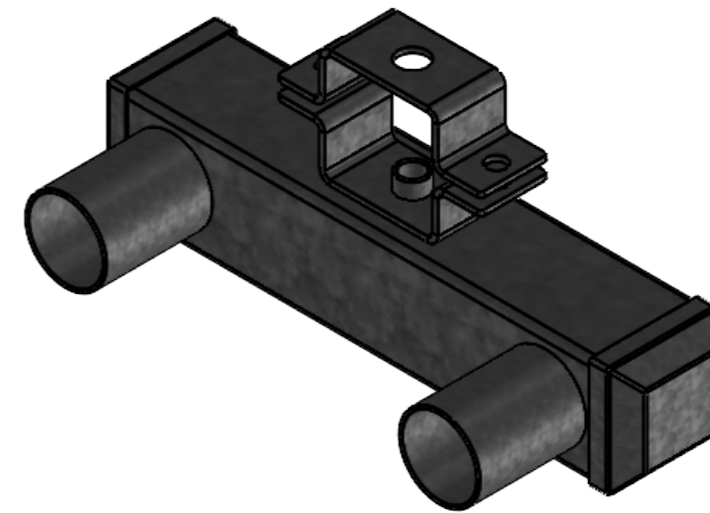
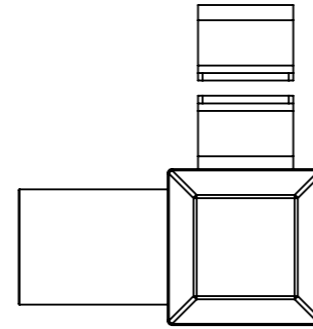
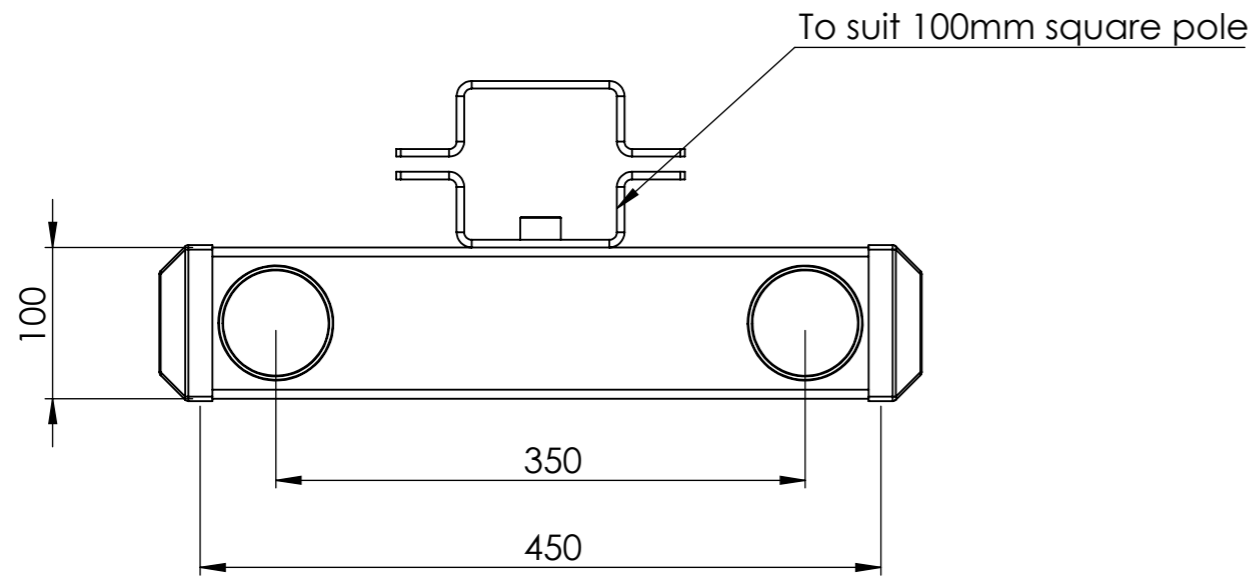

UNLESS OTHERWISE SPECIFIED: DIMENSIONS ARE IN MILLIMETERS	PROPRIETARY AND CONFIDENTIAL THE INFORMATION CONTAINED IN THIS DRAWING IS THE SOLE PROPERTY OF SEE SECURITY PTY LTD. ANY REPRODUCTION IN PART OR AS A WHOLE WITHOUT THE WRITTEN PERMISSION OF SEE SECURITY PTY LTD IS PROHIBITED.	DEBUR AND BREAK SHARP EDGES	DO NOT SCALE DRAWING	REVISION
FINISH:			 SEE SECURITY SECURITY & EQUIPMENT ENCLOSURES	
NAME	SIGNATURE	DATE		
DRAWN	ADC	14/10/2016	DWG NO.	A3
MATERIAL:	Weight		SB00211A03	
Steel galvanised	6.7kg		SCALE:1:5	SHEET 2 OF 84

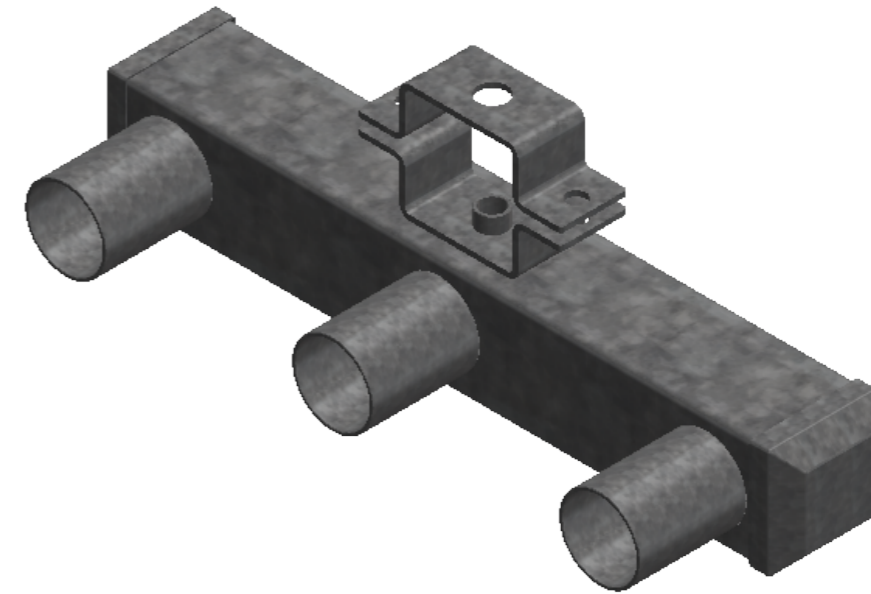
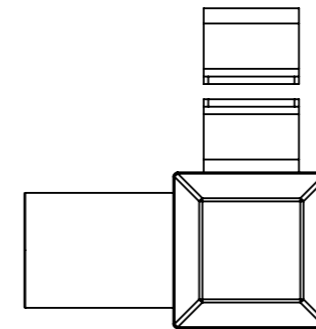
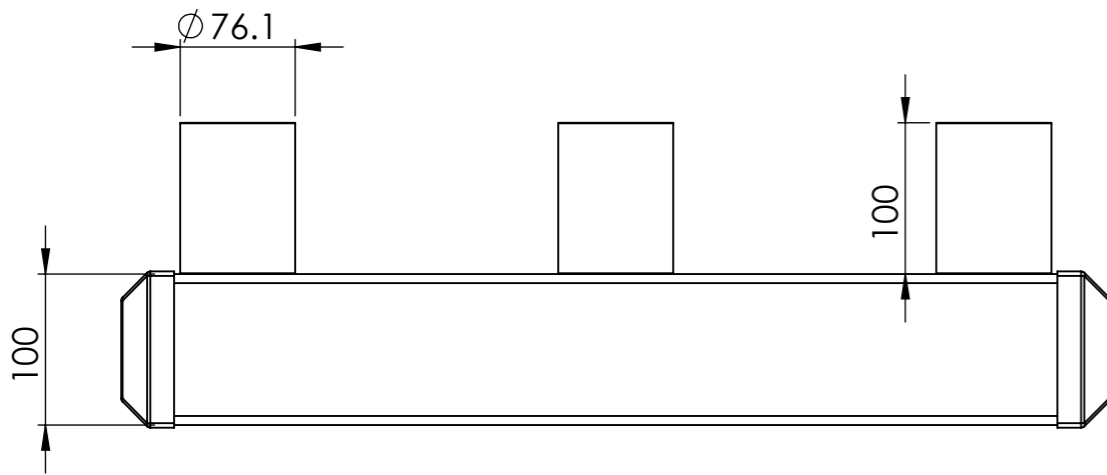
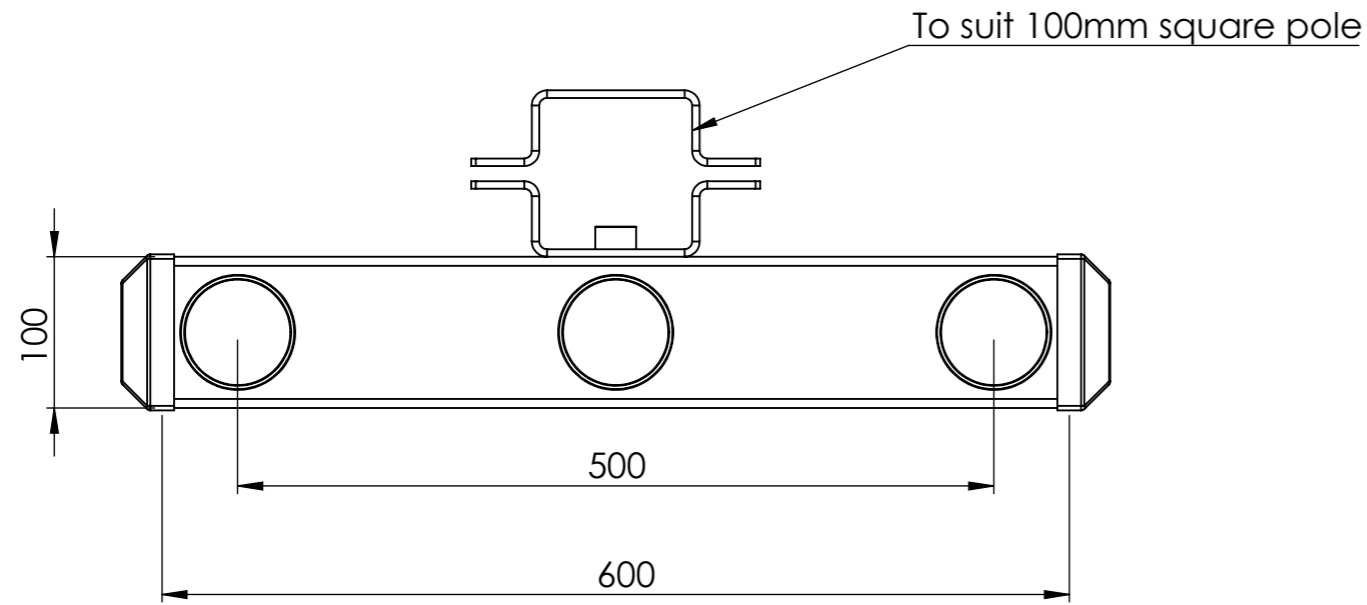

UNLESS OTHERWISE SPECIFIED: DIMENSIONS ARE IN MILLIMETERS	PROPRIETARY AND CONFIDENTIAL THE INFORMATION CONTAINED IN THIS DRAWING IS THE SOLE PROPERTY OF SEE SECURITY PTY LTD. ANY REPRODUCTION IN PART OR AS A WHOLE WITHOUT THE WRITTEN PERMISSION OF SEE SECURITY PTY LTD IS PROHIBITED.	DEBUR AND BREAK SHARP EDGES	DO NOT SCALE DRAWING	REVISION
FINISH:			 SEE SECURITY SECURITY & EQUIPMENT ENCLOSURES	
NAME	SIGNATURE	DATE		
DRAWN	ADC	14/10/2016	DWG NO.	A3
MATERIAL:	Weight		SB00211A04	
Steel galvanised	8.5kg		SCALE:1:5	SHEET 3 OF 84

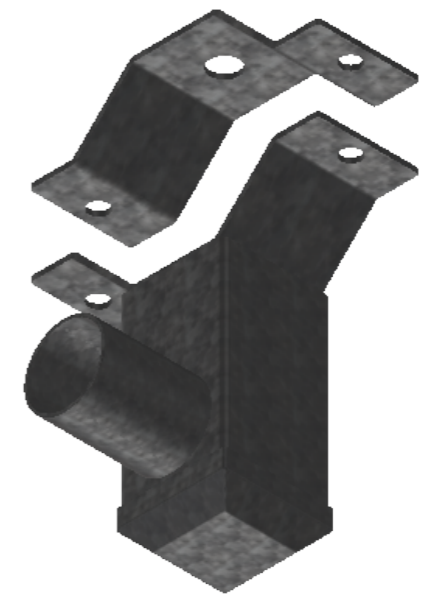
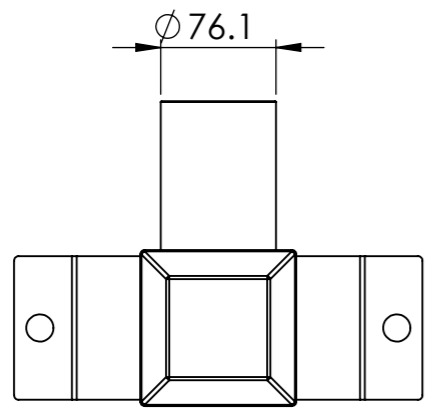
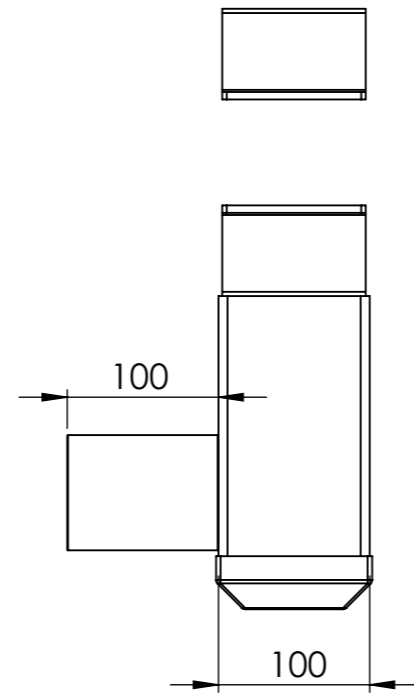
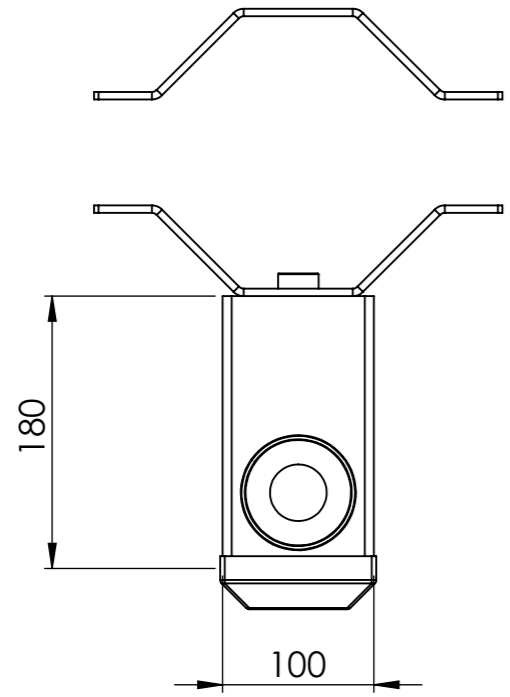

UNLESS OTHERWISE SPECIFIED: DIMENSIONS ARE IN MILLIMETERS	PROPRIETARY AND CONFIDENTIAL THE INFORMATION CONTAINED IN THIS DRAWING IS THE SOLE PROPERTY OF SEE SECURITY PTY LTD. ANY REPRODUCTION IN PART OR AS A WHOLE WITHOUT THE WRITTEN PERMISSION OF SEE SECURITY PTY LTD IS PROHIBITED.	DEBUR AND BREAK SHARP EDGES	DO NOT SCALE DRAWING	REVISION
FINISH:			 SEE SECURITY SECURITY & EQUIPMENT ENCLOSURES	
NAME	SIGNATURE	DATE		
DRAWN	ADC	14/10/2016	DWG NO.	A3
MATERIAL:	Weight		SB00211A05	
Steel galvanised	4.7kg		SCALE:1:5	SHEET 4 OF 84

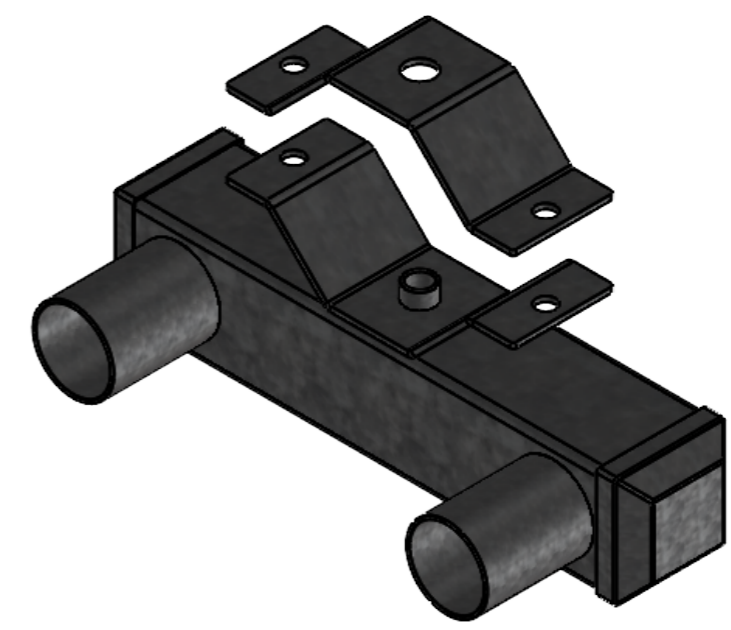
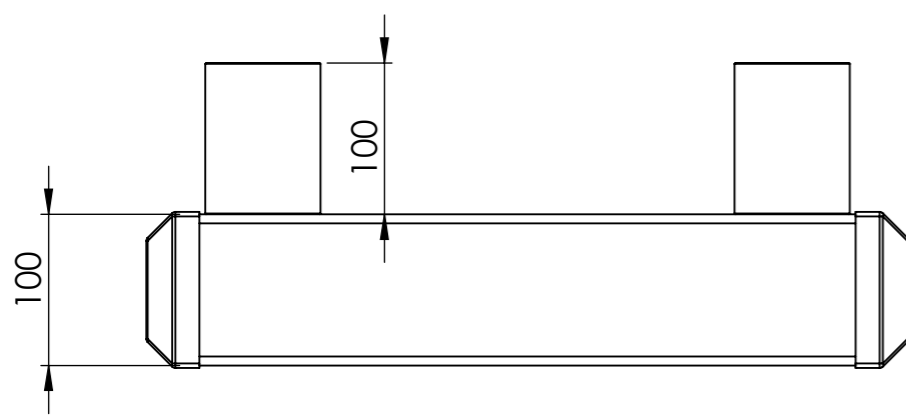
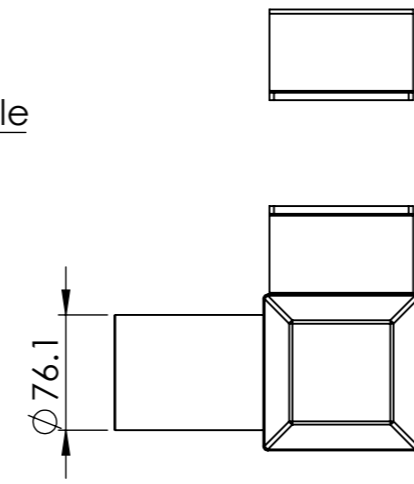
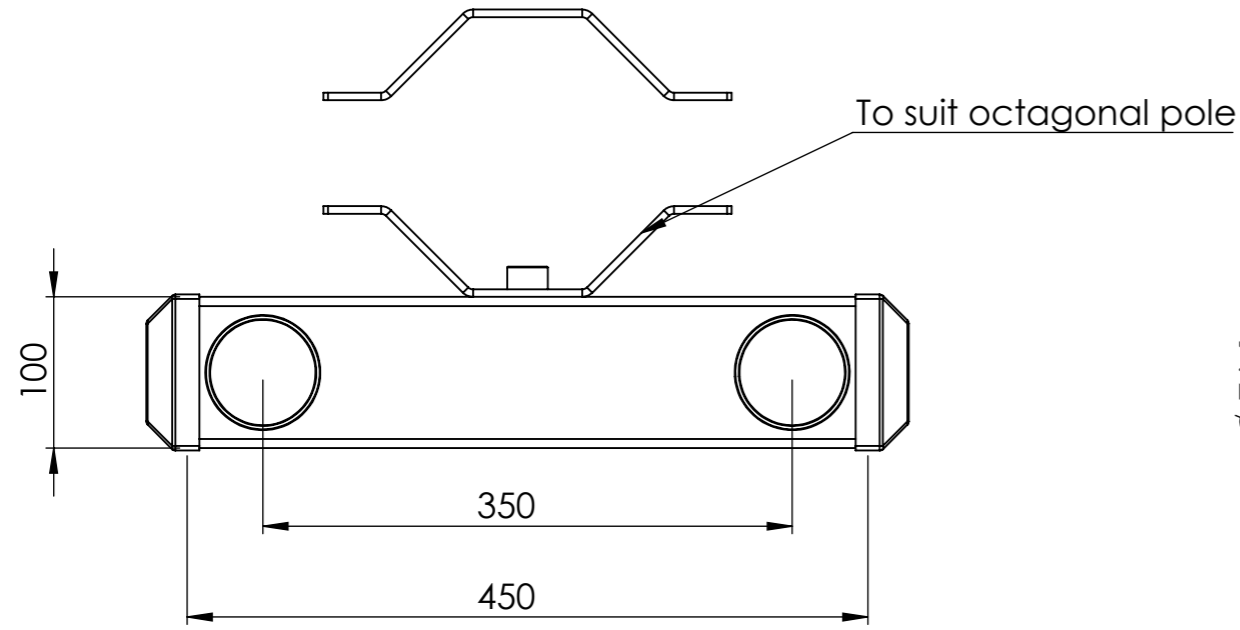

UNLESS OTHERWISE SPECIFIED: DIMENSIONS ARE IN MILLIMETERS	PROPRIETARY AND CONFIDENTIAL THE INFORMATION CONTAINED IN THIS DRAWING IS THE SOLE PROPERTY OF SEE SECURITY PTY LTD. ANY REPRODUCTION IN PART OR AS A WHOLE WITHOUT THE WRITTEN PERMISSION OF SEE SECURITY PTY LTD IS PROHIBITED.	DEBUR AND BREAK SHARP EDGES	DO NOT SCALE DRAWING	REVISION
FINISH:			 SEE SECURITY SECURITY & EQUIPMENT ENCLOSURES	
NAME	SIGNATURE	DATE		
DRAWN	ADC	14/10/2016	DWG NO.	A3
MATERIAL:	Weight		SB00211A06	
Steel galvanised	7.5kg		SCALE:1:5	SHEET 5 OF 84

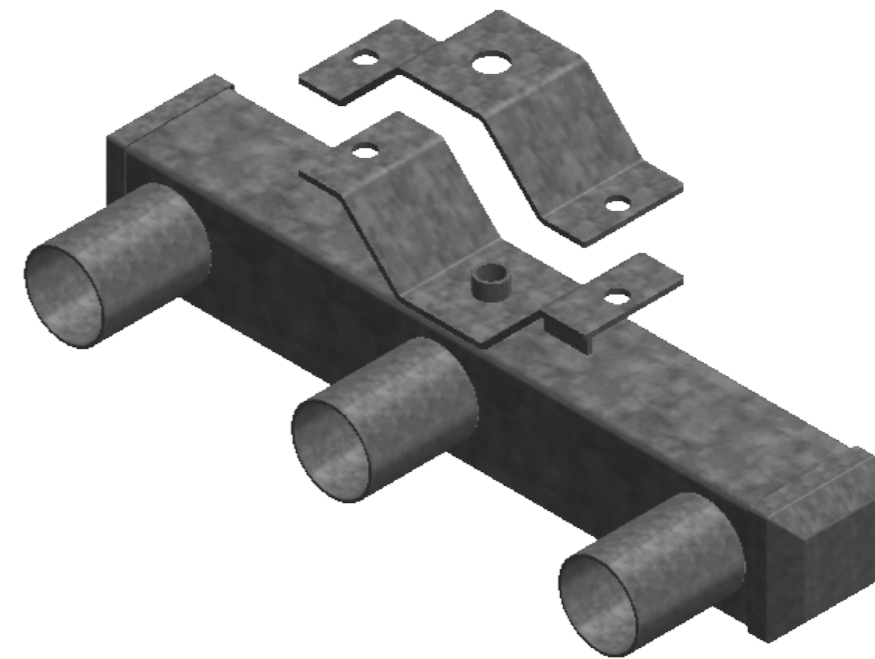
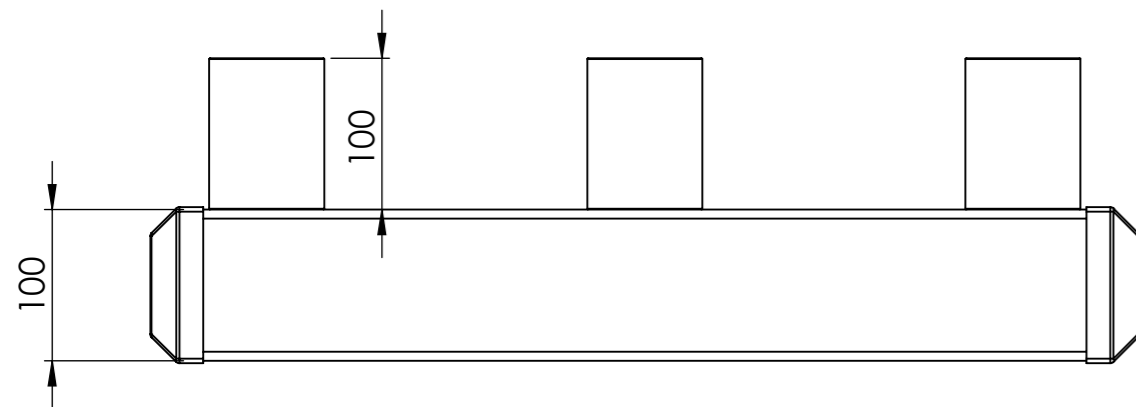
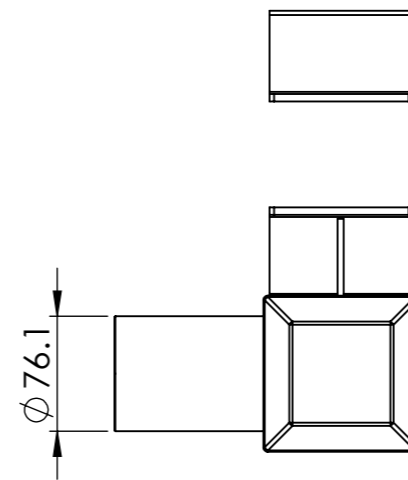
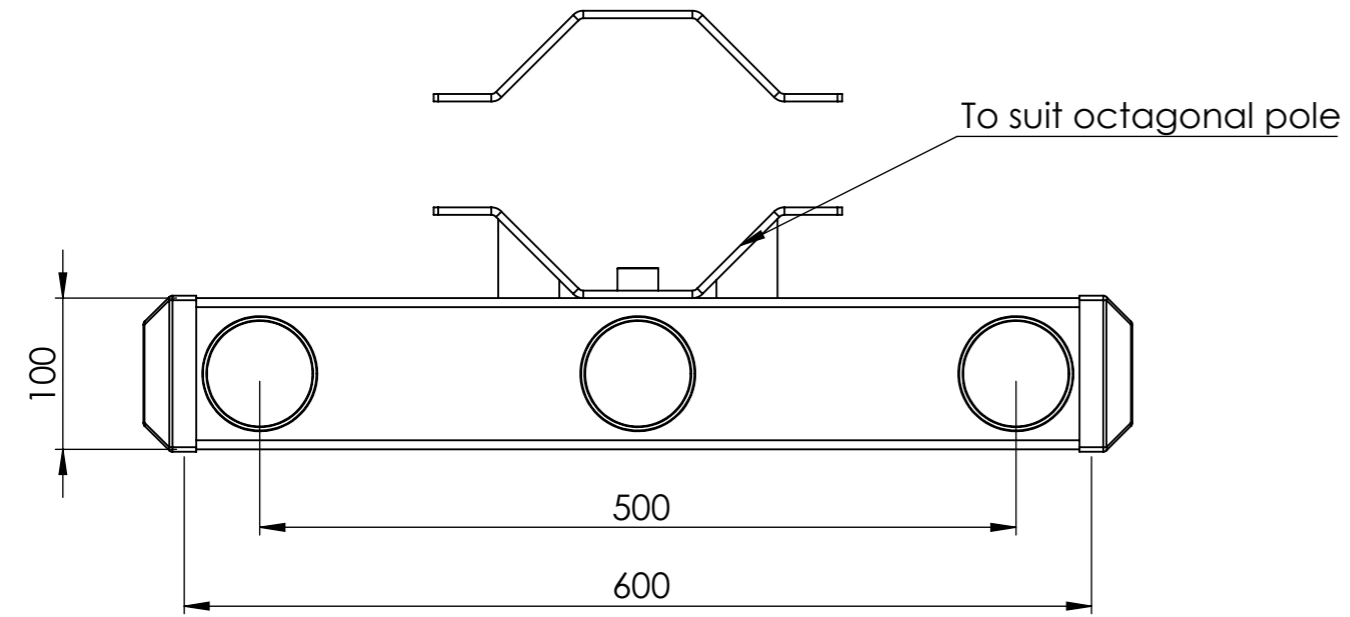

UNLESS OTHERWISE SPECIFIED: DIMENSIONS ARE IN MILLIMETERS	PROPRIETARY AND CONFIDENTIAL THE INFORMATION CONTAINED IN THIS DRAWING IS THE SOLE PROPERTY OF SEE SECURITY PTY LTD. ANY REPRODUCTION IN PART OR AS A WHOLE WITHOUT THE WRITTEN PERMISSION OF SEE SECURITY PTY LTD IS PROHIBITED.	DEBUR AND BREAK SHARP EDGES	DO NOT SCALE DRAWING	REVISION
FINISH:			 SEE SECURITY SECURITY & EQUIPMENT ENCLOSURES	
NAME	SIGNATURE	DATE		
DRAWN	ADC	14/10/2016	DWG NO.	A3
MATERIAL:	Weight		SB00211A07	
Steel galvanised	9.5kg		SCALE:1:5	SHEET 6 OF 84

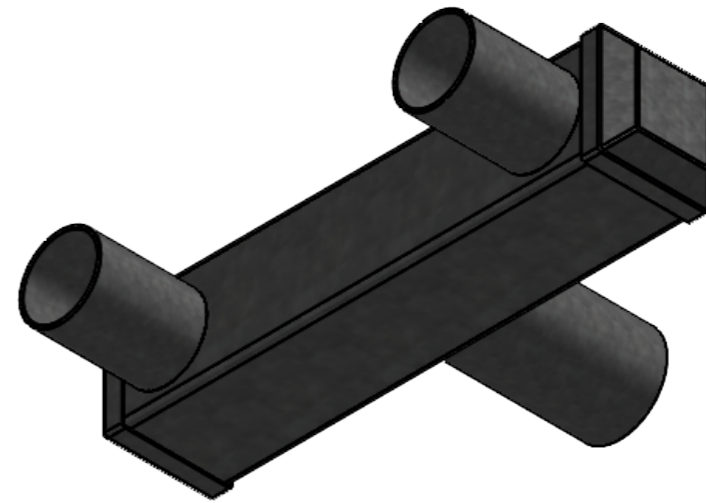
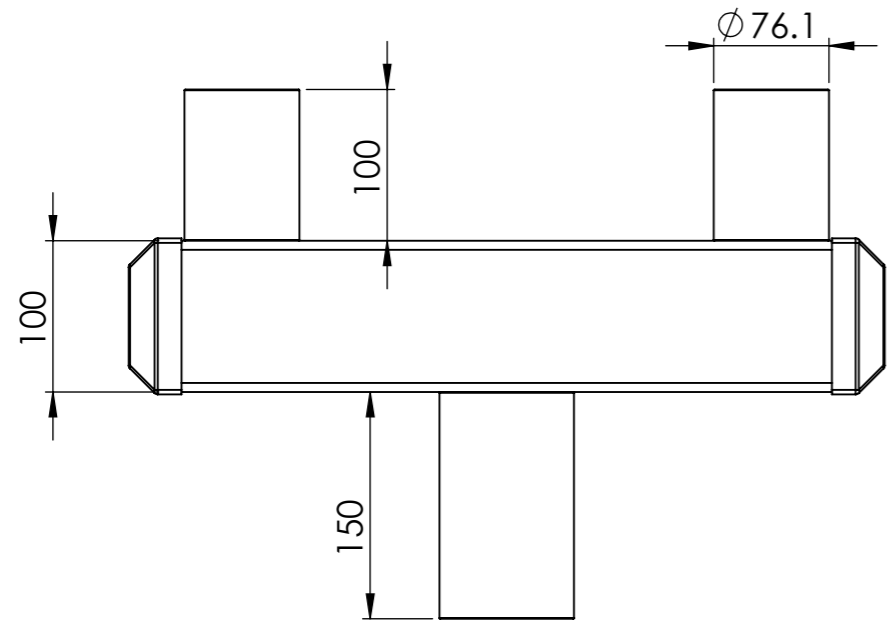
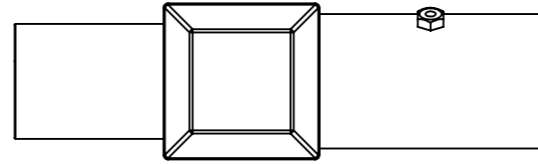
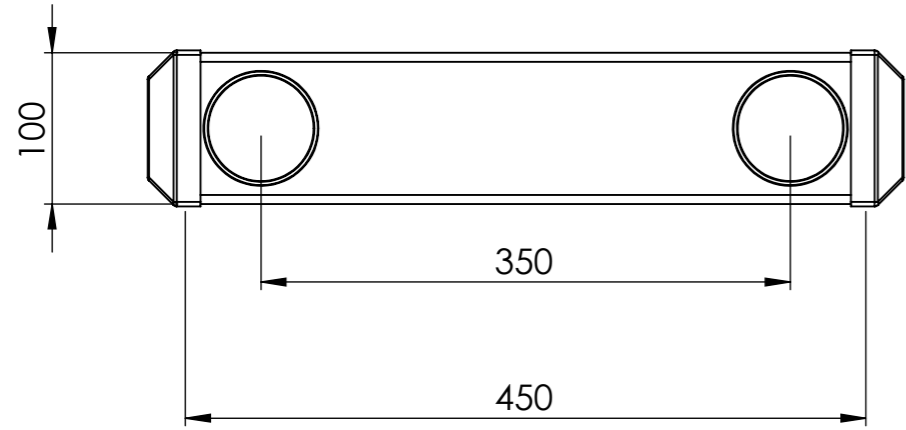

UNLESS OTHERWISE SPECIFIED: DIMENSIONS ARE IN MILLIMETERS	PROPRIETARY AND CONFIDENTIAL THE INFORMATION CONTAINED IN THIS DRAWING IS THE SOLE PROPERTY OF SEE SECURITY PTY LTD. ANY REPRODUCTION IN PART OR AS A WHOLE WITHOUT THE WRITTEN PERMISSION OF SEE SECURITY PTY LTD IS PROHIBITED.	DEBUR AND BREAK SHARP EDGES	DO NOT SCALE DRAWING	REVISION
FINISH:				
NAME	SIGNATURE	DATE		
DRAWN	ADC	14/10/2016	DWG NO.	A3
MATERIAL:	Weight		SB00211A08	
Steel galvanised	6.5kg		SCALE:1:5	SHEET 7 OF 84

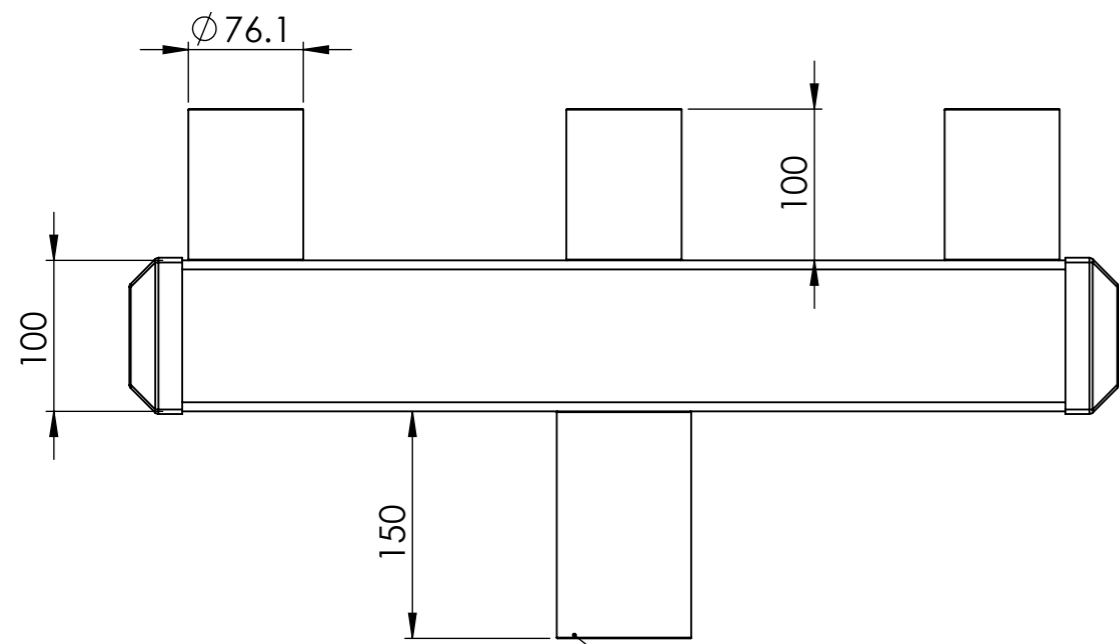
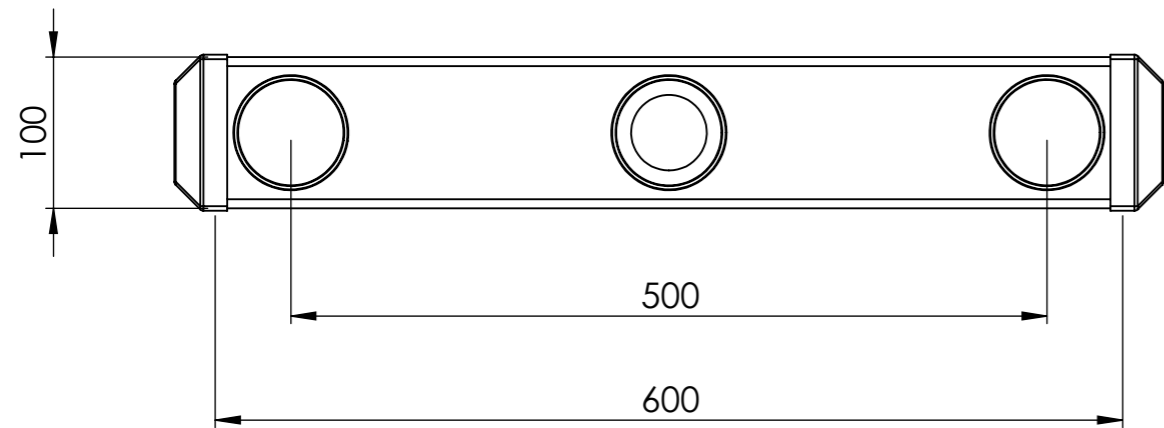

To suit 76.1 spigot

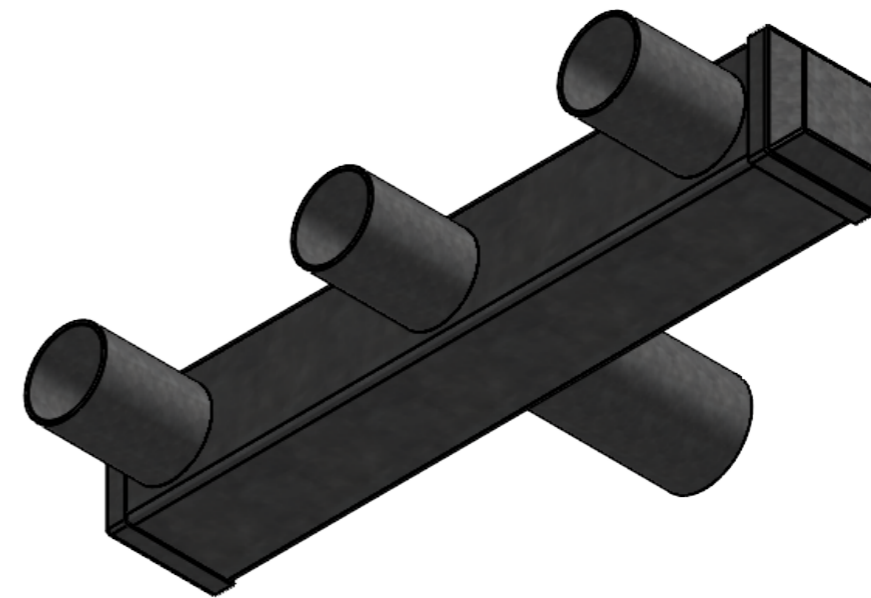
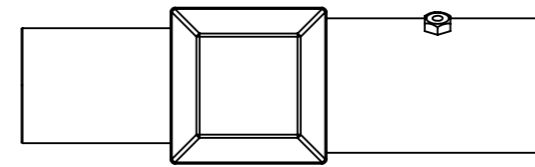

UNLESS OTHERWISE SPECIFIED: DIMENSIONS ARE IN MILLIMETERS	PROPRIETARY AND CONFIDENTIAL THE INFORMATION CONTAINED IN THIS DRAWING IS THE SOLE PROPERTY OF SEE SECURITY PTY LTD. ANY REPRODUCTION IN PART OR AS A WHOLE WITHOUT THE WRITTEN PERMISSION OF SEE SECURITY PTY LTD IS PROHIBITED.	DEBUR AND BREAK SHARP EDGES	DO NOT SCALE DRAWING	REVISION
FINISH:			 SEE SECURITY SECURITY & EQUIPMENT ENCLOSURES	
NAME	SIGNATURE	DATE		
DRAWN	ADC	14/10/2016	MATERIAL:	Weight
			Steel galvanised	8.5kg
			DWG NO.	A3
			SB00211A09	
			SCALE:1:5	SHEET 8 OF 84

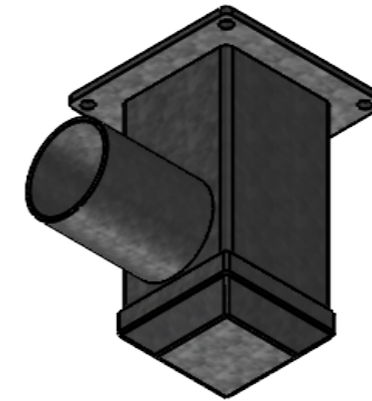
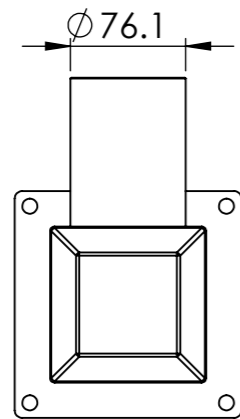
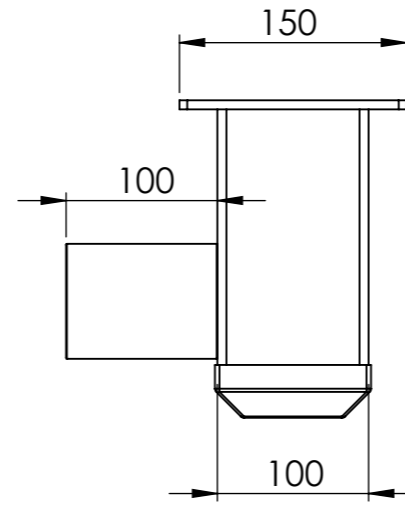
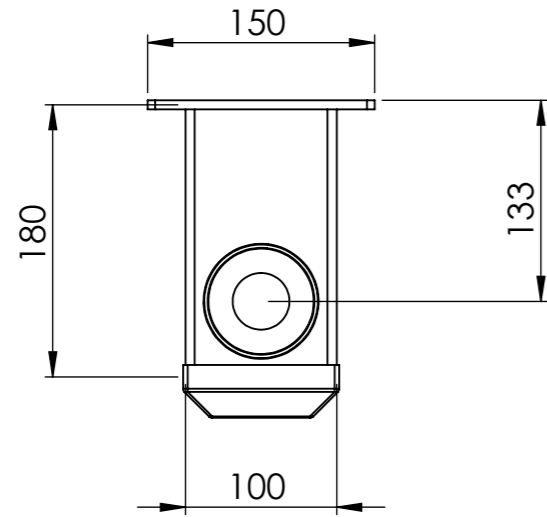

UNLESS OTHERWISE SPECIFIED: DIMENSIONS ARE IN MILLIMETERS	PROPRIETARY AND CONFIDENTIAL THE INFORMATION CONTAINED IN THIS DRAWING IS THE SOLE PROPERTY OF SEE SECURITY PTY LTD. ANY REPRODUCTION IN PART OR AS A WHOLE WITHOUT THE WRITTEN PERMISSION OF SEE SECURITY PTY LTD IS PROHIBITED.	DEBUR AND BREAK SHARP EDGES	DO NOT SCALE DRAWING	REVISION
FINISH:				
NAME	SIGNATURE	DATE		
DRAWN	ADC	14/10/2016	DWG NO.	A3
MATERIAL:	Weight		SB00211A11	
Steel galvanised	3kg		SCALE:1:5	SHEET 9 OF 84

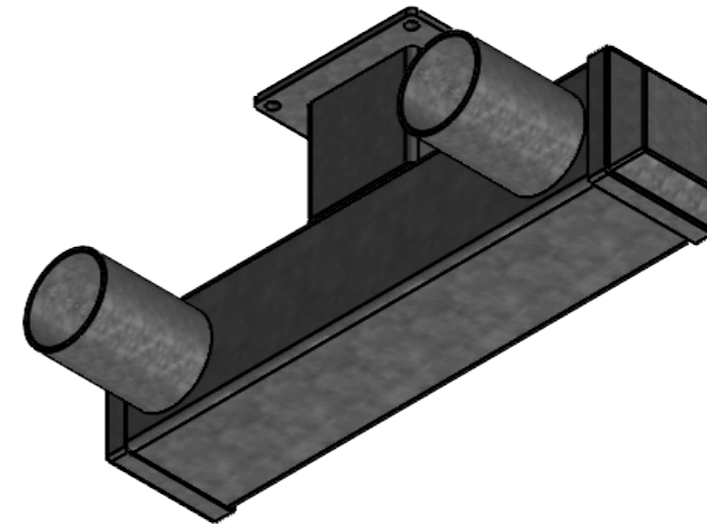
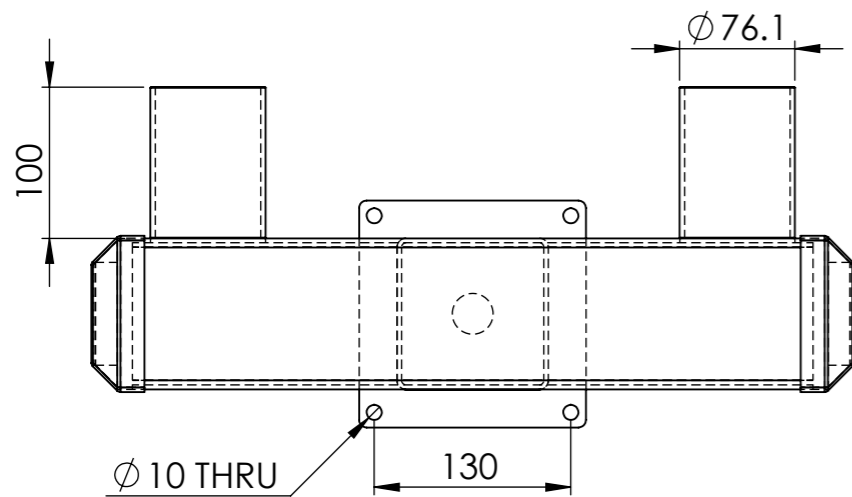
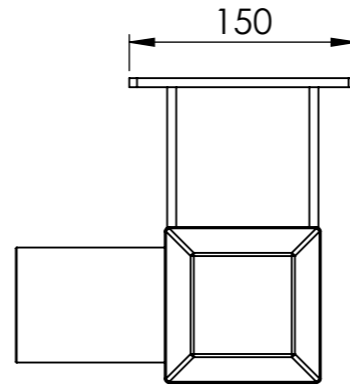
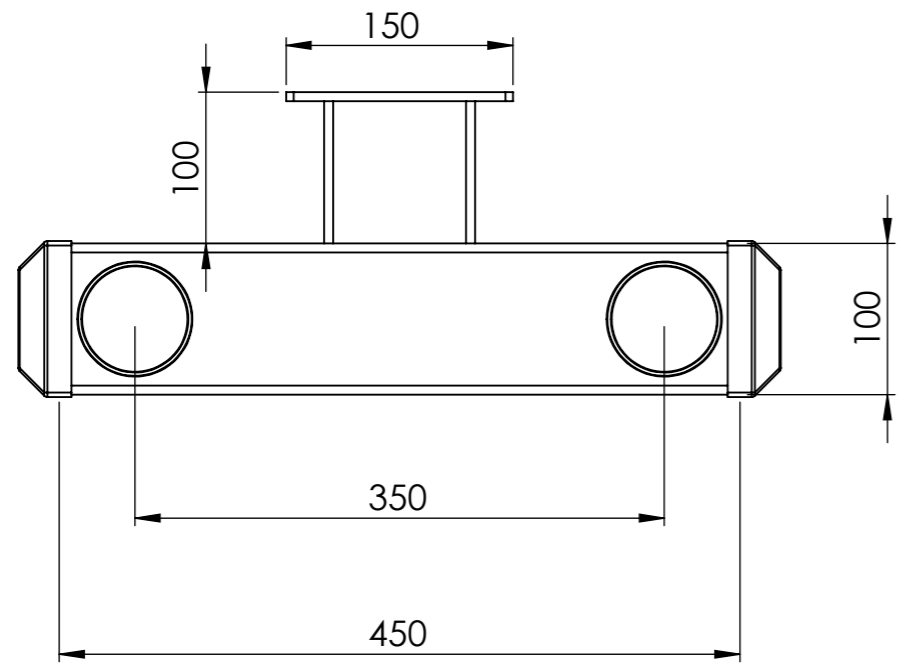

UNLESS OTHERWISE SPECIFIED: DIMENSIONS ARE IN MILLIMETERS		PROPRIETARY AND CONFIDENTIAL THE INFORMATION CONTAINED IN THIS DRAWING IS THE SOLE PROPERTY OF SEE SECURITY PTY LTD. ANY REPRODUCTION IN PART OR AS A WHOLE WITHOUT THE WRITTEN PERMISSION OF SEE SECURITY PTY LTD IS PROHIBITED.		DEBUR AND BREAK SHARP EDGES		DO NOT SCALE DRAWING		REVISION	
FINISH:		NAME		SIGNATURE		DATE		 SEE SECURITY SECURITY & EQUIPMENT ENCLOSURES	
DRAWN		ADC		14/10/2016		DWG NO.			
MATERIAL: Steel galvanised				Weight 7kg		SB00211A12			
SCALE:1:5						SHEET 10 OF 84			

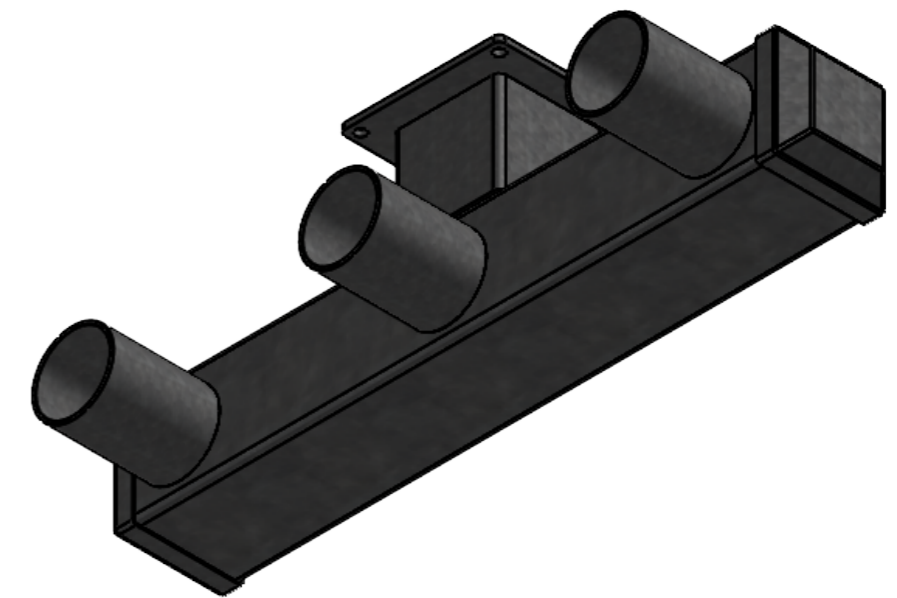
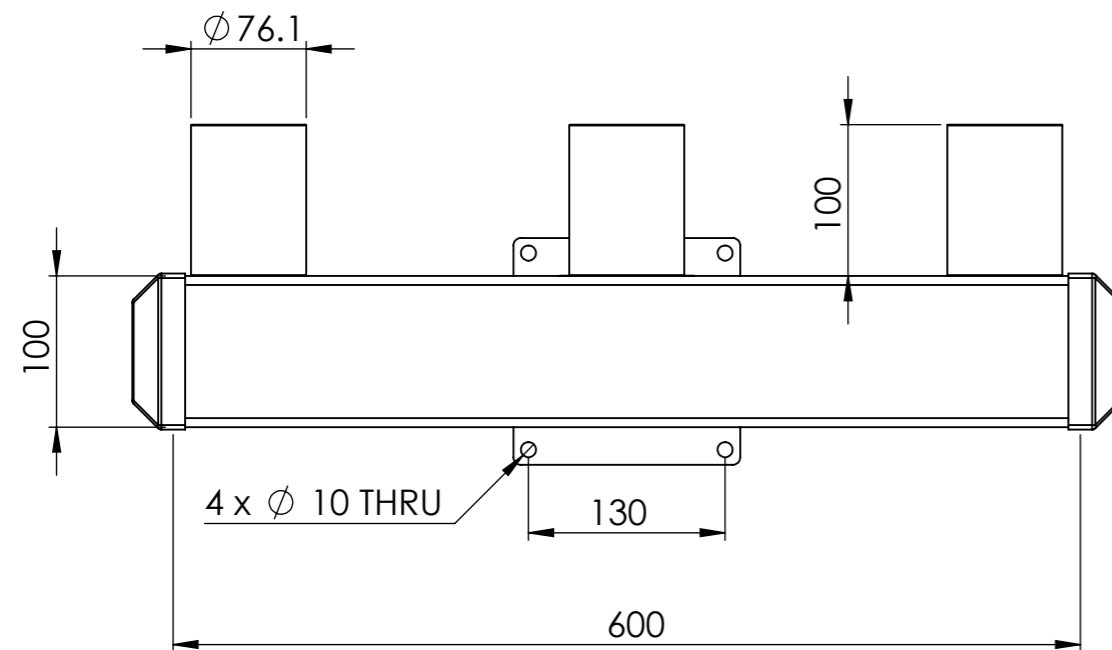
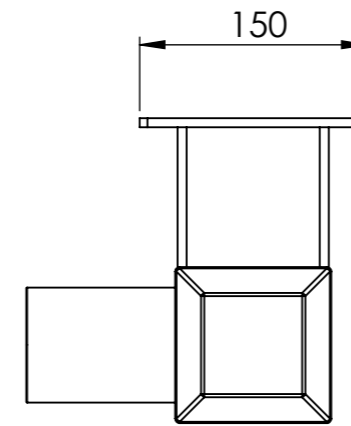
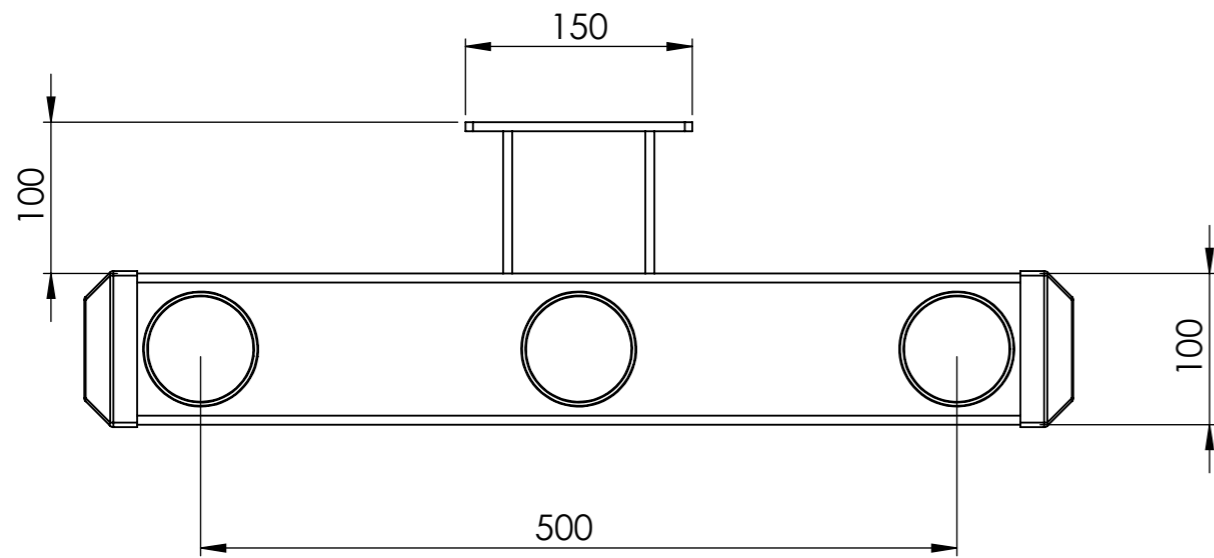

UNLESS OTHERWISE SPECIFIED: DIMENSIONS ARE IN MILLIMETERS	PROPRIETARY AND CONFIDENTIAL THE INFORMATION CONTAINED IN THIS DRAWING IS THE SOLE PROPERTY OF SEE SECURITY PTY LTD. ANY REPRODUCTION IN PART OR AS A WHOLE WITHOUT THE WRITTEN PERMISSION OF SEE SECURITY PTY LTD IS PROHIBITED.	DEBUR AND BREAK SHARP EDGES	DO NOT SCALE DRAWING	REVISION
FINISH:			 SEE SECURITY SECURITY & EQUIPMENT ENCLOSURES	
NAME	SIGNATURE	DATE		
DRAWN	ADC	14/10/2016	DWG NO.	A3
MATERIAL:	Weight		SB00211A13	
Steel galvanised	9kg		SCALE:1:5	SHEET 11 OF 84

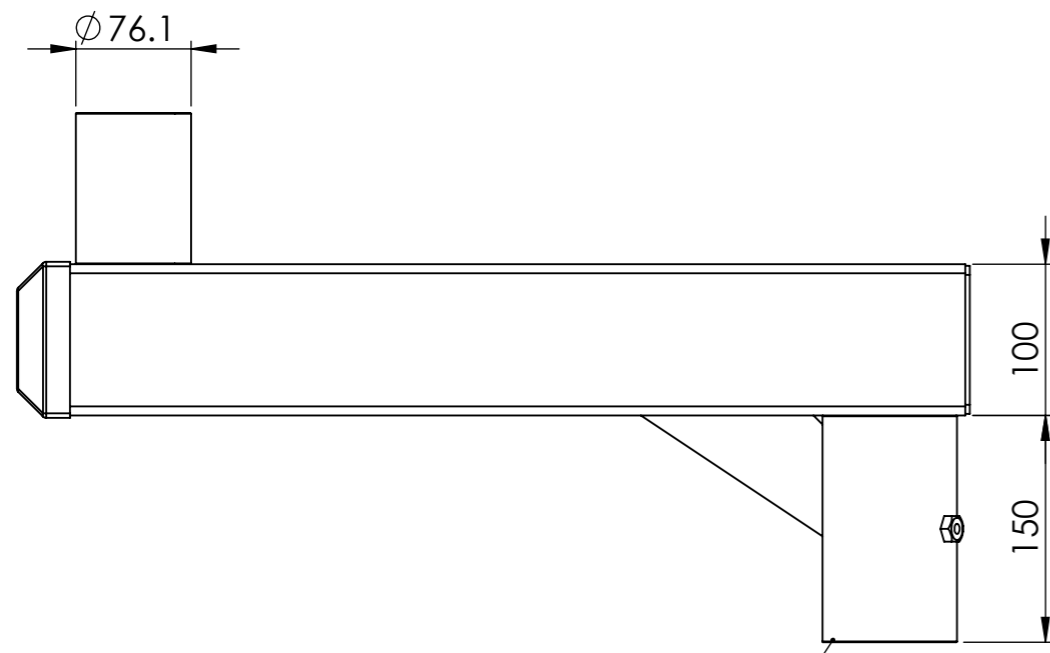
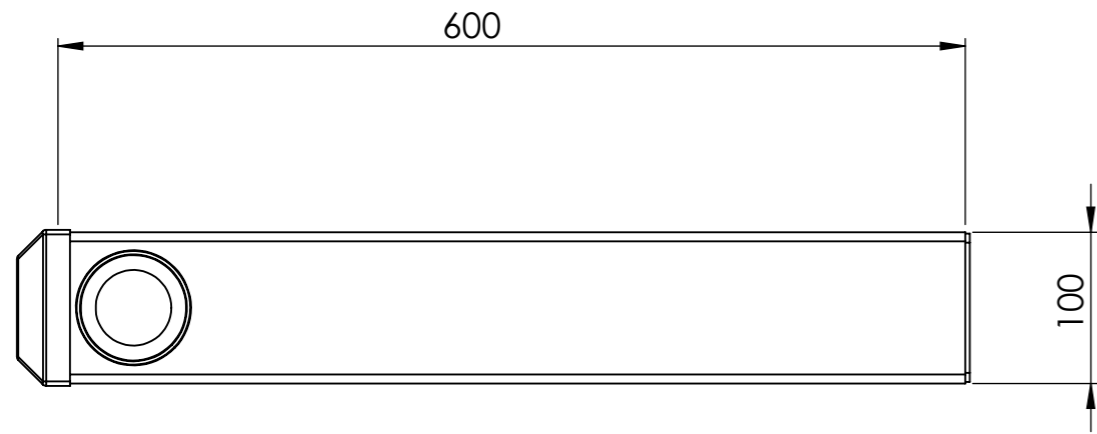

to suit 76.1 spigot

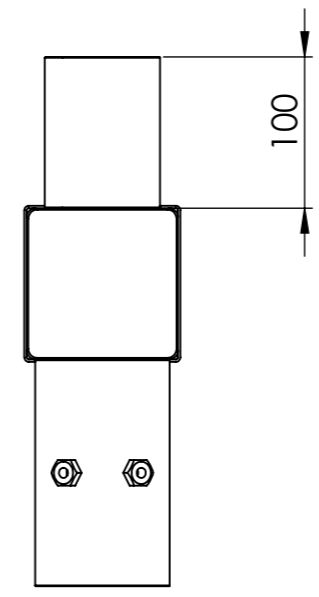

UNLESS OTHERWISE SPECIFIED: DIMENSIONS ARE IN MILLIMETERS	PROPRIETARY AND CONFIDENTIAL THE INFORMATION CONTAINED IN THIS DRAWING IS THE SOLE PROPERTY OF SEE SECURITY PTY LTD. ANY REPRODUCTION IN PART OR AS A WHOLE WITHOUT THE WRITTEN PERMISSION OF SEE SECURITY PTY LTD IS PROHIBITED.	DEBUR AND BREAK SHARP EDGES	DO NOT SCALE DRAWING	REVISION
FINISH:			 SEE SECURITY SECURITY & EQUIPMENT ENCLOSURES	
NAME	SIGNATURE	DATE		
DRAWN	ADC	14/10/2016	DWG NO.	A3
MATERIAL:	Weight		SB00211A14	
Steel galvanised	7.5kg		SCALE:1:5	SHEET 12 OF 84

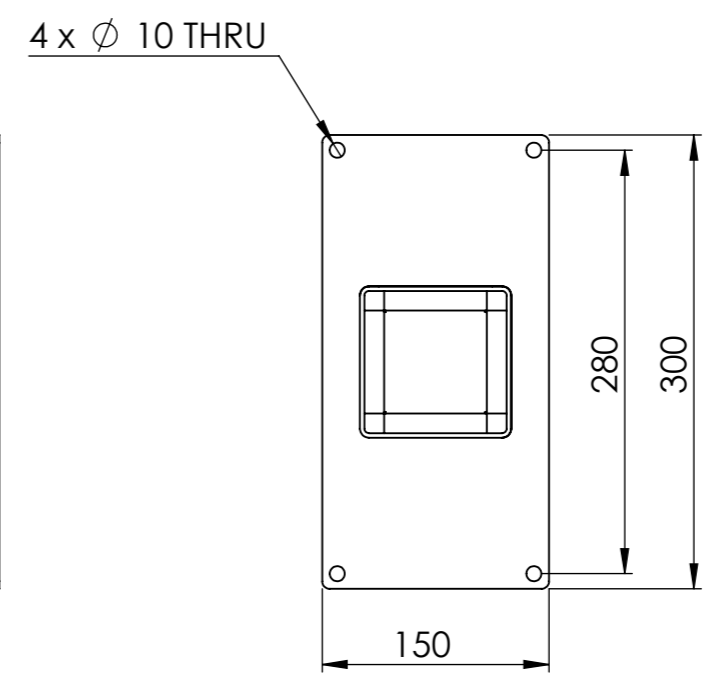
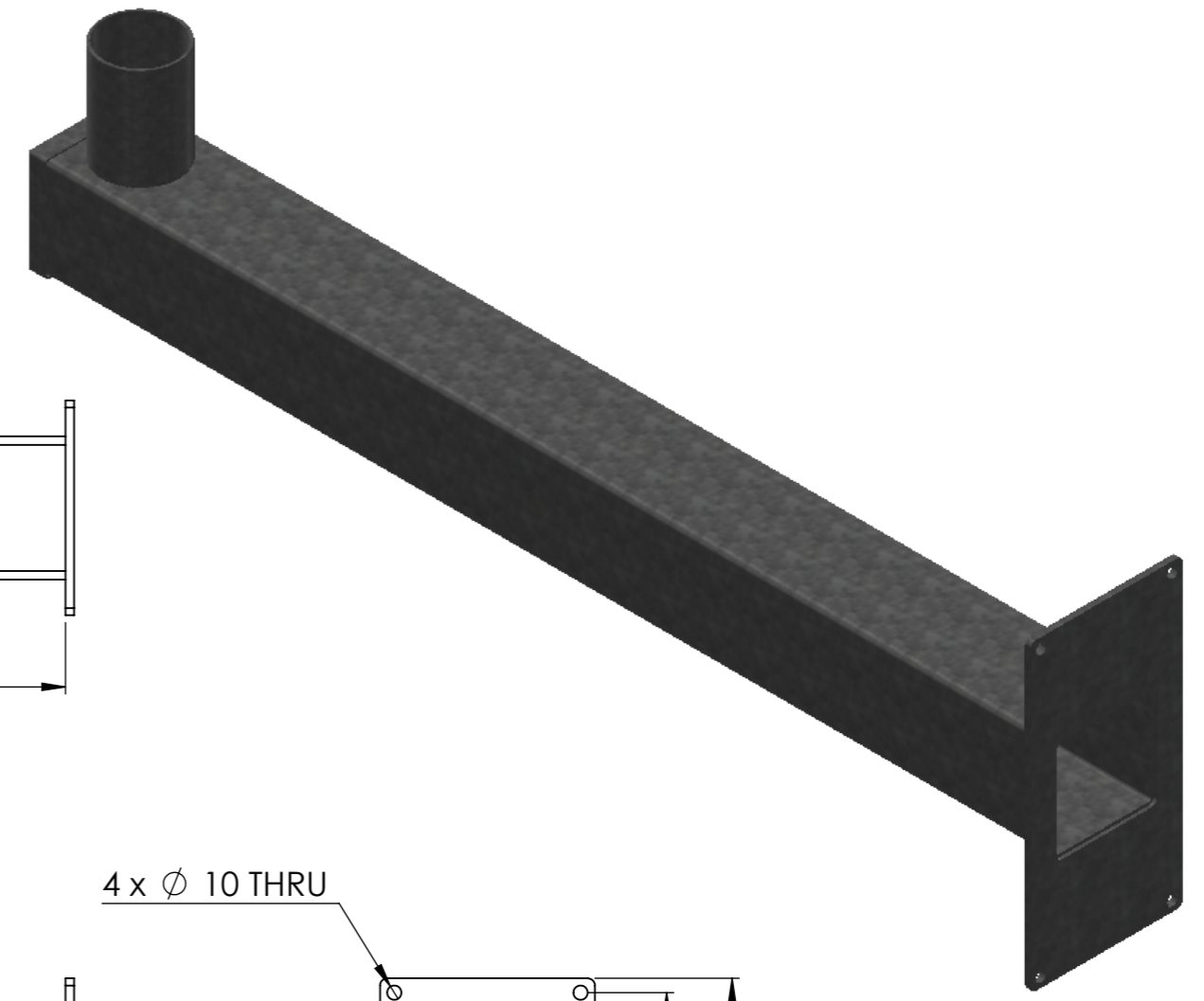
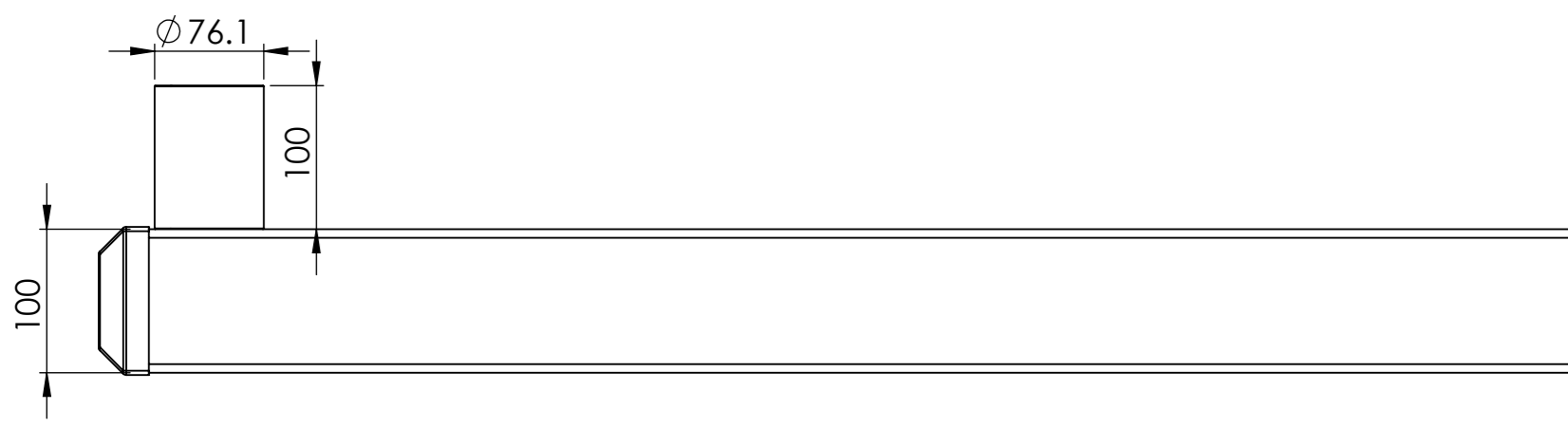
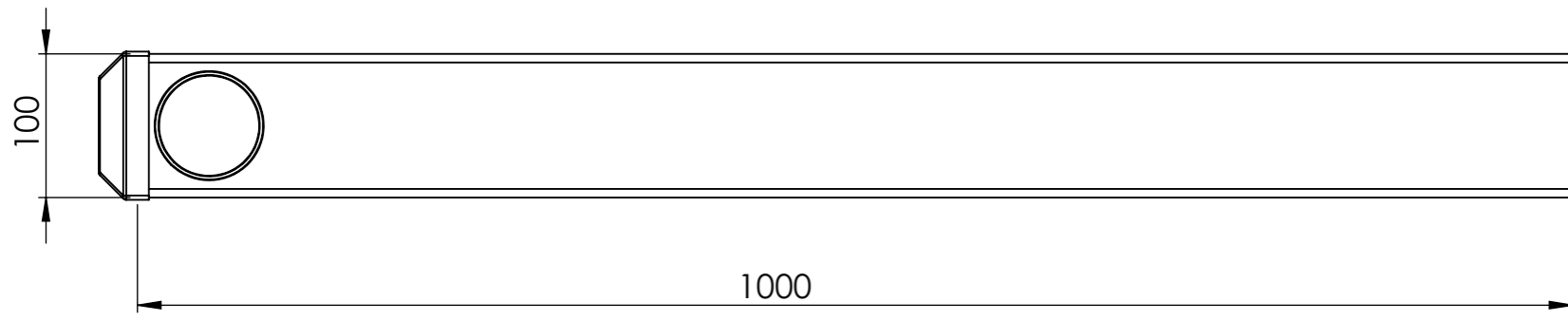

UNLESS OTHERWISE SPECIFIED: DIMENSIONS ARE IN MILLIMETERS	PROPRIETARY AND CONFIDENTIAL THE INFORMATION CONTAINED IN THIS DRAWING IS THE SOLE PROPERTY OF SEE SECURITY PTY LTD. ANY REPRODUCTION IN PART OR AS A WHOLE WITHOUT THE WRITTEN PERMISSION OF SEE SECURITY PTY LTD IS PROHIBITED.	DEBUR AND BREAK SHARP EDGES	DO NOT SCALE DRAWING	REVISION
FINISH:				
NAME	SIGNATURE	DATE		
DRAWN	ADC	14/10/2016	DWG NO.	SB00211A16
MATERIAL:	Steel galvanised	Weight	11kg	A3
		SCALE:1:10	SHEET 13 OF 84	

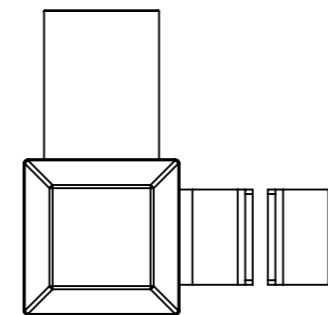
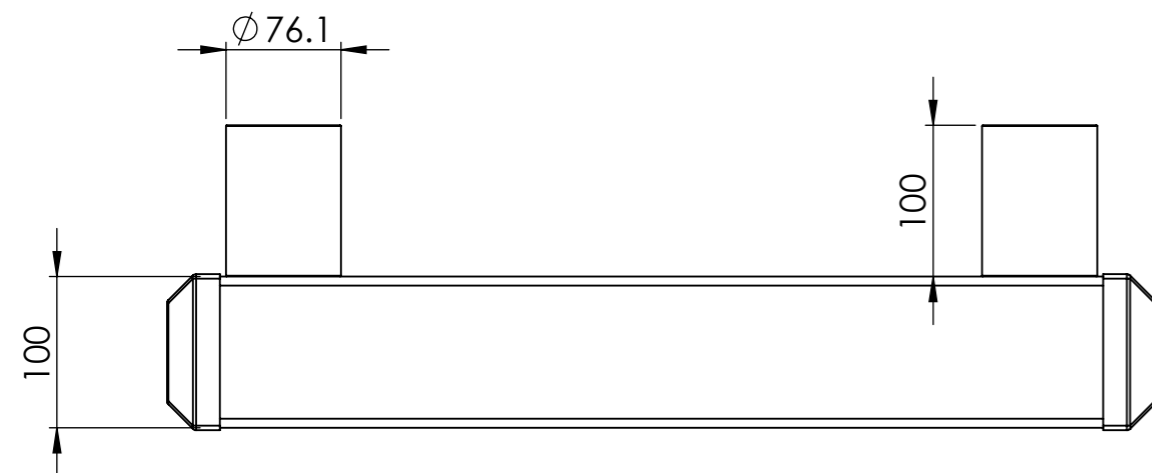
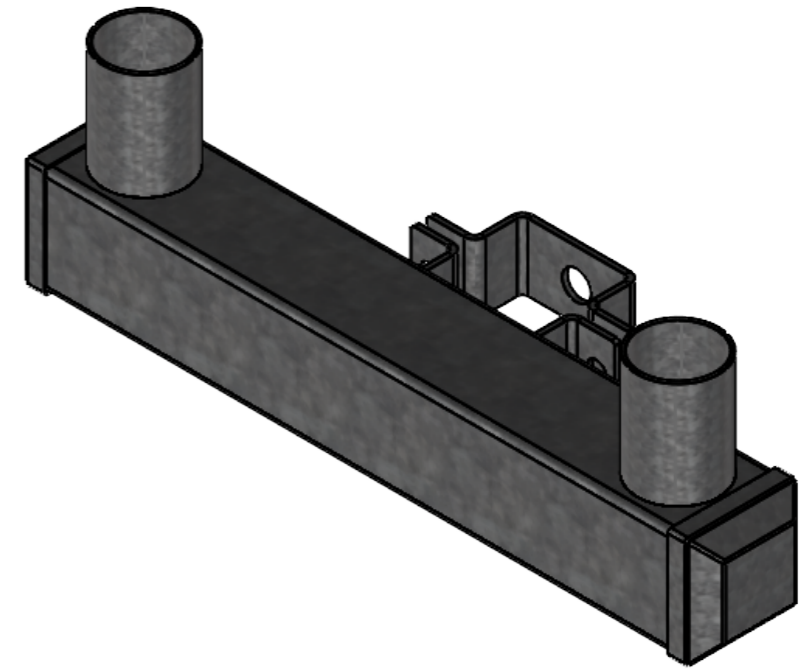
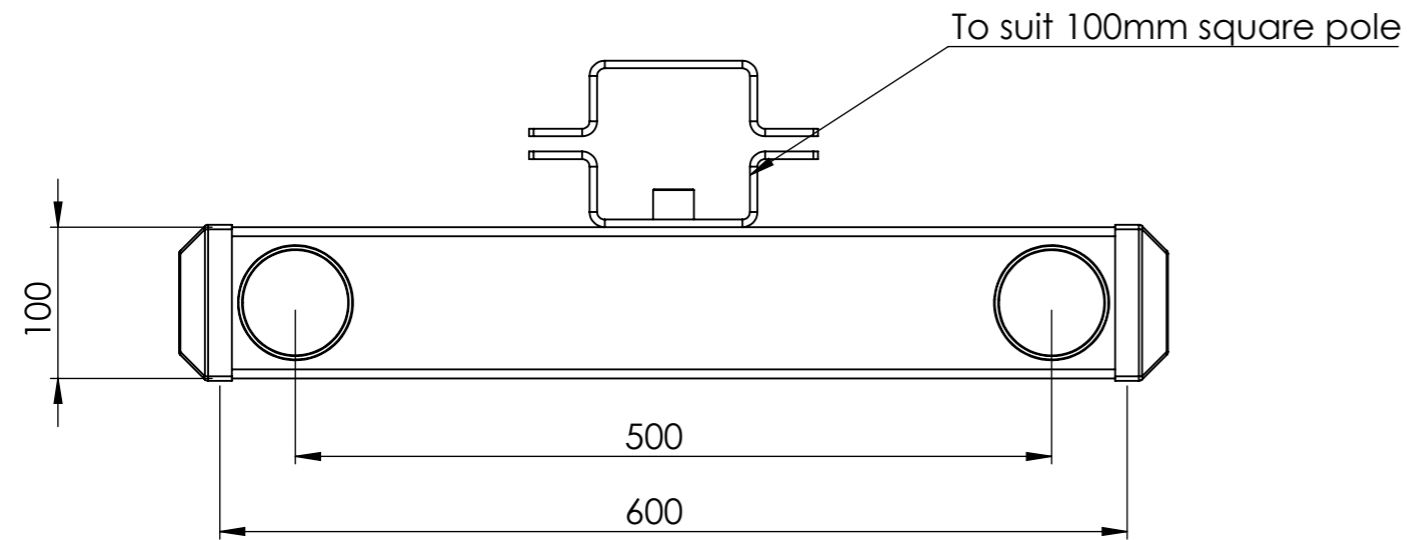

UNLESS OTHERWISE SPECIFIED: DIMENSIONS ARE IN MILLIMETERS	PROPRIETARY AND CONFIDENTIAL THE INFORMATION CONTAINED IN THIS DRAWING IS THE SOLE PROPERTY OF SEE SECURITY PTY LTD. ANY REPRODUCTION IN PART OR AS A WHOLE WITHOUT THE WRITTEN PERMISSION OF SEE SECURITY PTY LTD IS PROHIBITED.	DEBUR AND BREAK SHARP EDGES	DO NOT SCALE DRAWING	REVISION
FINISH:			 SEE SECURITY SECURITY & EQUIPMENT ENCLOSURES	
NAME	SIGNATURE	DATE		
DRAWN	ADC	14/10/2016	DWG NO.	A3
MATERIAL:	Weight		SB00211A21	
Steel galvanised	8kg		SCALE:1:5	SHEET 14 OF 84

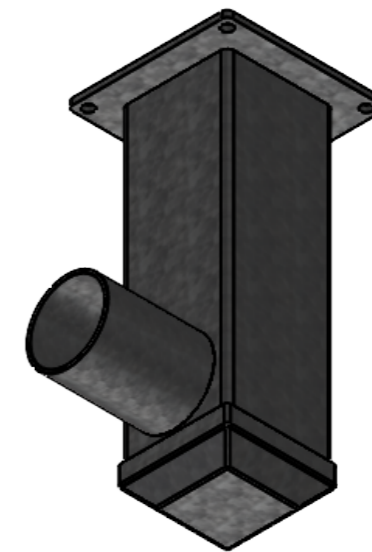
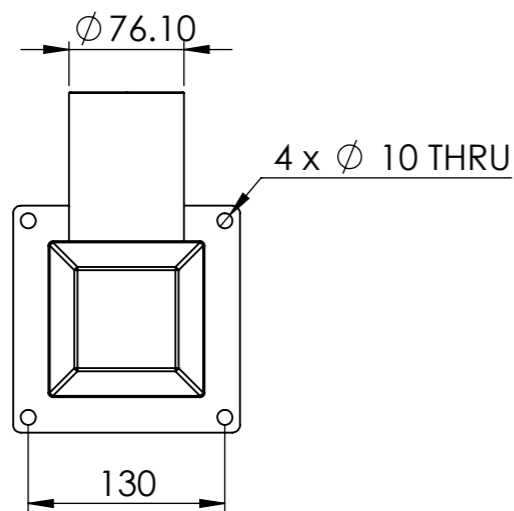
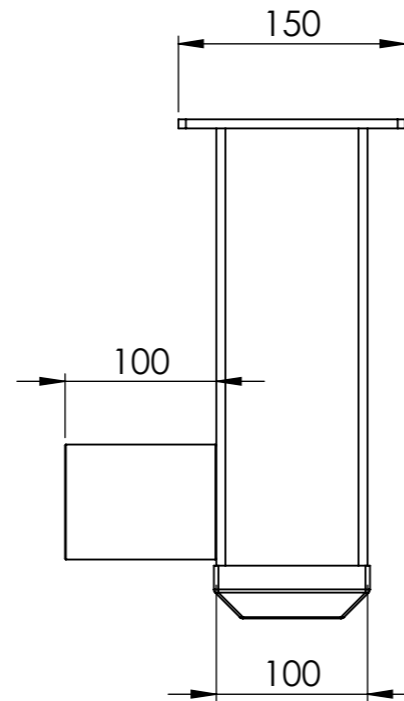
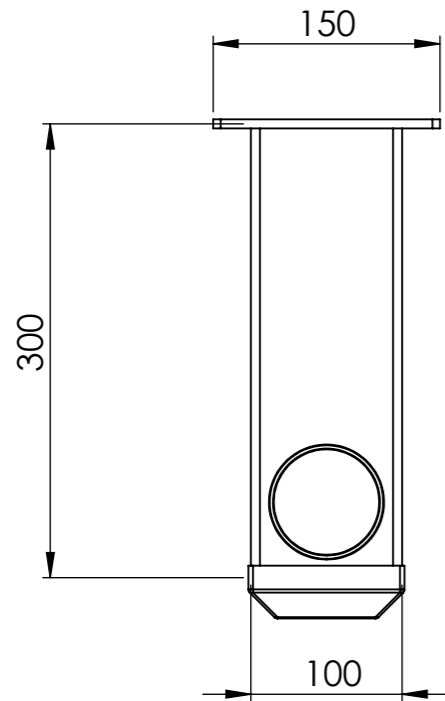

UNLESS OTHERWISE SPECIFIED: DIMENSIONS ARE IN MILLIMETERS	PROPRIETARY AND CONFIDENTIAL THE INFORMATION CONTAINED IN THIS DRAWING IS THE SOLE PROPERTY OF SEE SECURITY PTY LTD. ANY REPRODUCTION IN PART OR AS A WHOLE WITHOUT THE WRITTEN PERMISSION OF SEE SECURITY PTY LTD IS PROHIBITED.	DEBUR AND BREAK SHARP EDGES	DO NOT SCALE DRAWING	REVISION
FINISH:			 SEE SECURITY SECURITY & EQUIPMENT ENCLOSURES	
NAME	SIGNATURE	DATE		
DRAWN	ADC	14/10/2016	DWG NO.	SB00211A23
MATERIAL:	Steel galvanised	Weight	4kg	A3
		SCALE:1:5	SHEET 15 OF 84	

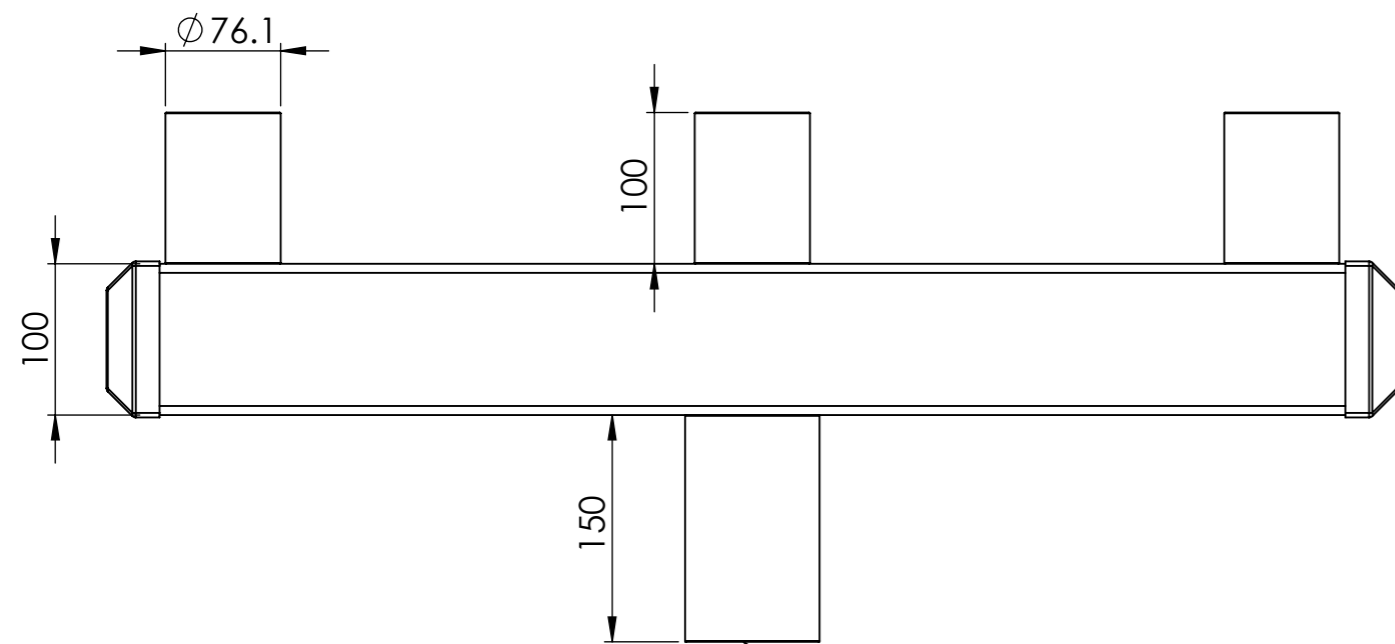
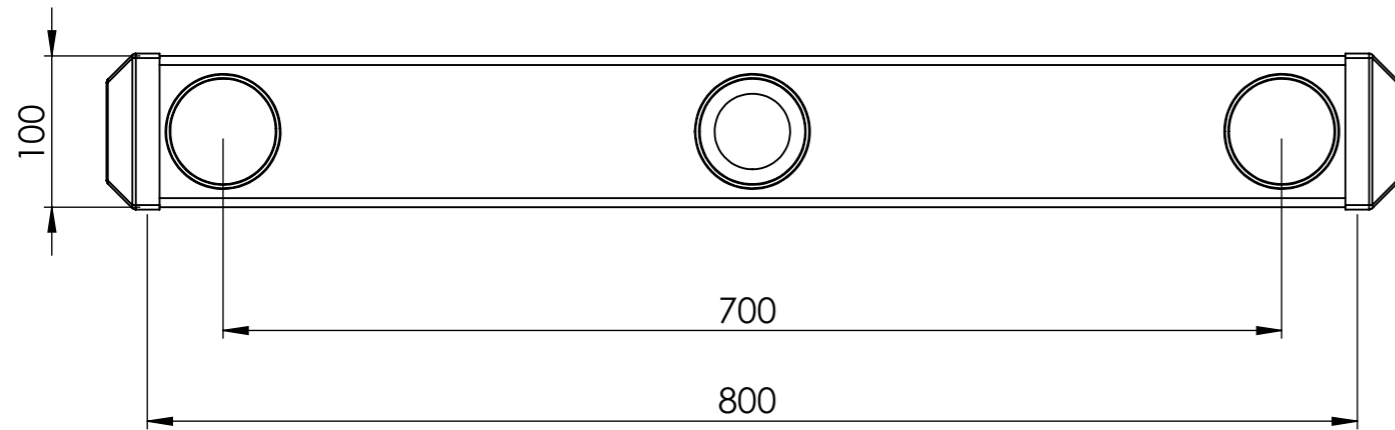

To suit 76.1 spigot

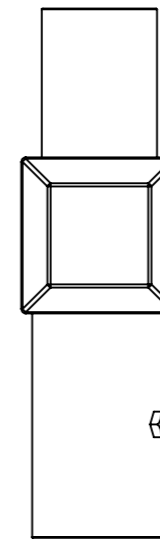
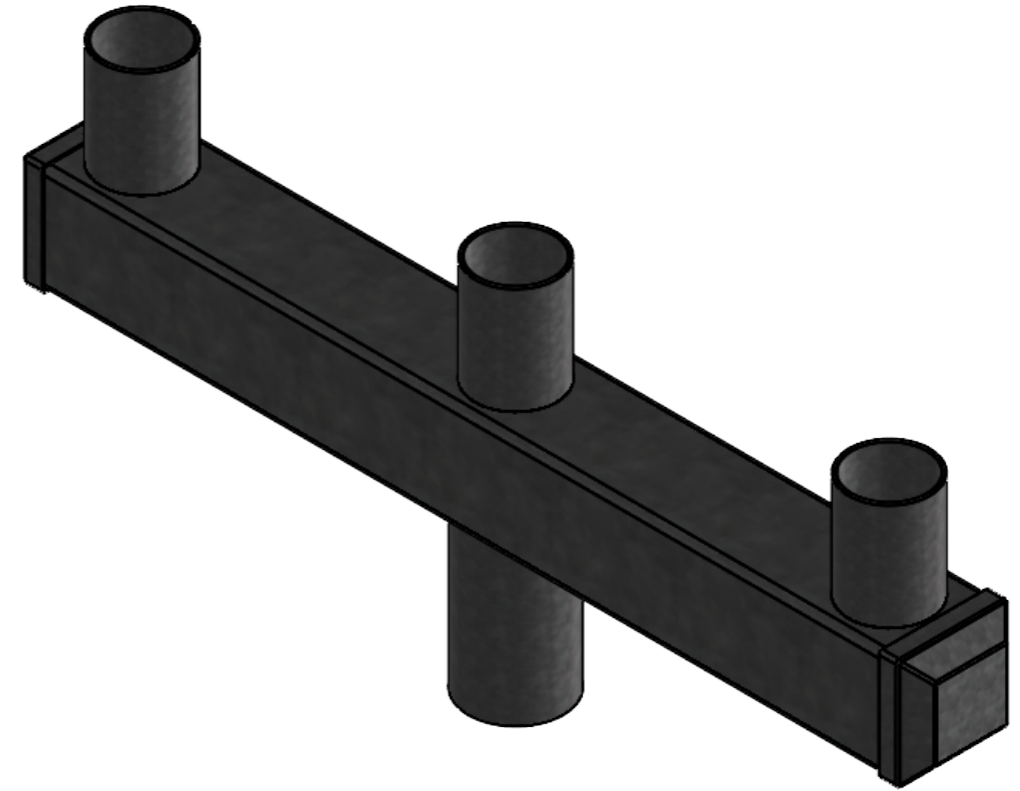

UNLESS OTHERWISE SPECIFIED: DIMENSIONS ARE IN MILLIMETERS		PROPRIETARY AND CONFIDENTIAL THE INFORMATION CONTAINED IN THIS DRAWING IS THE SOLE PROPERTY OF SEE SECURITY PTY LTD. ANY REPRODUCTION IN PART OR AS A WHOLE WITHOUT THE WRITTEN PERMISSION OF SEE SECURITY PTY LTD IS PROHIBITED.		DEBUR AND BREAK SHARP EDGES	DO NOT SCALE DRAWING	REVISION
FINISH:		NAME SIGNATURE DATE		 SEE SECURITY SECURITY & EQUIPMENT ENCLOSURES		
DRAWN ADC		14/10/2016				
MATERIAL: Steel galvanised		Weight 10kg		DWG NO. SB00211A24		A3
				SCALE:1:5	SHEET 16 OF 84	

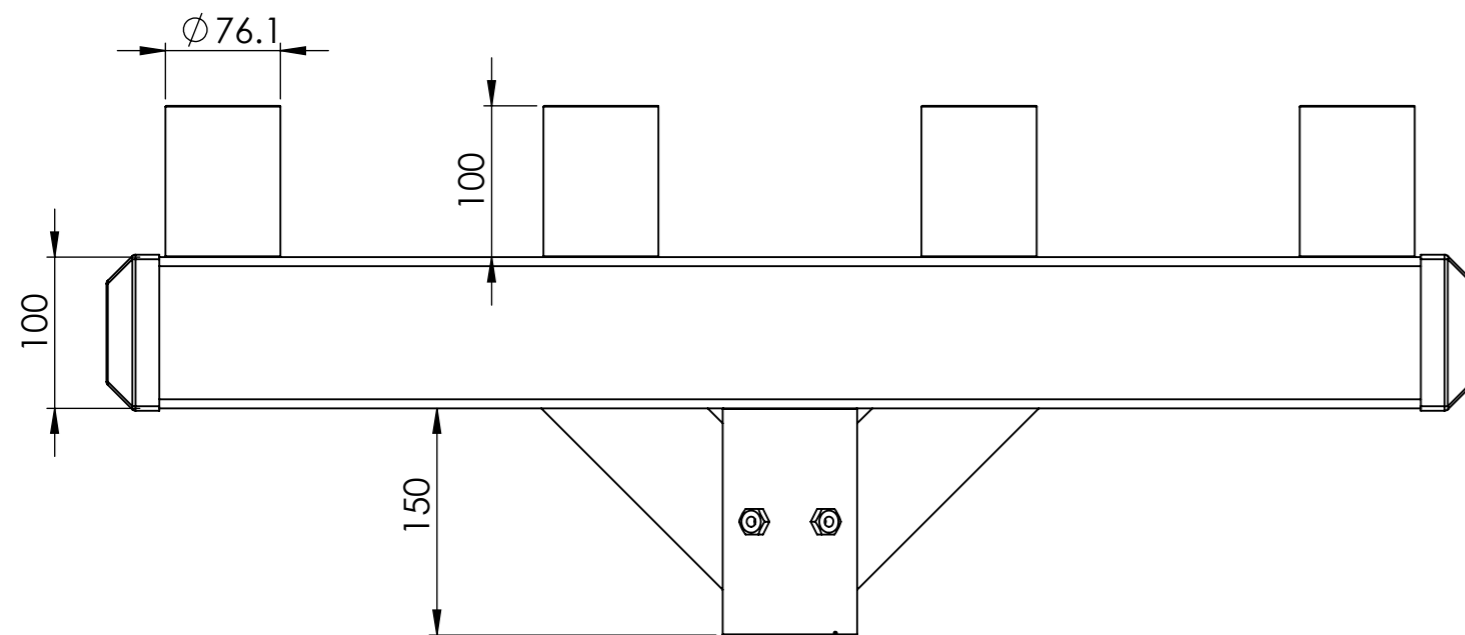
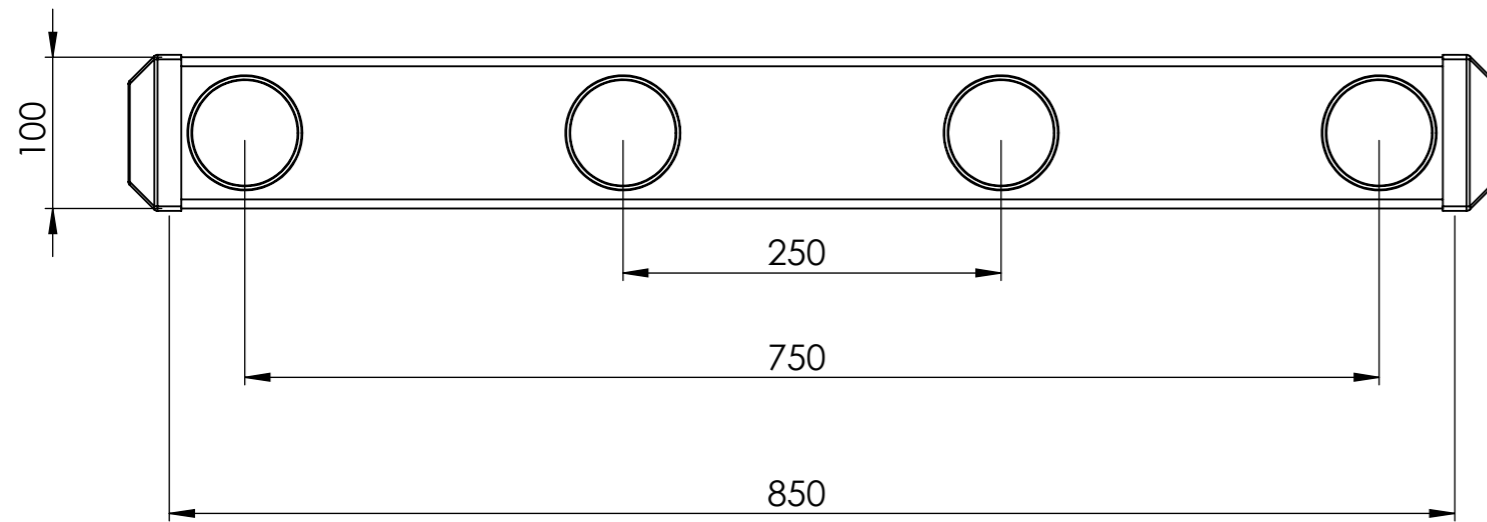

To suit 76.1 spigot

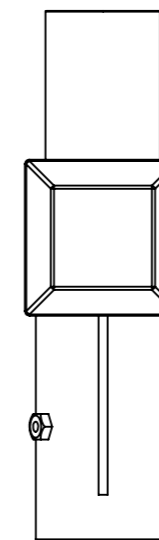
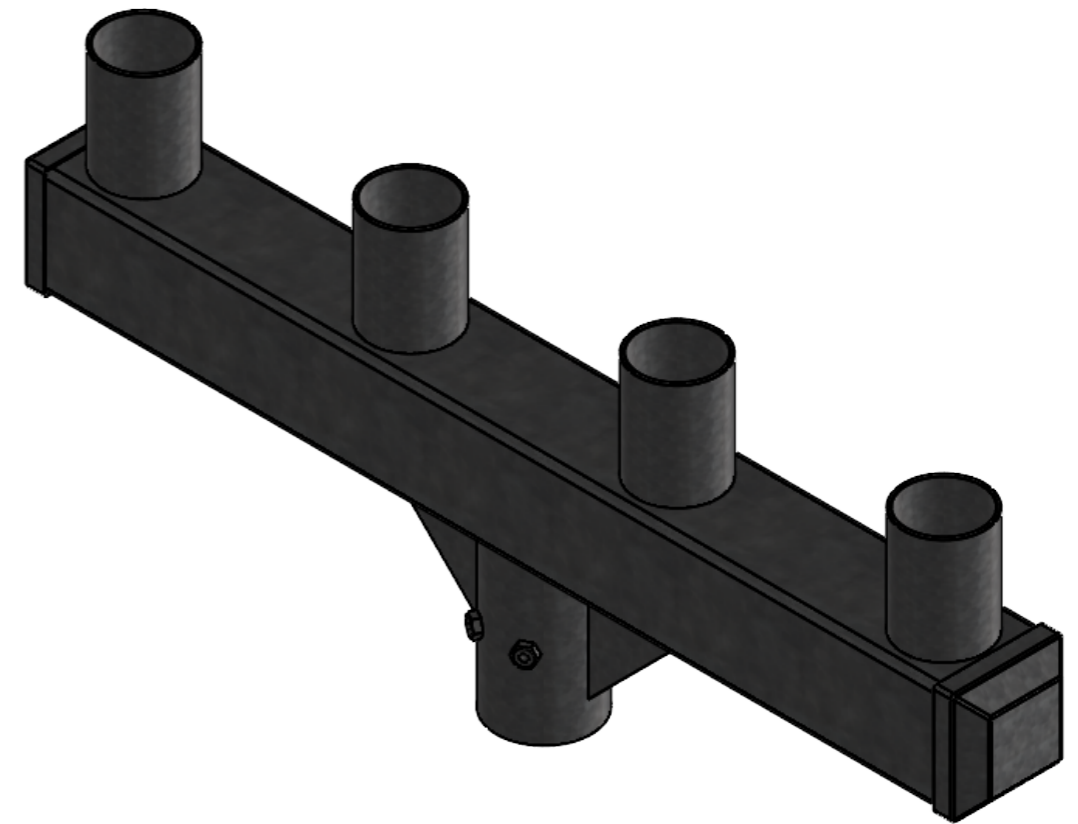

UNLESS OTHERWISE SPECIFIED: DIMENSIONS ARE IN MILLIMETERS	PROPRIETARY AND CONFIDENTIAL THE INFORMATION CONTAINED IN THIS DRAWING IS THE SOLE PROPERTY OF SEE SECURITY PTY LTD. ANY REPRODUCTION IN PART OR AS A WHOLE WITHOUT THE WRITTEN PERMISSION OF SEE SECURITY PTY LTD IS PROHIBITED.	DEBUR AND BREAK SHARP EDGES	DO NOT SCALE DRAWING	REVISION
FINISH:				
NAME	SIGNATURE	DATE		
DRAWN	ADC	14/10/2016		
MATERIAL:	Weight		DWG NO.	A3
Steel galvanised	12kg		SB00211A25	
			SCALE:1:5	SHEET 17 OF 84

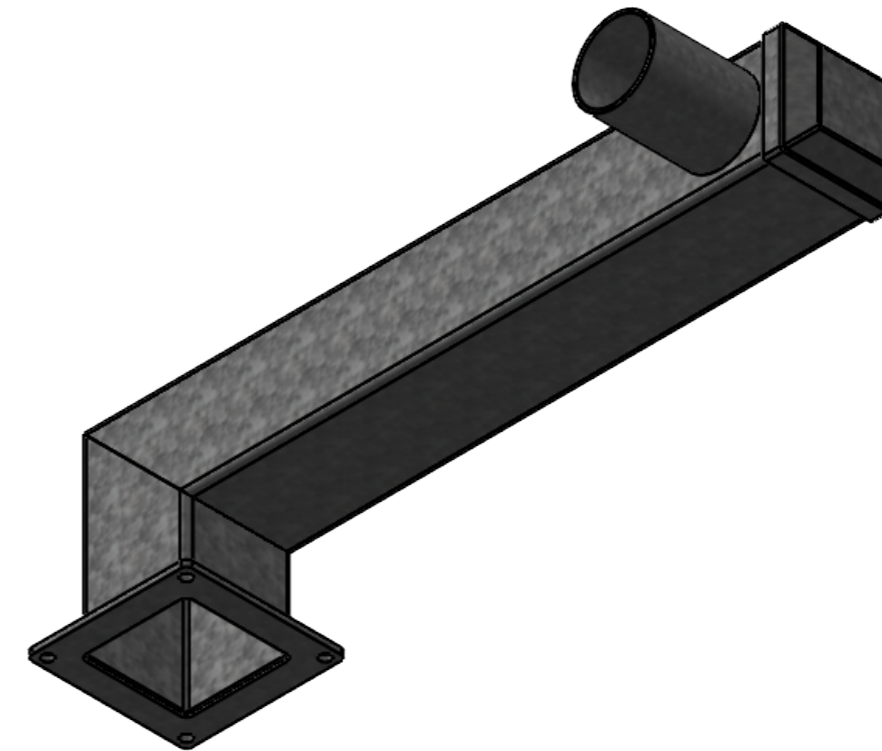
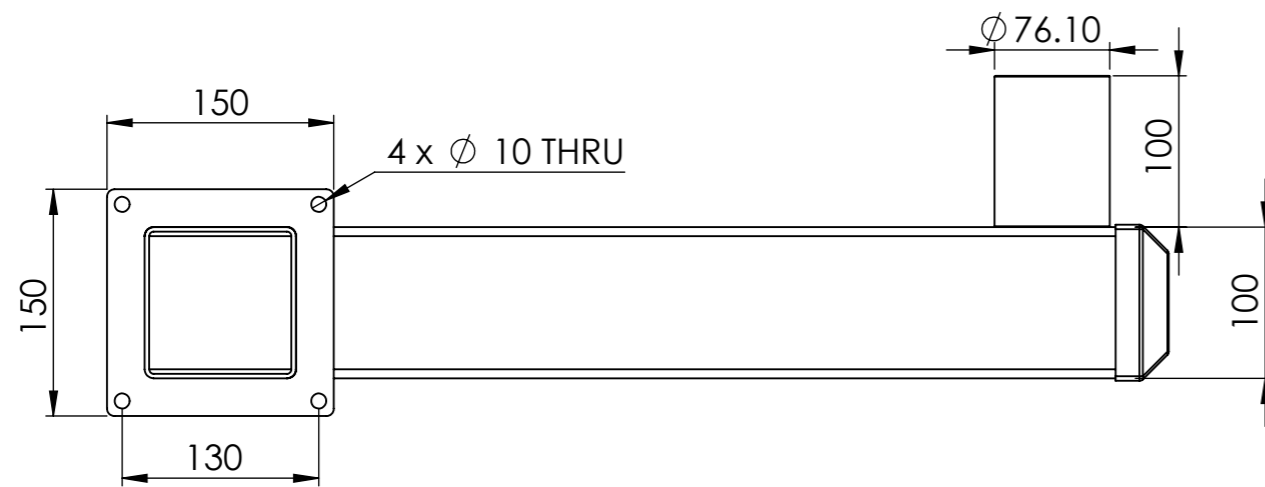
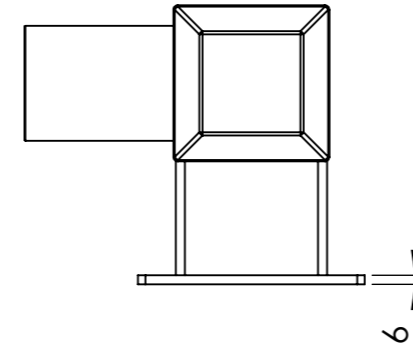
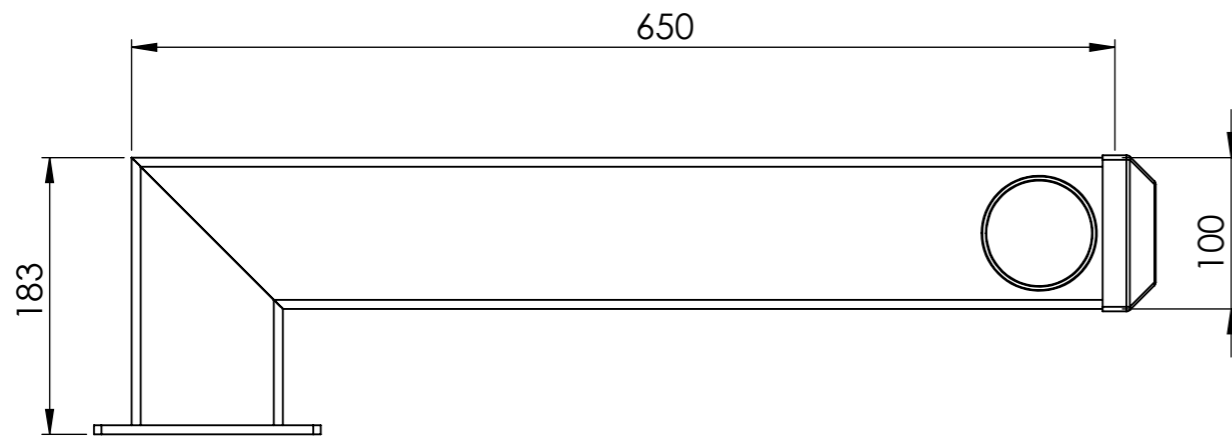

UNLESS OTHERWISE SPECIFIED: DIMENSIONS ARE IN MILLIMETERS	PROPRIETARY AND CONFIDENTIAL THE INFORMATION CONTAINED IN THIS DRAWING IS THE SOLE PROPERTY OF SEE SECURITY PTY LTD. ANY REPRODUCTION IN PART OR AS A WHOLE WITHOUT THE WRITTEN PERMISSION OF SEE SECURITY PTY LTD IS PROHIBITED.	DEBUR AND BREAK SHARP EDGES	DO NOT SCALE DRAWING	REVISION
FINISH:			 SEE SECURITY SECURITY & EQUIPMENT ENCLOSURES	
NAME	SIGNATURE	DATE		
DRAWN	ADC	14/10/2016	MATERIAL:	Weight
			Steel galvanised	8kg
			DWG NO.	A3
			SB00211A26	
			SCALE:1:5	SHEET 18 OF 84

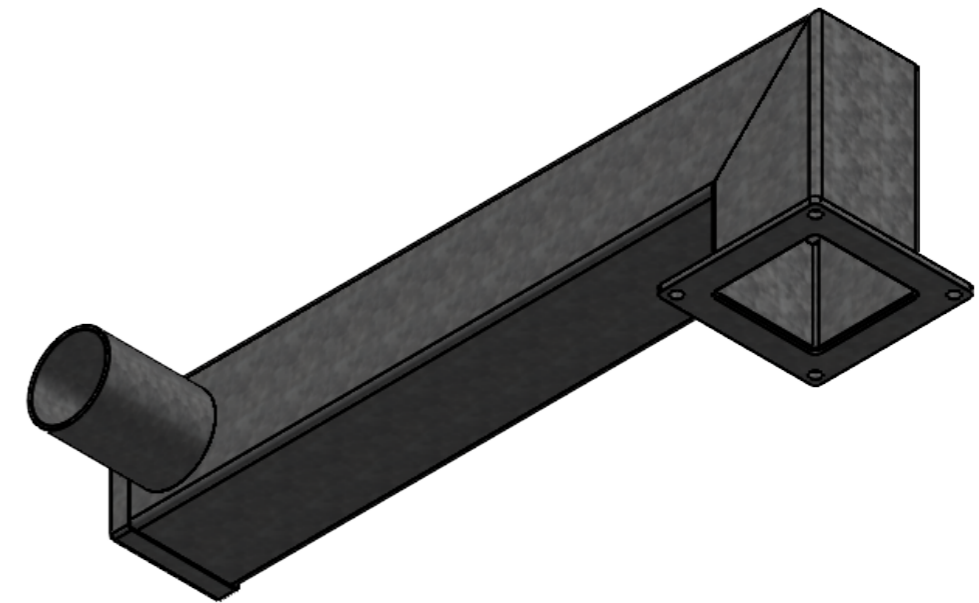
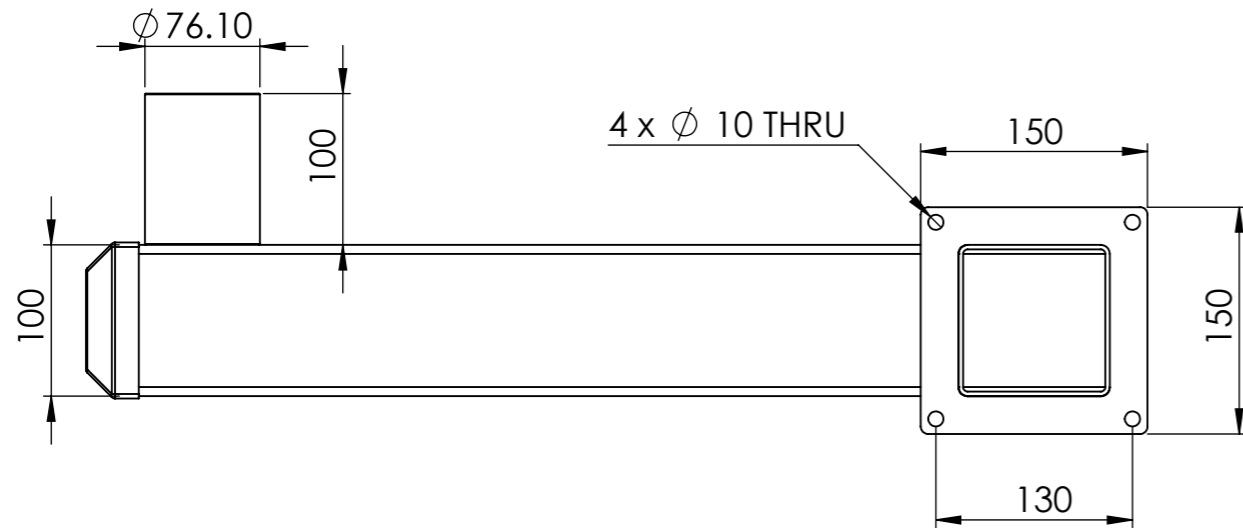
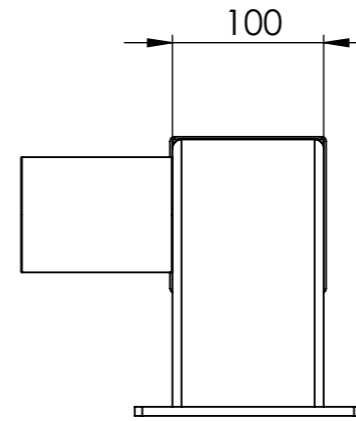
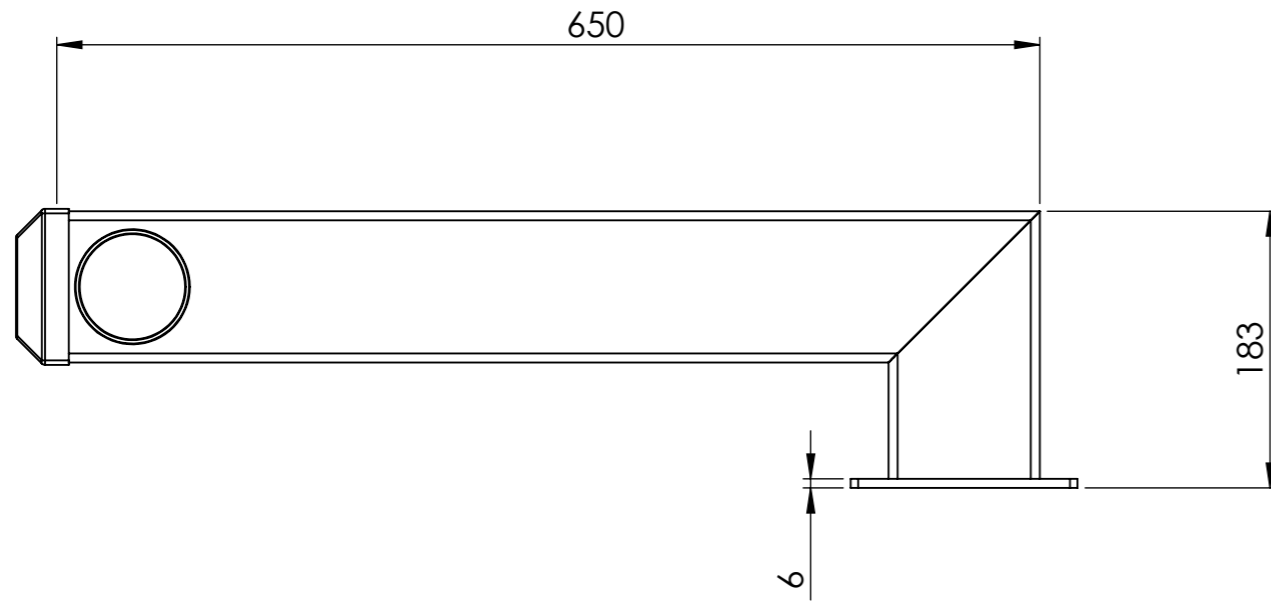

UNLESS OTHERWISE SPECIFIED: DIMENSIONS ARE IN MILLIMETERS	PROPRIETARY AND CONFIDENTIAL THE INFORMATION CONTAINED IN THIS DRAWING IS THE SOLE PROPERTY OF SEE SECURITY PTY LTD. ANY REPRODUCTION IN PART OR AS A WHOLE WITHOUT THE WRITTEN PERMISSION OF SEE SECURITY PTY LTD IS PROHIBITED.	DEBUR AND BREAK SHARP EDGES	DO NOT SCALE DRAWING	REVISION
FINISH:			 SEE SECURITY SECURITY & EQUIPMENT ENCLOSURES	
NAME	SIGNATURE	DATE		
DRAWN	ADC	14/10/2016	DWG NO.	A3
MATERIAL:	Weight		SB00211A27	
Steel galvanised	8kg		SCALE:1:5	SHEET 19 OF 84

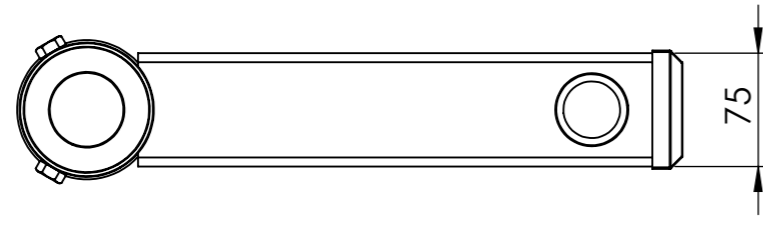
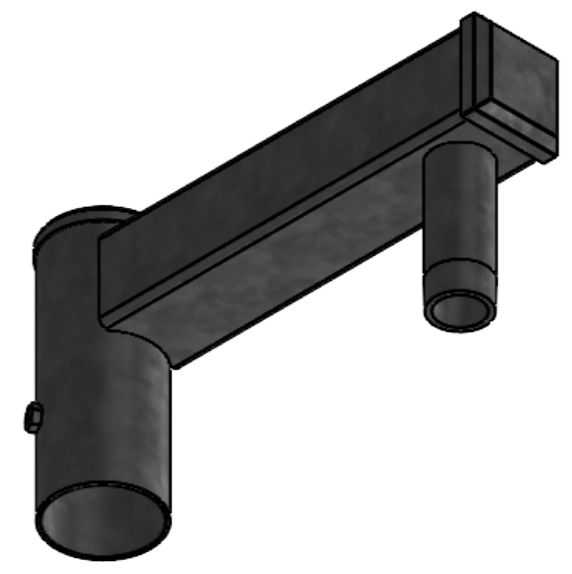
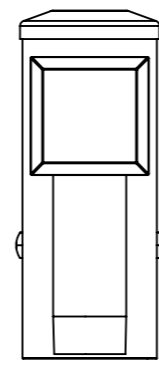
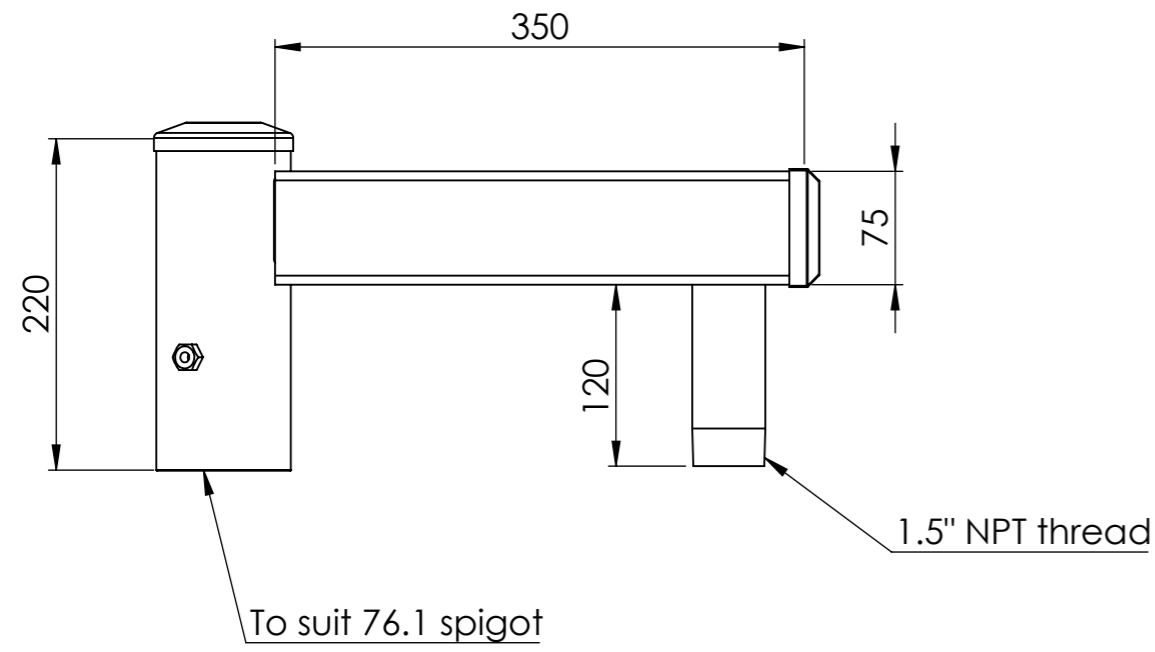

UNLESS OTHERWISE SPECIFIED: DIMENSIONS ARE IN MILLIMETERS	PROPRIETARY AND CONFIDENTIAL THE INFORMATION CONTAINED IN THIS DRAWING IS THE SOLE PROPERTY OF SEE SECURITY PTY LTD. ANY REPRODUCTION IN PART OR AS A WHOLE WITHOUT THE WRITTEN PERMISSION OF SEE SECURITY PTY LTD IS PROHIBITED.	DEBUR AND BREAK SHARP EDGES	DO NOT SCALE DRAWING	REVISION
FINISH:				
NAME	SIGNATURE	DATE		
DRAWN	ADC	14/10/2016		
MATERIAL:	Weight		DWG NO.	A3
Steel galvanised	4.9kg		SB00211A29	
			SCALE:1:5	SHEET 20 OF 84

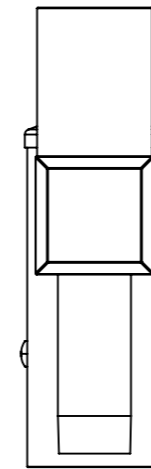
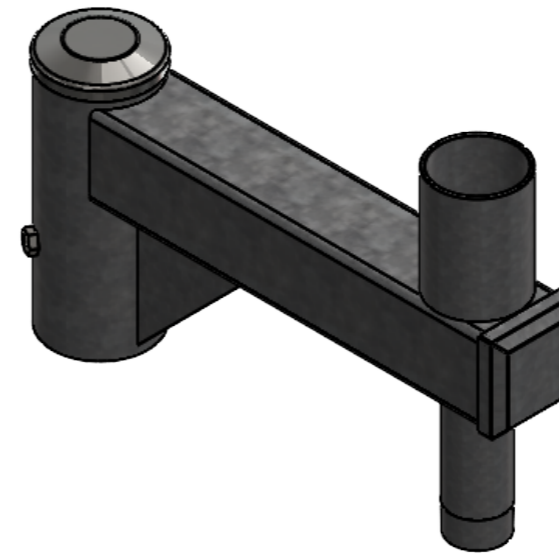
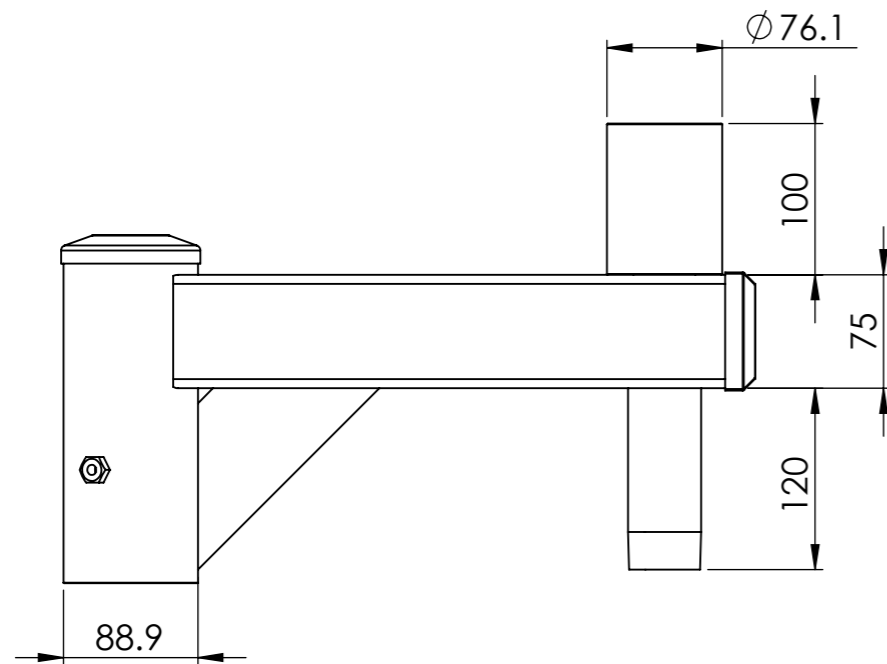
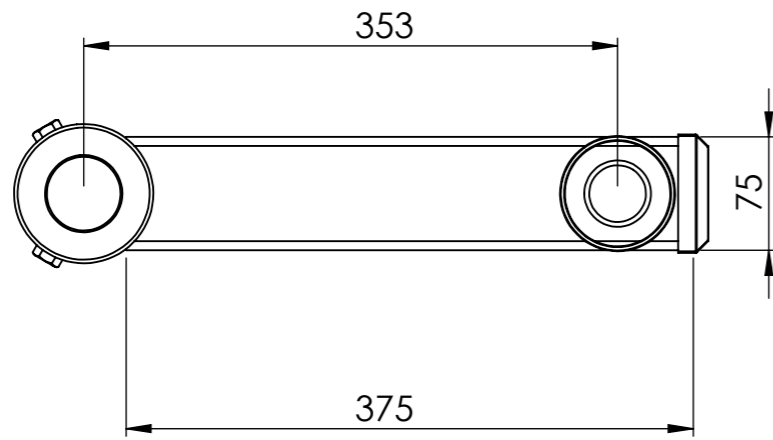

UNLESS OTHERWISE SPECIFIED: DIMENSIONS ARE IN MILLIMETERS		PROPRIETARY AND CONFIDENTIAL THE INFORMATION CONTAINED IN THIS DRAWING IS THE SOLE PROPERTY OF SEE SECURITY PTY LTD. ANY REPRODUCTION IN PART OR AS A WHOLE WITHOUT THE WRITTEN PERMISSION OF SEE SECURITY PTY LTD IS PROHIBITED.		DEBUR AND BREAK SHARP EDGES	DO NOT SCALE DRAWING	REVISION
FINISH:		NAME SIGNATURE DATE		 SEE SECURITY SECURITY & EQUIPMENT ENCLOSURES		
DRAWN ADC		14/10/2016				
MATERIAL: Steel galvanised		Weight 5.5kg		DWG NO.	SB00211A30	A3
				SCALE:1:5	SHEET 21 OF 84	

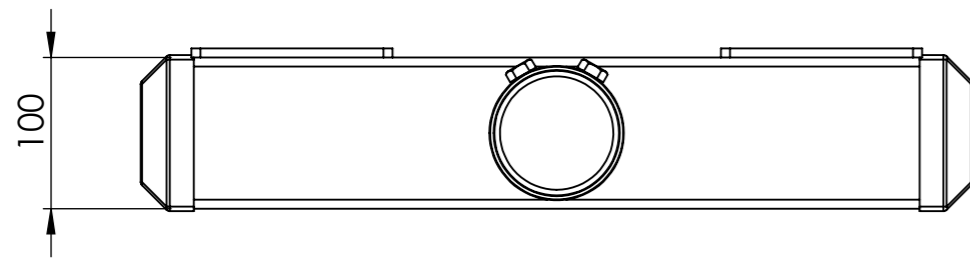
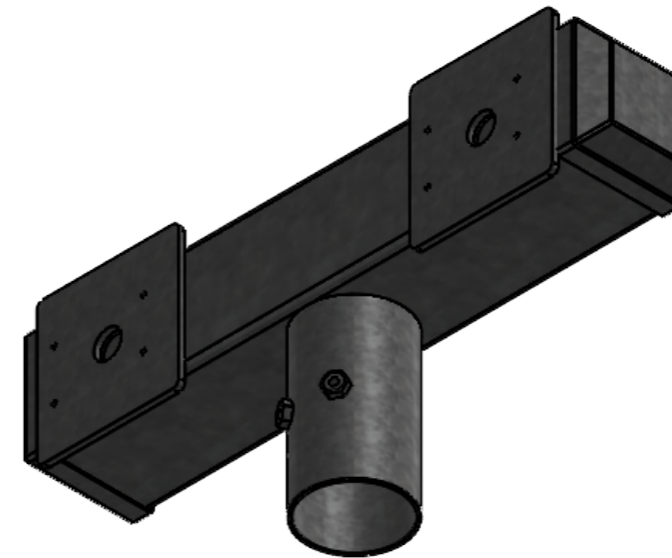
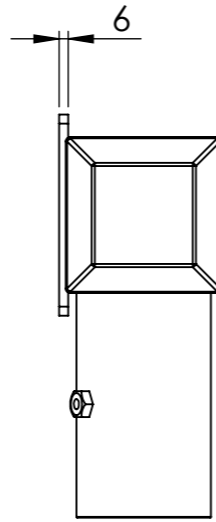
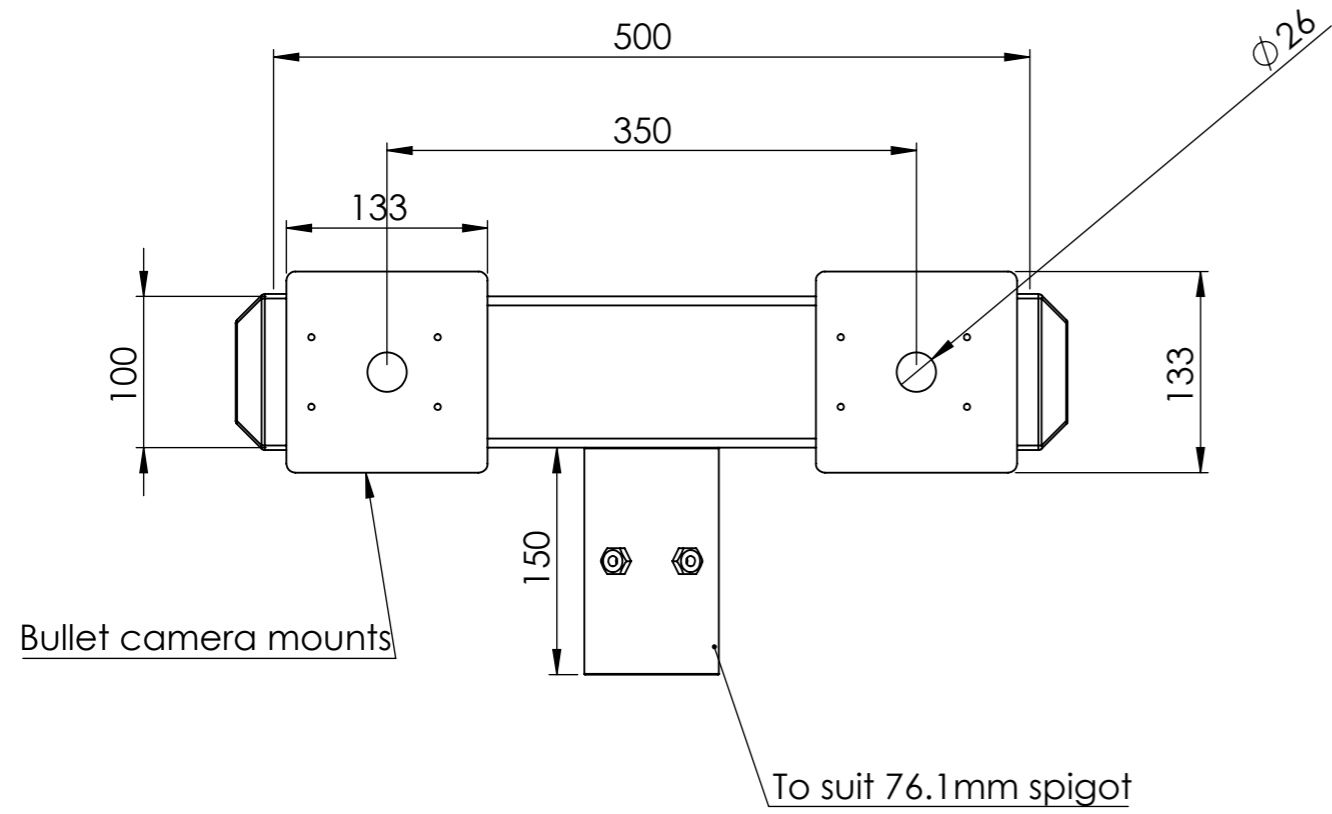

UNLESS OTHERWISE SPECIFIED: DIMENSIONS ARE IN MILLIMETERS	PROPRIETARY AND CONFIDENTIAL THE INFORMATION CONTAINED IN THIS DRAWING IS THE SOLE PROPERTY OF SEE SECURITY PTY LTD. ANY REPRODUCTION IN PART OR AS A WHOLE WITHOUT THE WRITTEN PERMISSION OF SEE SECURITY PTY LTD IS PROHIBITED.	DEBUR AND BREAK SHARP EDGES	DO NOT SCALE DRAWING	REVISION
FINISH:				
NAME	SIGNATURE	DATE		
DRAWN	ADC	14/10/2016		
MATERIAL:	Weight	DWG NO.		
Steel Galvanised	6.5 kg	SB00211A31		A3
		SCALE:1:5	SHEET 22 OF 84	

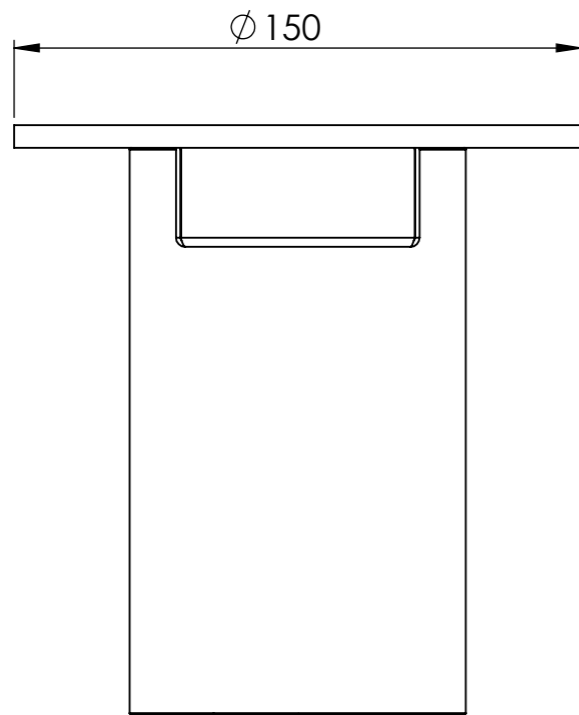
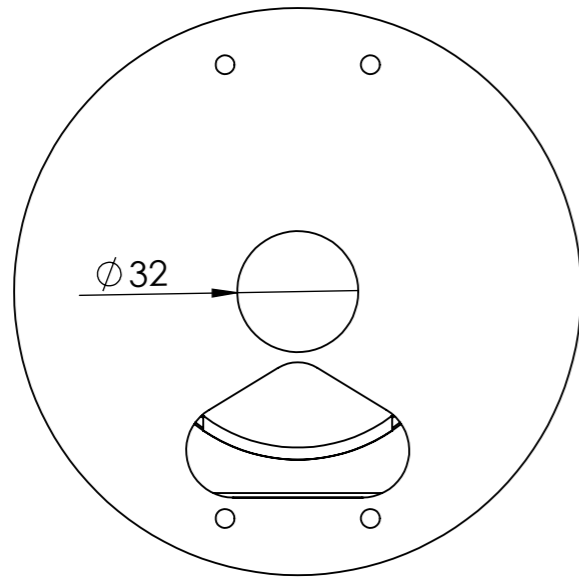

to suit 76.1 spigot

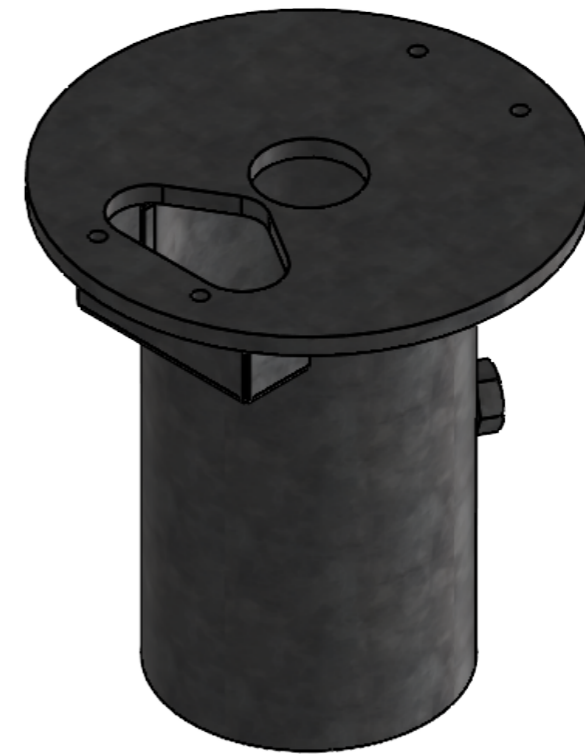
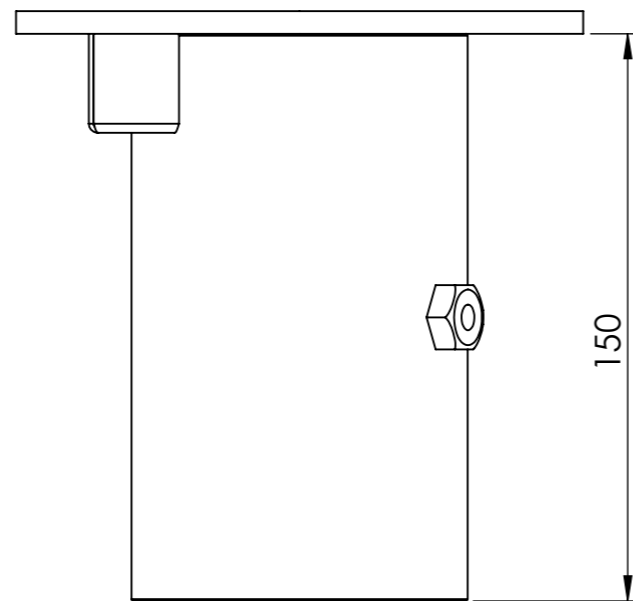

UNLESS OTHERWISE SPECIFIED: DIMENSIONS ARE IN MILLIMETERS		PROPRIETARY AND CONFIDENTIAL THE INFORMATION CONTAINED IN THIS DRAWING IS THE SOLE PROPERTY OF SEE SECURITY PTY LTD. ANY REPRODUCTION IN PART OR AS A WHOLE WITHOUT THE WRITTEN PERMISSION OF SEE SECURITY PTY LTD IS PROHIBITED.		DEBUR AND BREAK SHARP EDGES	DO NOT SCALE DRAWING	REVISION
FINISH:		NAME SIGNATURE DATE				A3
DRAWN ADC 14/10/2016		MATERIAL: Steel galvanised				
				SCALE:1:5	SHEET 23 OF 84	

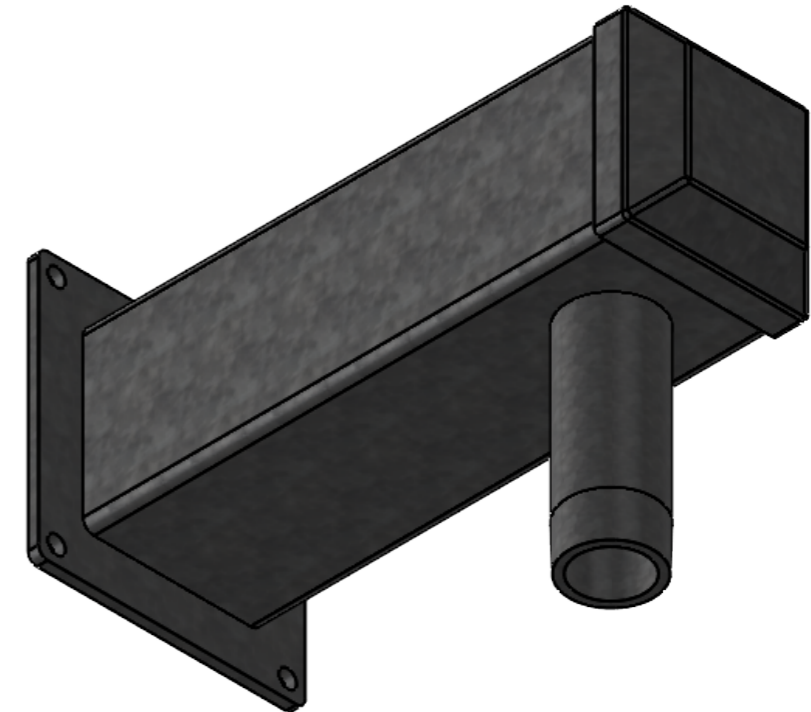
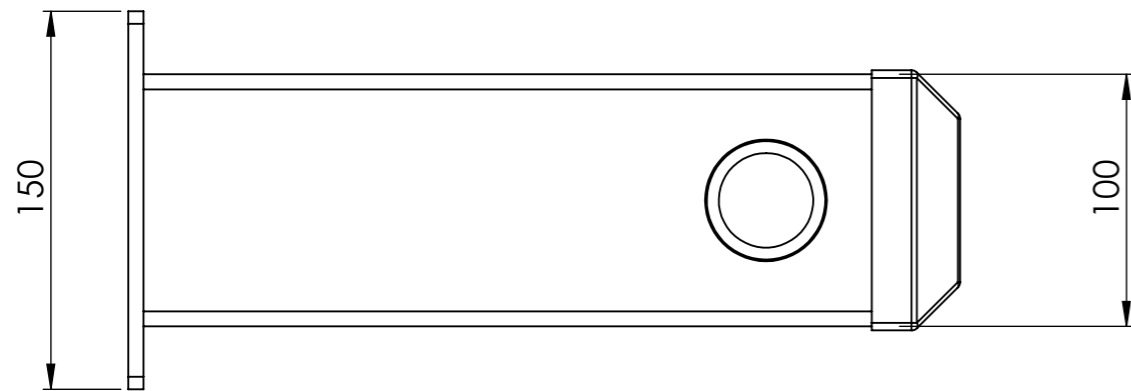
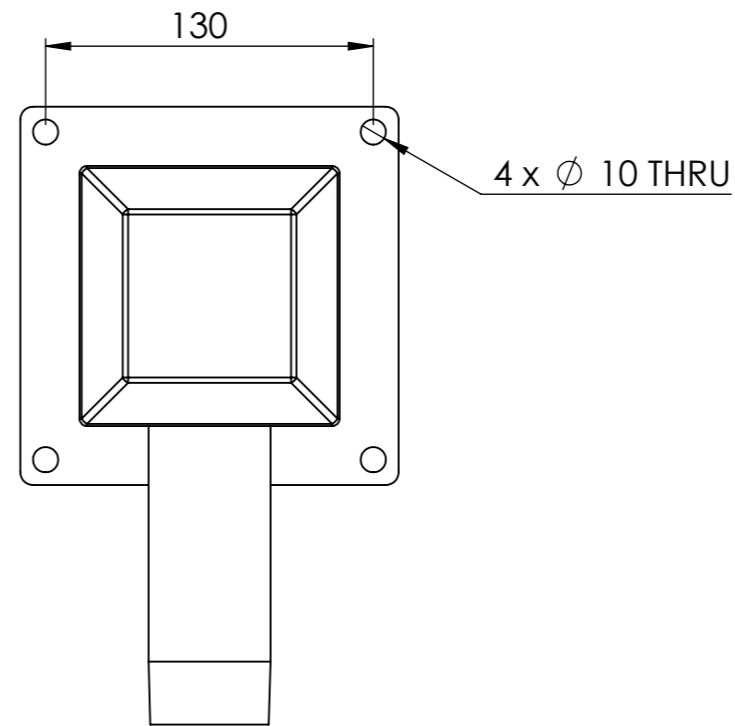
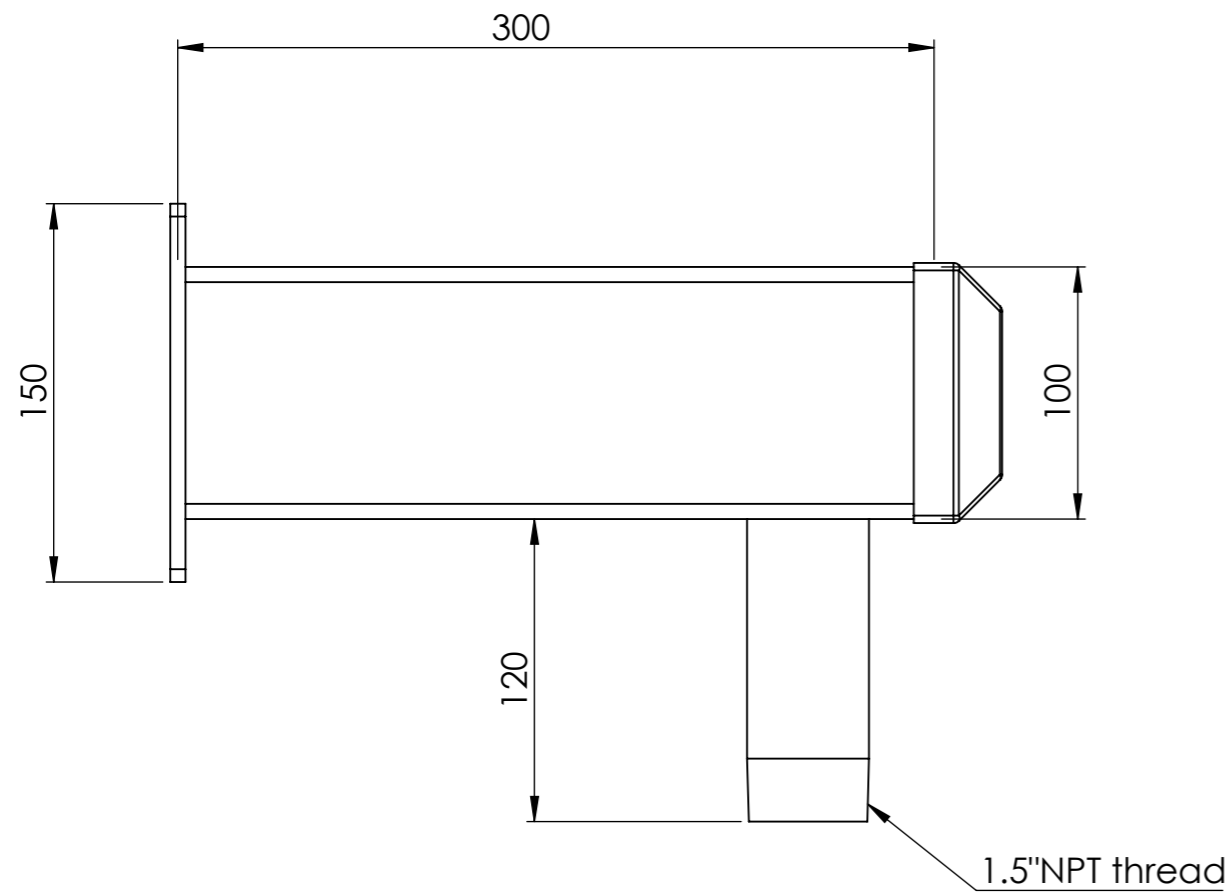

UNLESS OTHERWISE SPECIFIED: DIMENSIONS ARE IN MILLIMETERS	PROPRIETARY AND CONFIDENTIAL THE INFORMATION CONTAINED IN THIS DRAWING IS THE SOLE PROPERTY OF SEE SECURITY PTY LTD. ANY REPRODUCTION IN PART OR AS A WHOLE WITHOUT THE WRITTEN PERMISSION OF SEE SECURITY PTY LTD IS PROHIBITED.	DEBUR AND BREAK SHARP EDGES	DO NOT SCALE DRAWING	REVISION
FINISH:				
NAME	SIGNATURE	DATE		
DRAWN	ADC	14/10/2016		
MATERIAL: Steel Galvanised	Weight 4kg	DWG NO. SB00211A34		A3
		SCALE:1:5	SHEET 24 OF 84	

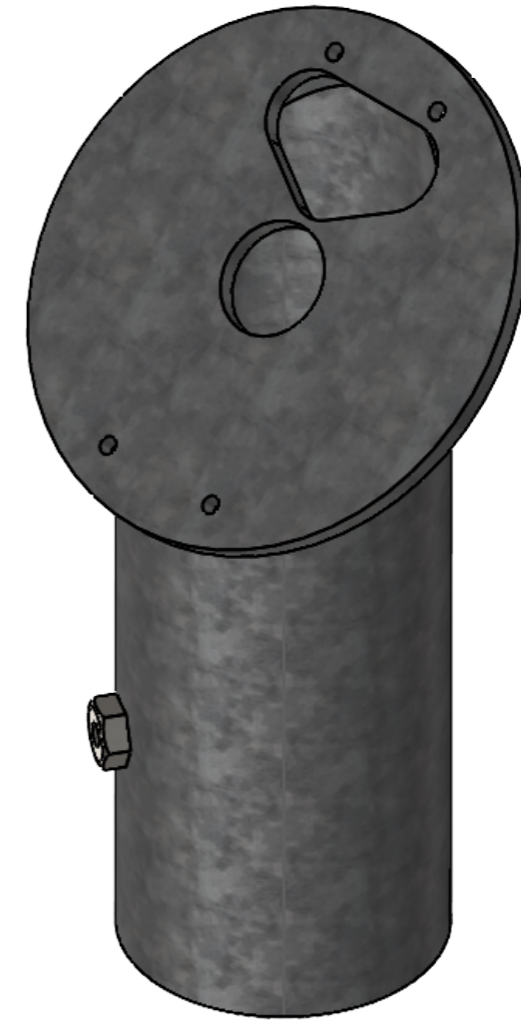
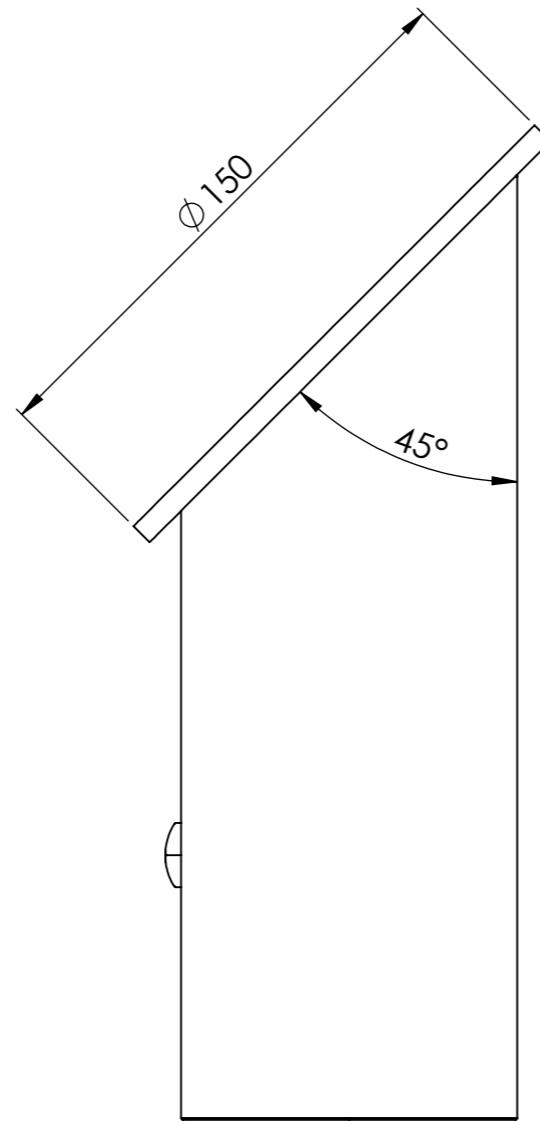
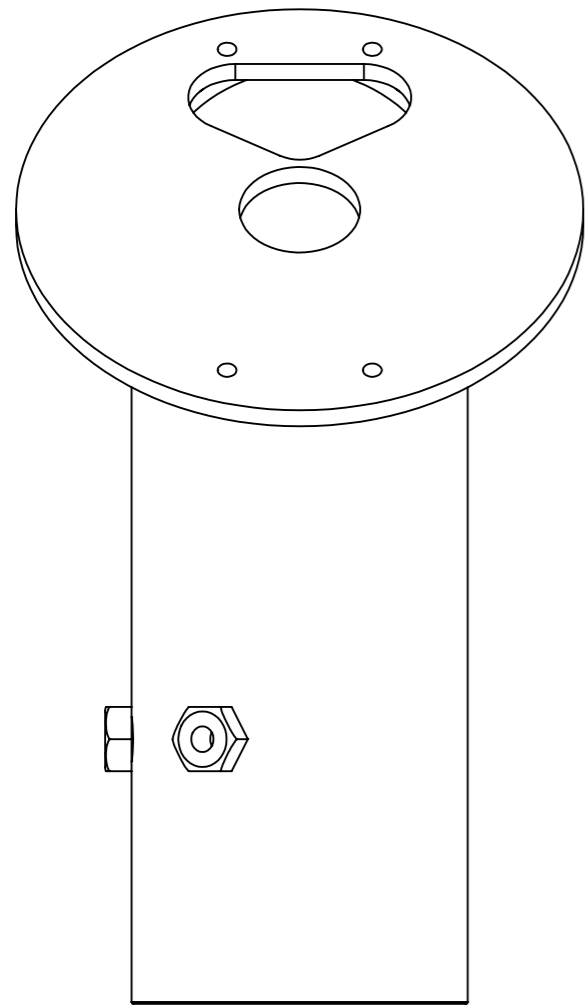
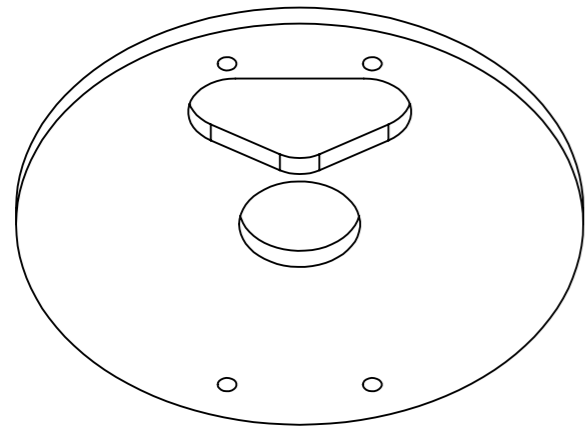

UNLESS OTHERWISE SPECIFIED: DIMENSIONS ARE IN MILLIMETERS		PROPRIETARY AND CONFIDENTIAL THE INFORMATION CONTAINED IN THIS DRAWING IS THE SOLE PROPERTY OF SEE SECURITY PTY LTD. ANY REPRODUCTION IN PART OR AS A WHOLE WITHOUT THE WRITTEN PERMISSION OF SEE SECURITY PTY LTD IS PROHIBITED.		DEBUR AND BREAK SHARP EDGES	DO NOT SCALE DRAWING	REVISION
FINISH:		NAME SIGNATURE DATE				
DRAWN ADC 14/10/2016						
MATERIAL: Steel galvanised		Weight 1kg		DWG NO. SB00211A35		A3
				SCALE:1:5		SHEET 25 OF 84

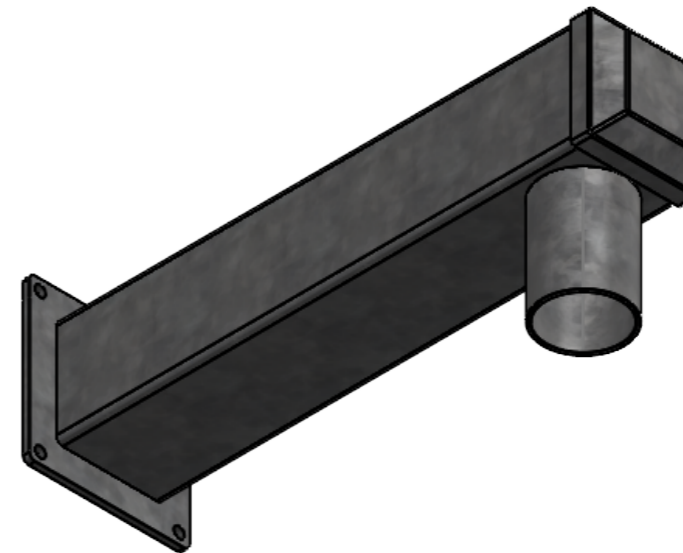
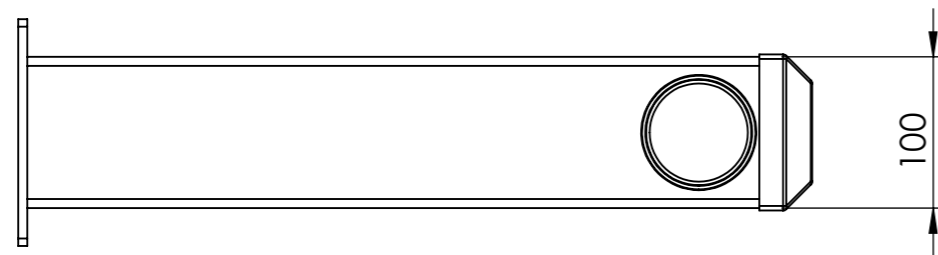
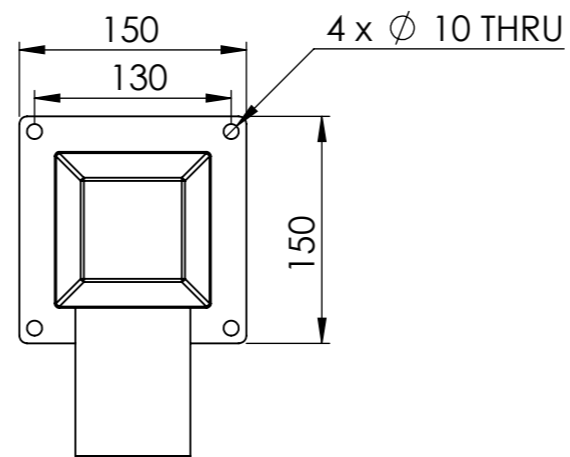
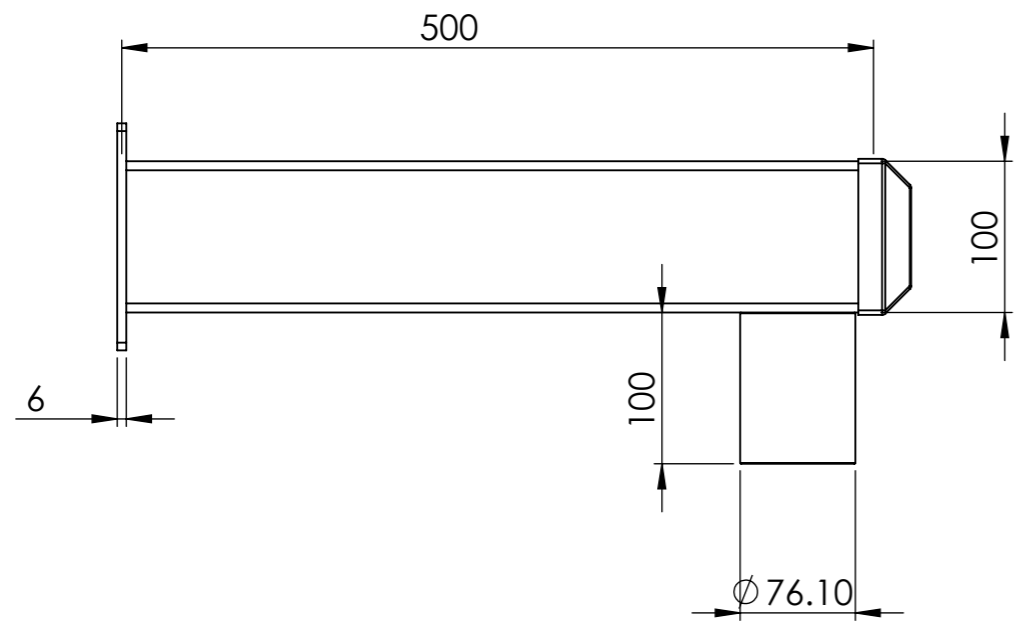

UNLESS OTHERWISE SPECIFIED: DIMENSIONS ARE IN MILLIMETERS	PROPRIETARY AND CONFIDENTIAL THE INFORMATION CONTAINED IN THIS DRAWING IS THE SOLE PROPERTY OF SEE SECURITY PTY LTD. ANY REPRODUCTION IN PART OR AS A WHOLE WITHOUT THE WRITTEN PERMISSION OF SEE SECURITY PTY LTD IS PROHIBITED.	DEBUR AND BREAK SHARP EDGES	DO NOT SCALE DRAWING	REVISION
FINISH:			 SEE SECURITY SECURITY & EQUIPMENT ENCLOSURES	
NAME	SIGNATURE	DATE		
DRAWN	ADC	14/10/2016	DWG NO.	SB00211A38
MATERIAL:	Weight		A3	
Steel Galvanised	6kg		SCALE:1:5	SHEET 26 OF 84

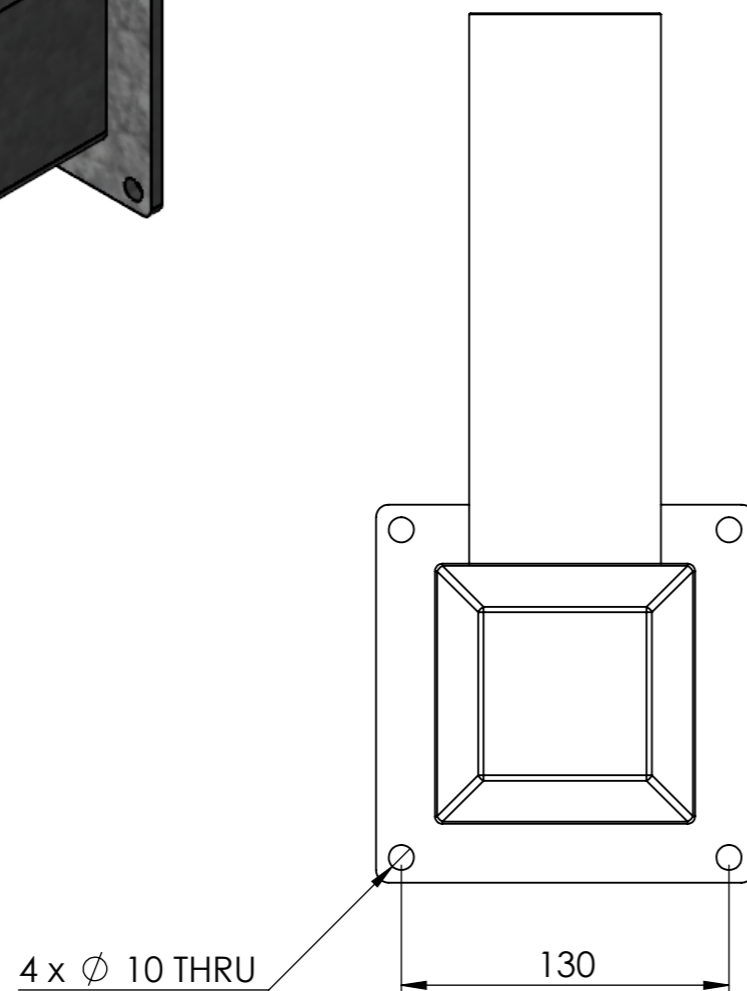
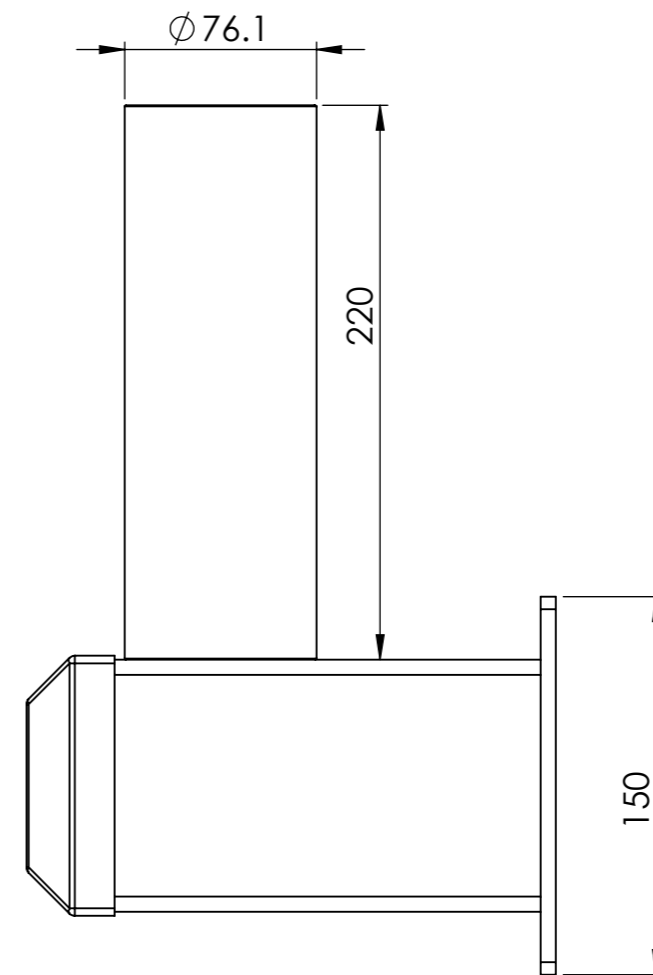
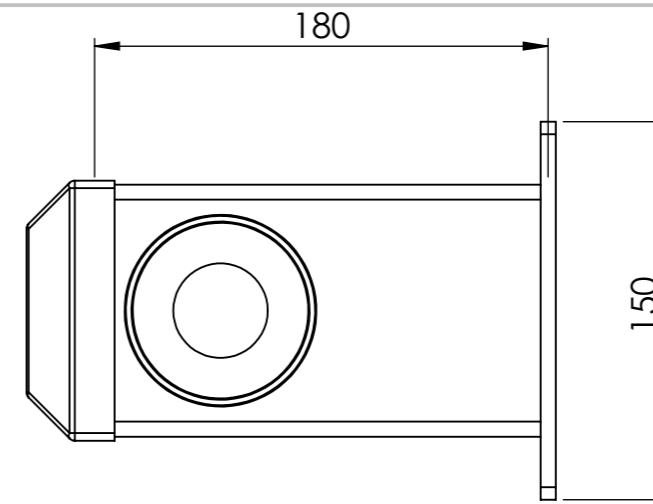
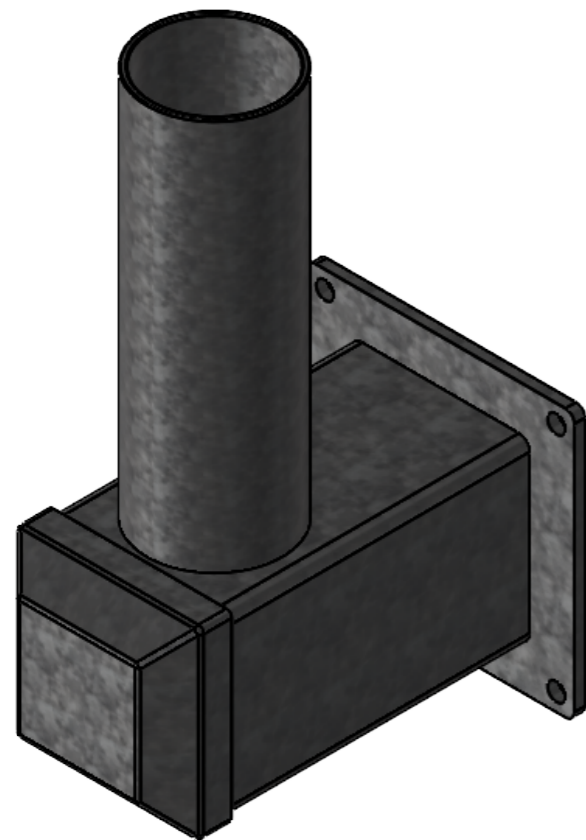

UNLESS OTHERWISE SPECIFIED: DIMENSIONS ARE IN MILLIMETERS		PROPRIETARY AND CONFIDENTIAL THE INFORMATION CONTAINED IN THIS DRAWING IS THE SOLE PROPERTY OF SEE SECURITY PTY LTD. ANY REPRODUCTION IN PART OR AS A WHOLE WITHOUT THE WRITTEN PERMISSION OF SEE SECURITY PTY LTD IS PROHIBITED.		DEBUR AND BREAK SHARP EDGES	DO NOT SCALE DRAWING	REVISION
FINISH:		NAME SIGNATURE DATE				A3
DRAWN ADC 14/10/2016		MATERIAL: Weight				
Steel galvanised		4kg		DWG NO. SB00211A41		SCALE:1:5
				SHEET 27 OF 84		

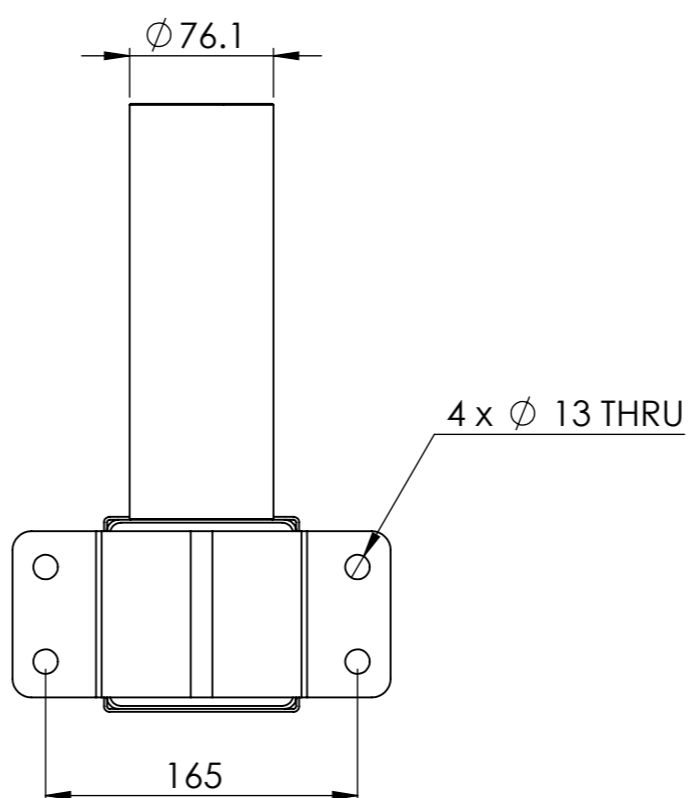
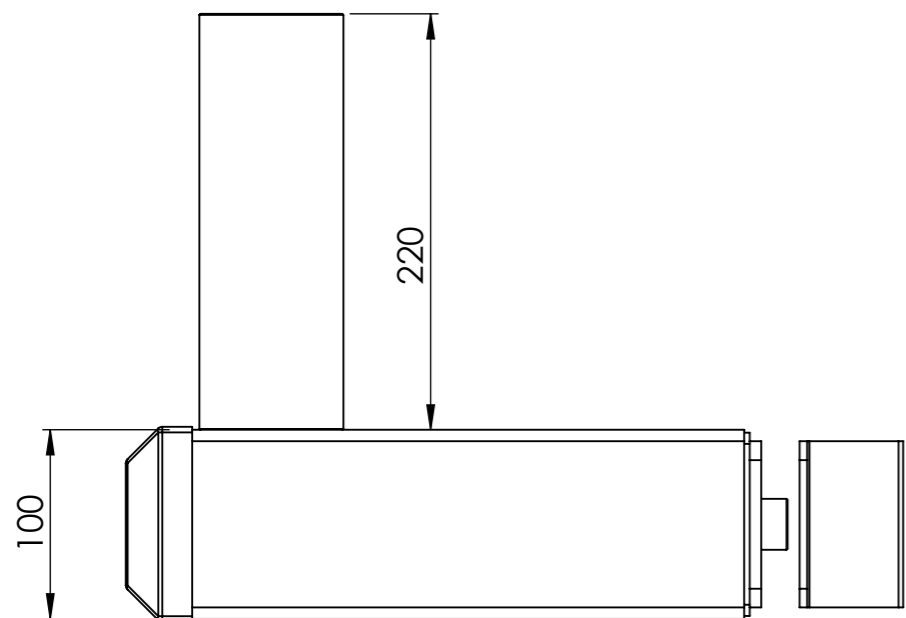
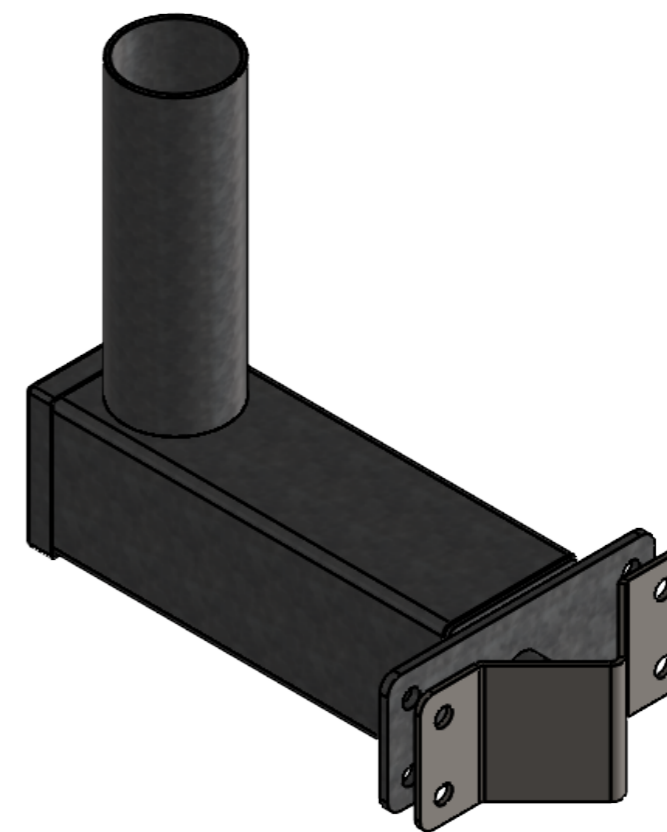
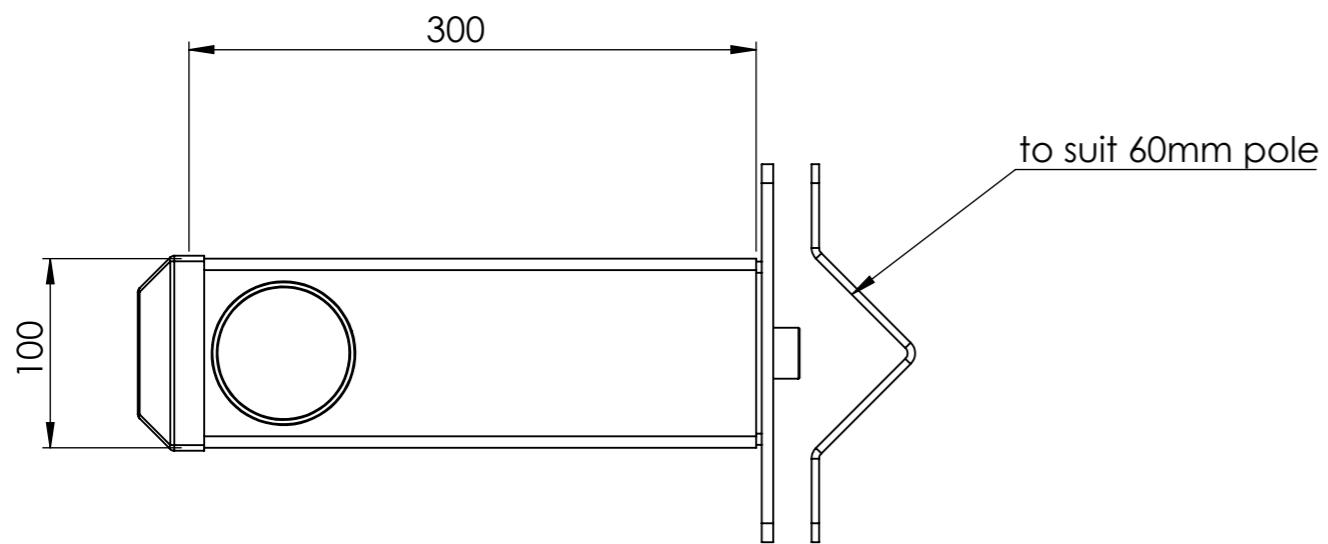

UNLESS OTHERWISE SPECIFIED: DIMENSIONS ARE IN MILLIMETERS	PROPRIETARY AND CONFIDENTIAL THE INFORMATION CONTAINED IN THIS DRAWING IS THE SOLE PROPERTY OF SEE SECURITY PTY LTD. ANY REPRODUCTION IN PART OR AS A WHOLE WITHOUT THE WRITTEN PERMISSION OF SEE SECURITY PTY LTD IS PROHIBITED.	DEBUR AND BREAK SHARP EDGES	DO NOT SCALE DRAWING	REVISION
FINISH:				
NAME	SIGNATURE	DATE		
DRAWN	ADC	14/10/2016		
MATERIAL:	Weight		DWG NO.	A3
steel galvanised	5kg		SB00211A43	
			SCALE:1:5	SHEET 28 OF 84

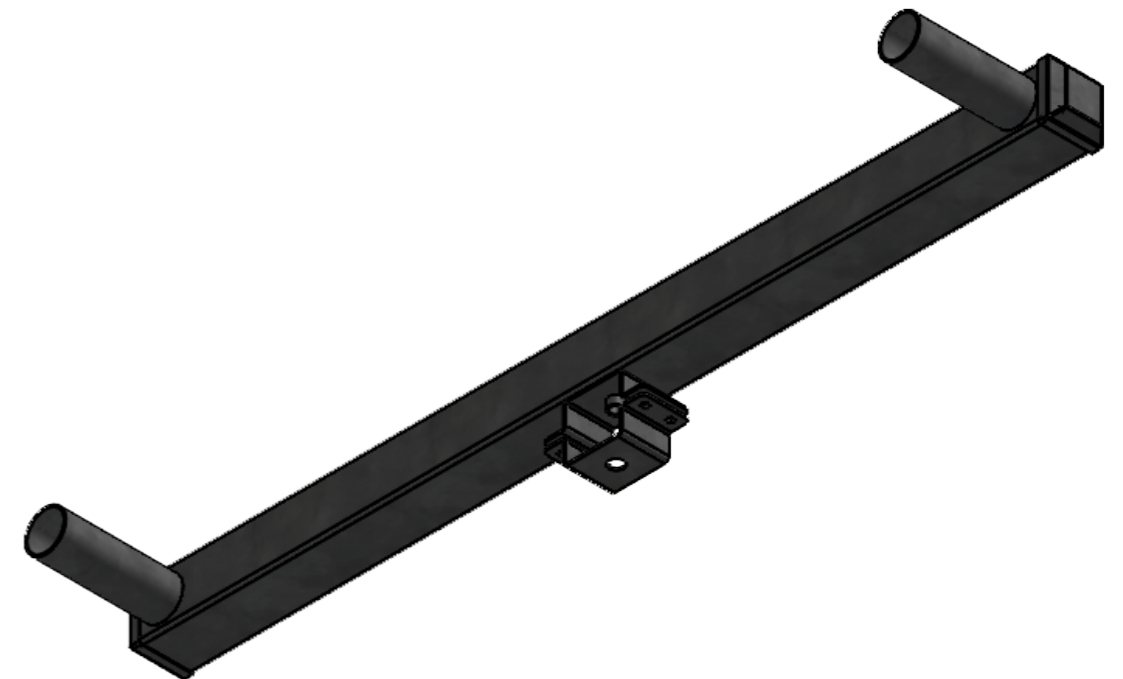
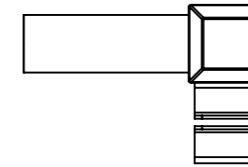
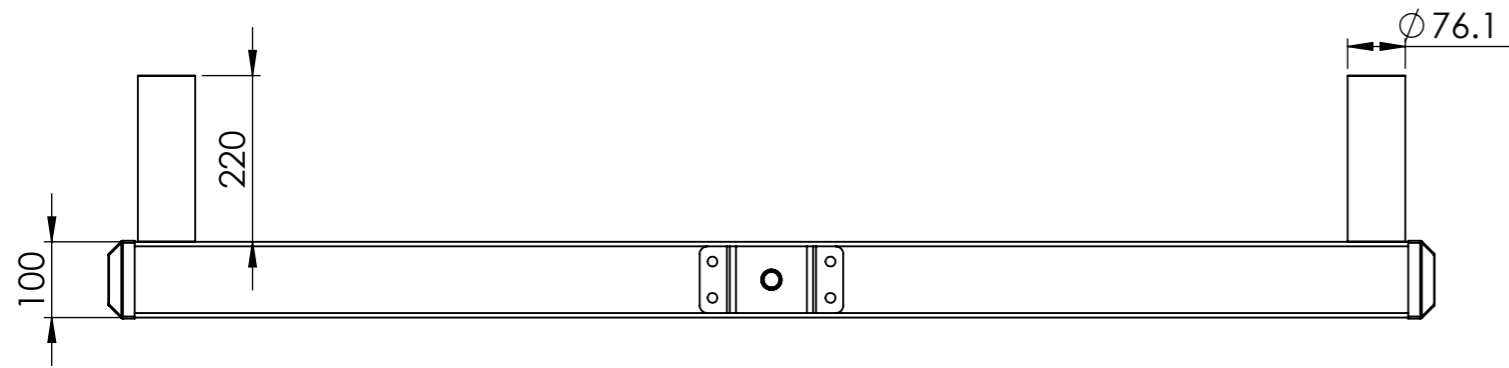
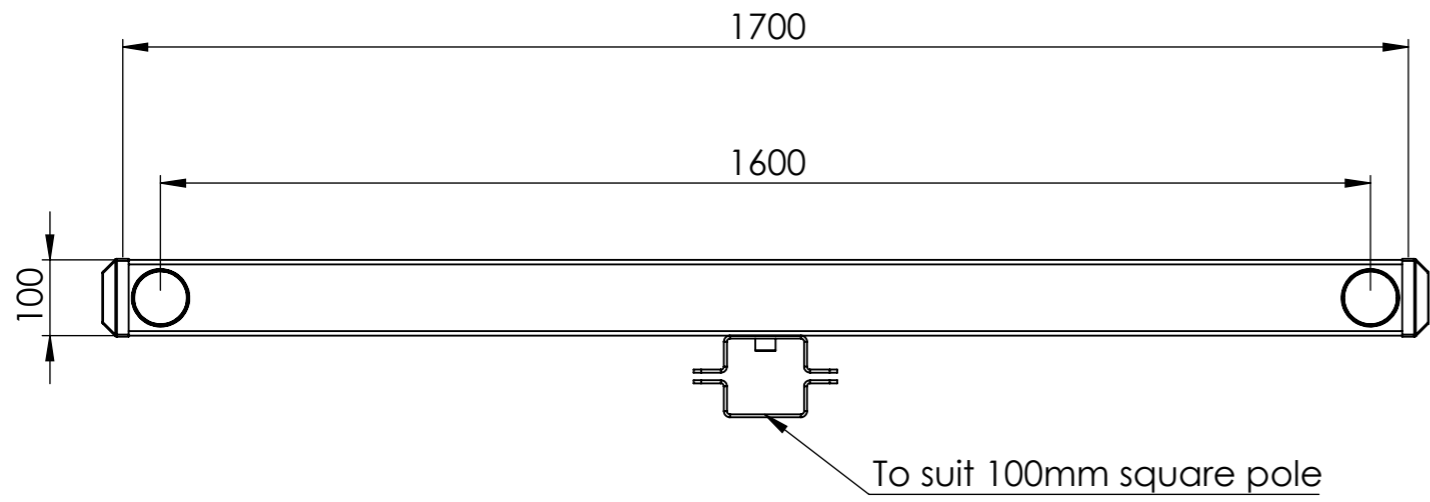

UNLESS OTHERWISE SPECIFIED: DIMENSIONS ARE IN MILLIMETERS	PROPRIETARY AND CONFIDENTIAL THE INFORMATION CONTAINED IN THIS DRAWING IS THE SOLE PROPERTY OF SEE SECURITY PTY LTD. ANY REPRODUCTION IN PART OR AS A WHOLE WITHOUT THE WRITTEN PERMISSION OF SEE SECURITY PTY LTD IS PROHIBITED.	DEBUR AND BREAK SHARP EDGES	DO NOT SCALE DRAWING	REVISION
FINISH:				
NAME	SIGNATURE	DATE		
DRAWN	ADC	14/10/2016		
MATERIAL:	Weight	DWG NO.		
Steel galvanised	20kg	SB00211A44		A3
		SCALE:1:5	SHEET 29 OF 84	

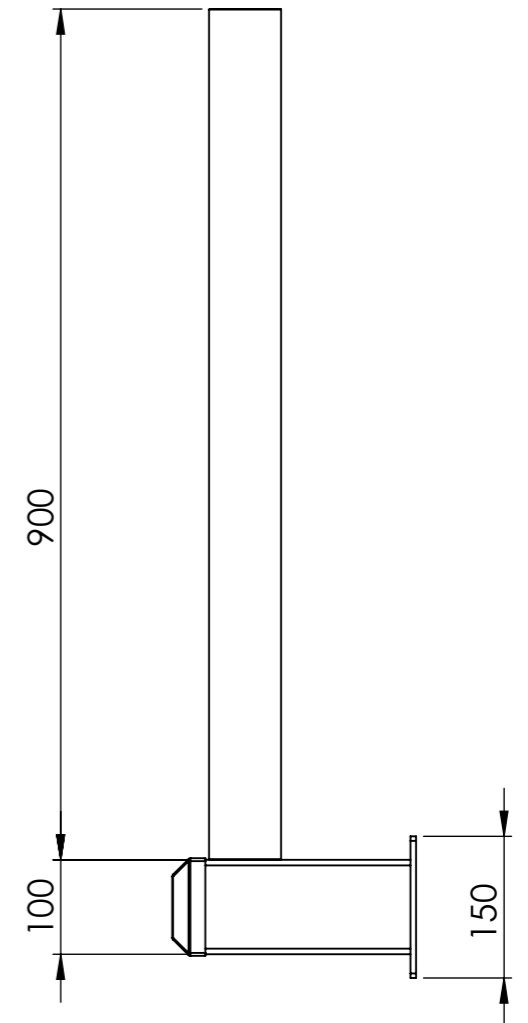
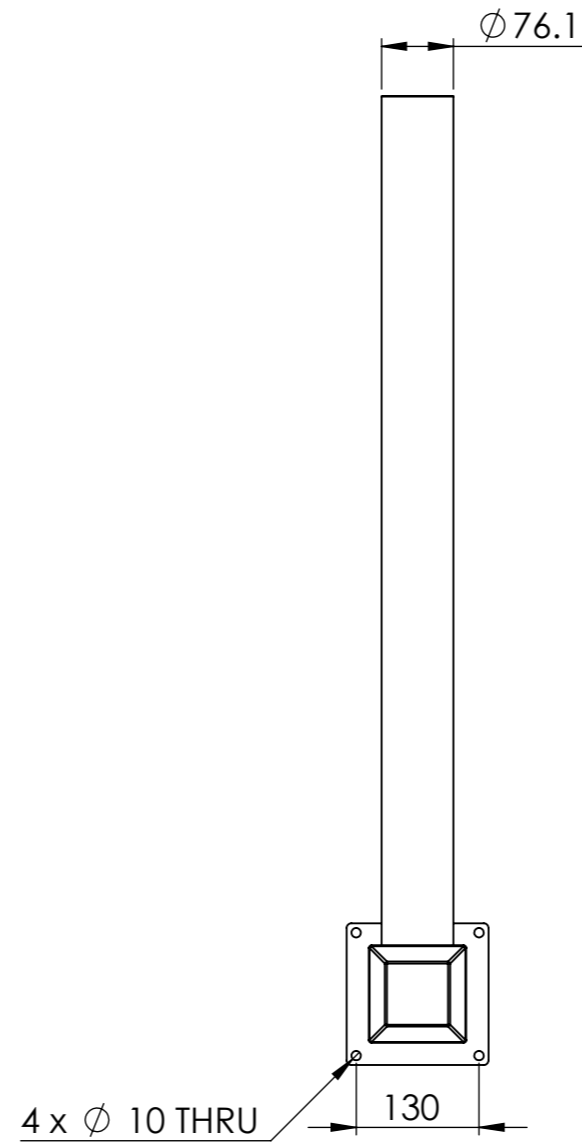
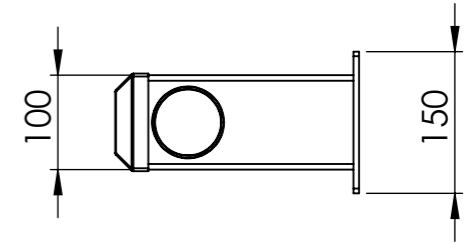
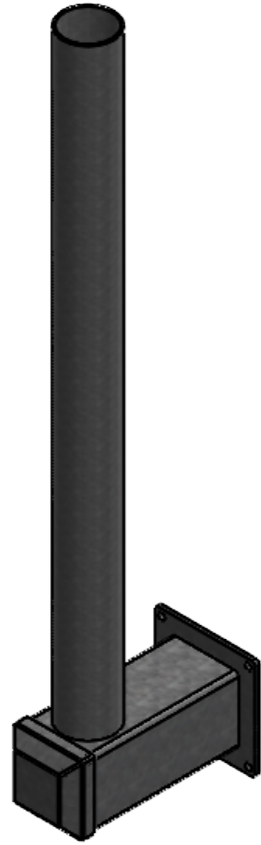

UNLESS OTHERWISE SPECIFIED: DIMENSIONS ARE IN MILLIMETERS		PROPRIETARY AND CONFIDENTIAL THE INFORMATION CONTAINED IN THIS DRAWING IS THE SOLE PROPERTY OF SEE SECURITY PTY LTD. ANY REPRODUCTION IN PART OR AS A WHOLE WITHOUT THE WRITTEN PERMISSION OF SEE SECURITY PTY LTD IS PROHIBITED.		DEBUR AND BREAK SHARP EDGES	DO NOT SCALE DRAWING	REVISION
FINISH:		NAME SIGNATURE DATE				A3
DRAWN ADC		14/10/2016				
MATERIAL: Steel galvanised		Weight 8kg		DWG NO. SB00211A46		
				SCALE:1:5		SHEET 30 OF 84

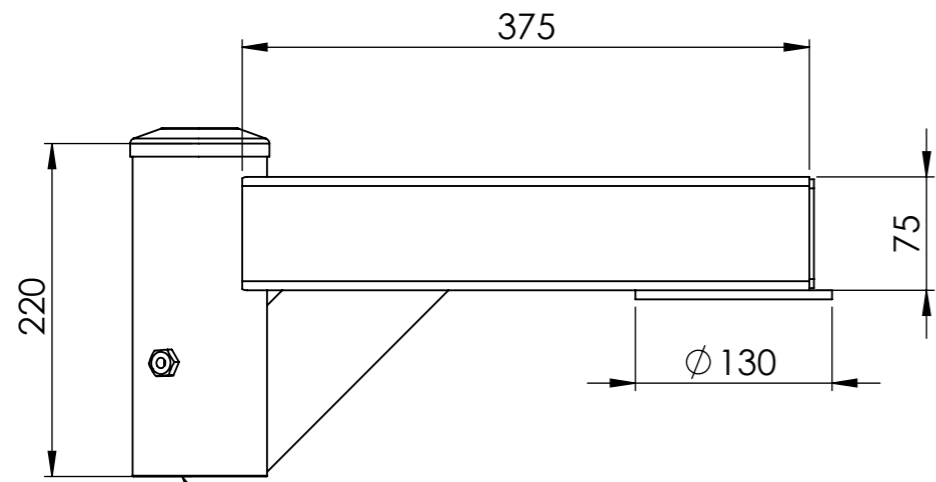

To suit 76.1 spigot

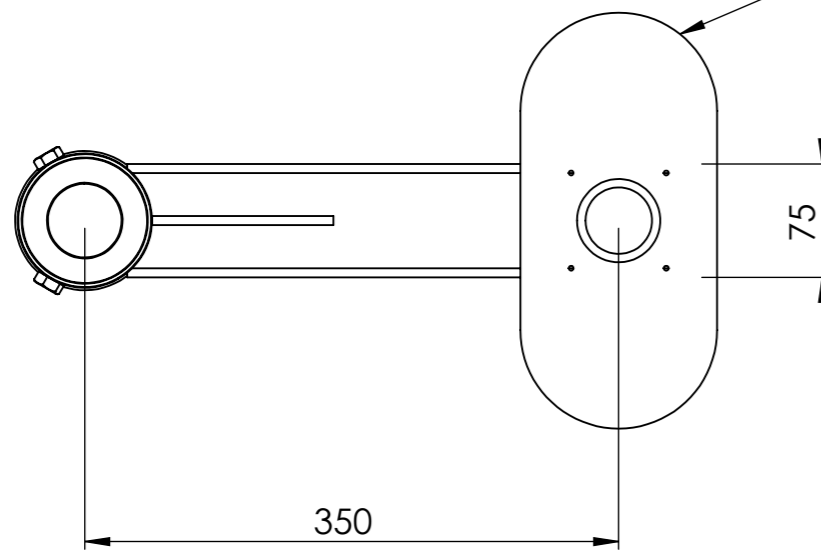
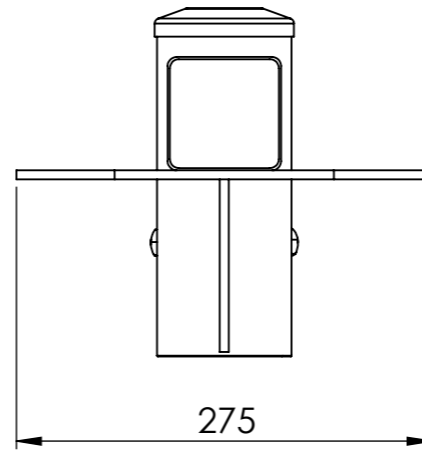

To suit Axis dual camera

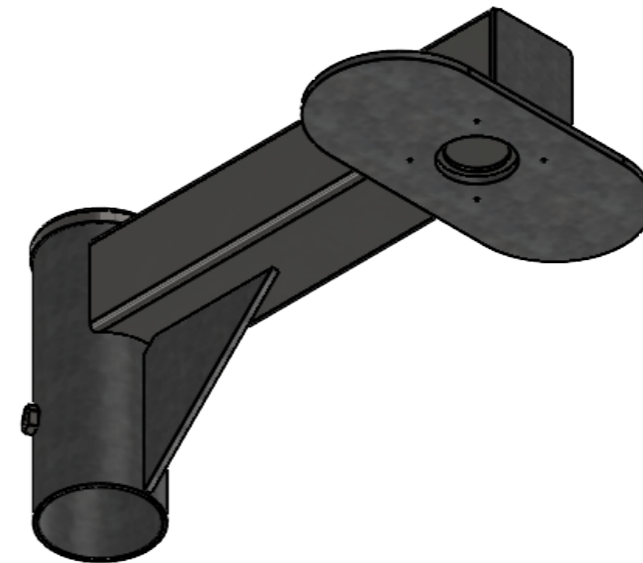

UNLESS OTHERWISE SPECIFIED: DIMENSIONS ARE IN MILLIMETERS	PROPRIETARY AND CONFIDENTIAL THE INFORMATION CONTAINED IN THIS DRAWING IS THE SOLE PROPERTY OF SEE SECURITY PTY LTD. ANY REPRODUCTION IN PART OR AS A WHOLE WITHOUT THE WRITTEN PERMISSION OF SEE SECURITY PTY LTD IS PROHIBITED.	DEBUR AND BREAK SHARP EDGES	DO NOT SCALE DRAWING	REVISION
FINISH:				
NAME	SIGNATURE	DATE		
DRAWN	ADC	14/10/2016		
MATERIAL: Steel galvanised	Weight 5.8kg	DWG NO. SB00211A48		A3
		SCALE:1:5	SHEET 31 OF 84	

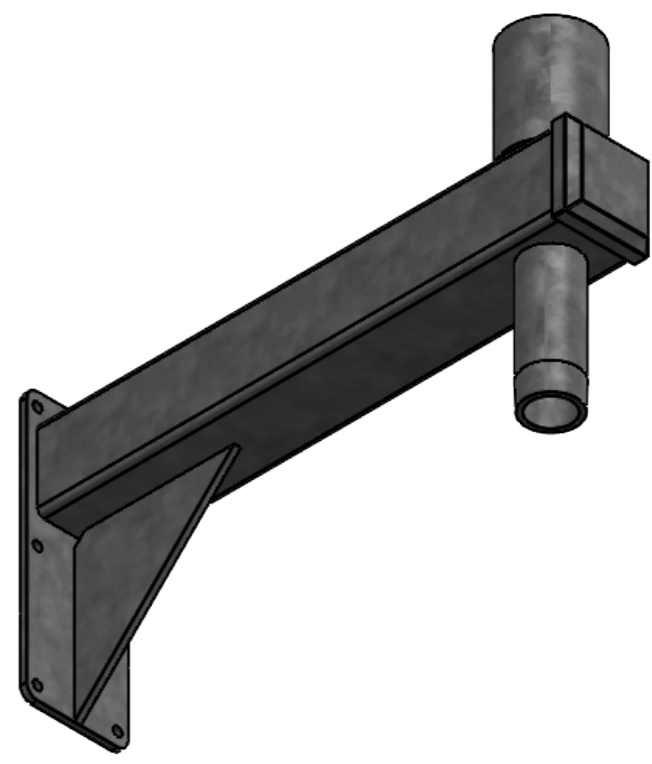
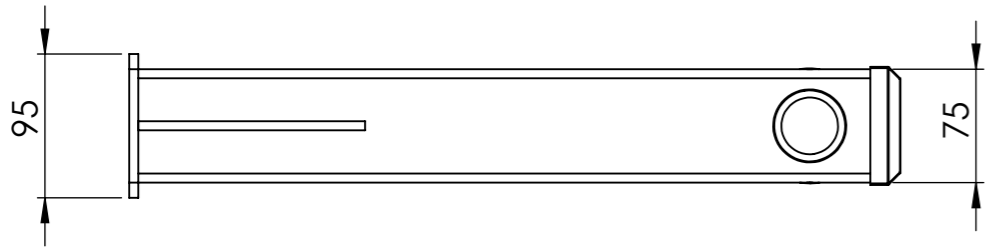
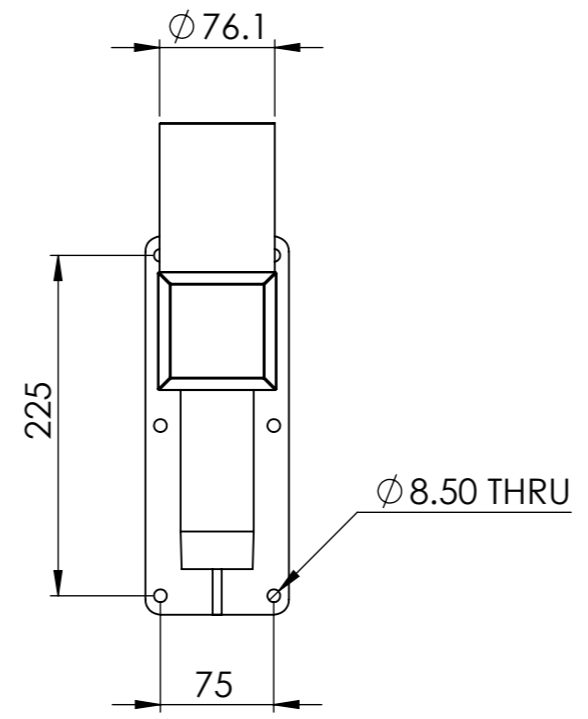
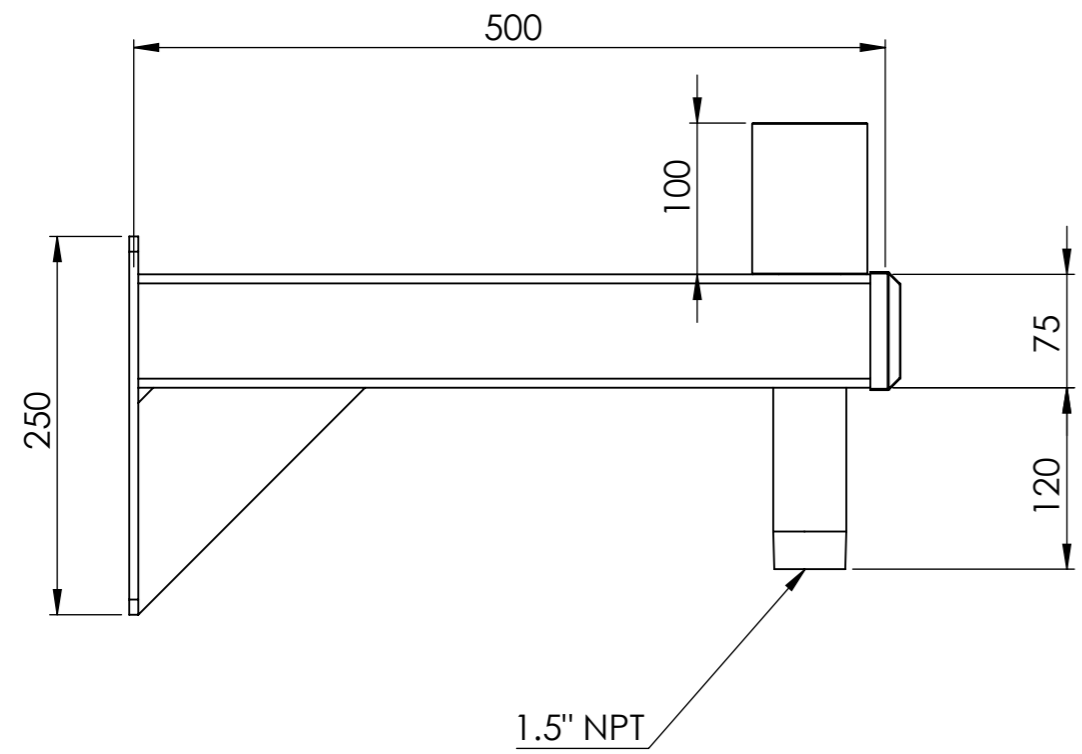

UNLESS OTHERWISE SPECIFIED: DIMENSIONS ARE IN MILLIMETERS	PROPRIETARY AND CONFIDENTIAL THE INFORMATION CONTAINED IN THIS DRAWING IS THE SOLE PROPERTY OF SEE SECURITY PTY LTD. ANY REPRODUCTION IN PART OR AS A WHOLE WITHOUT THE WRITTEN PERMISSION OF SEE SECURITY PTY LTD IS PROHIBITED.	DEBUR AND BREAK SHARP EDGES	DO NOT SCALE DRAWING	REVISION
FINISH:			 SEE SECURITY SECURITY & EQUIPMENT END OFFERS	
NAME	SIGNATURE	DATE		
DRAWN	ADC	14/10/2016	DWG NO.	A3
MATERIAL:	Weight		SB00211A50	
Steel galvanised	6.3kg		SCALE:1:5	SHEET 32 OF 84

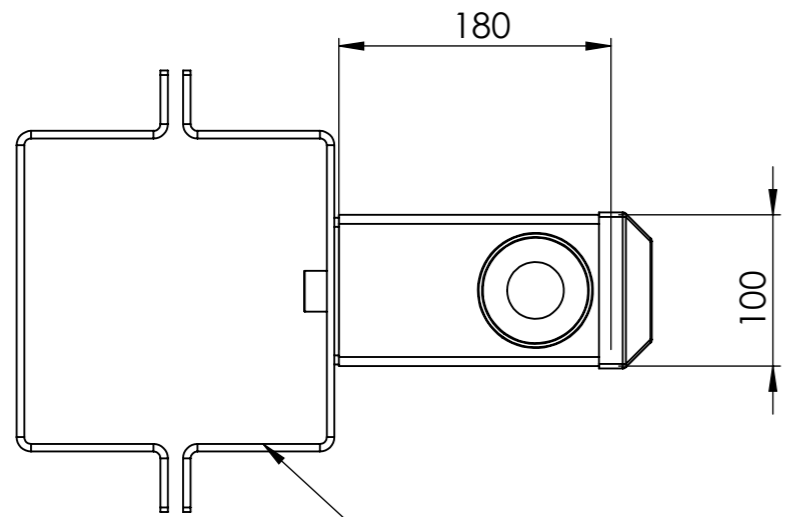

to suit 200mm square pole

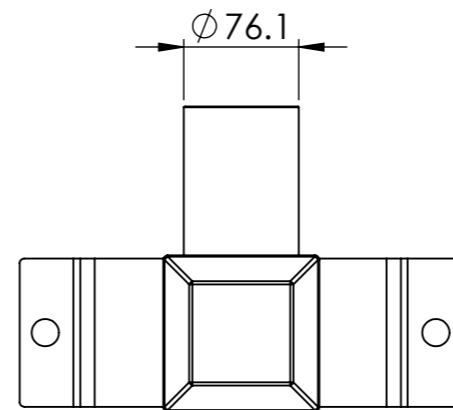
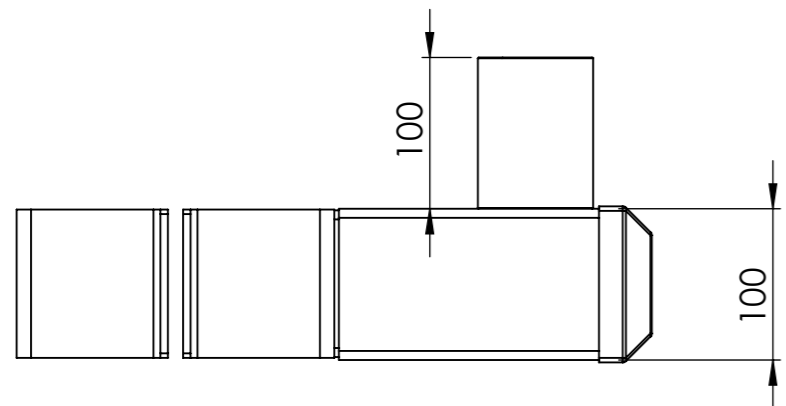
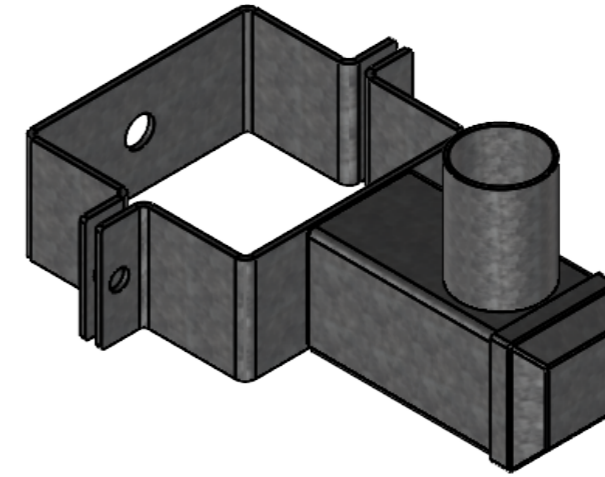

UNLESS OTHERWISE SPECIFIED: DIMENSIONS ARE IN MILLIMETERS	PROPRIETARY AND CONFIDENTIAL THE INFORMATION CONTAINED IN THIS DRAWING IS THE SOLE PROPERTY OF SEE SECURITY PTY LTD. ANY REPRODUCTION IN PART OR AS A WHOLE WITHOUT THE WRITTEN PERMISSION OF SEE SECURITY PTY LTD IS PROHIBITED.	DEBUR AND BREAK SHARP EDGES	DO NOT SCALE DRAWING	REVISION
FINISH:				
NAME	SIGNATURE	DATE		
DRAWN	ADC	14/10/2016		
MATERIAL:	Weight		DWG NO.	A3
Steel galvanised	6.2kg		SB00211A52	
			SCALE:1:5	SHEET 33 OF 84

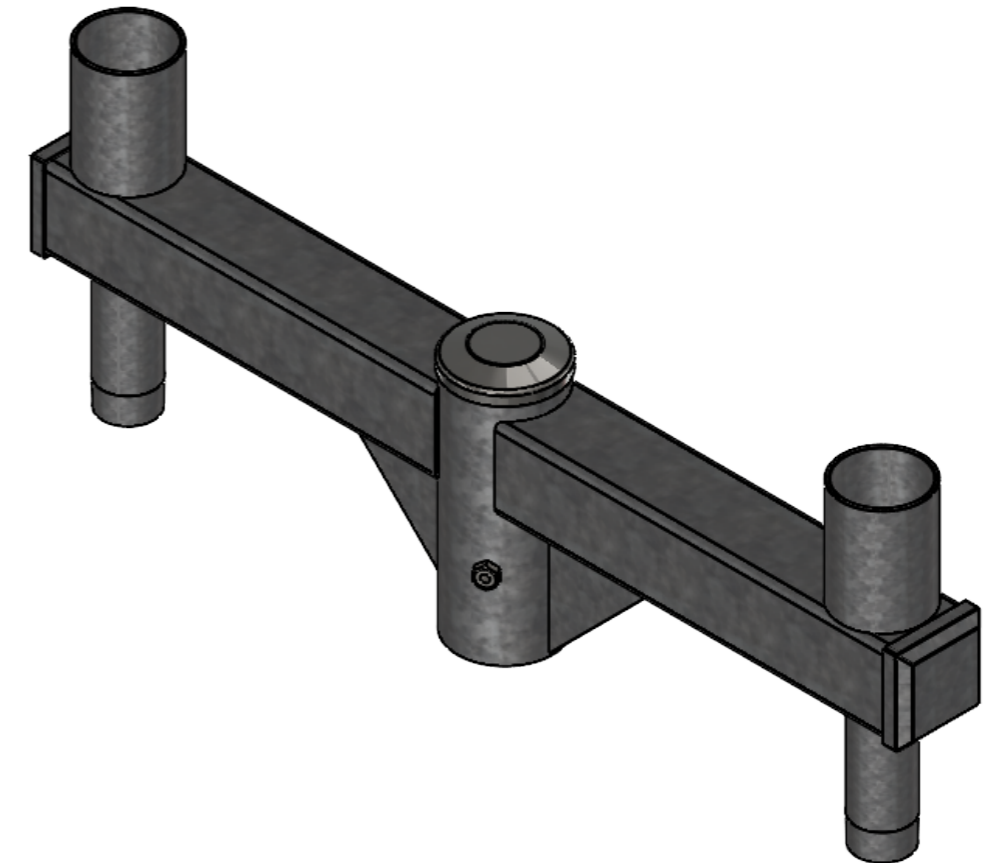
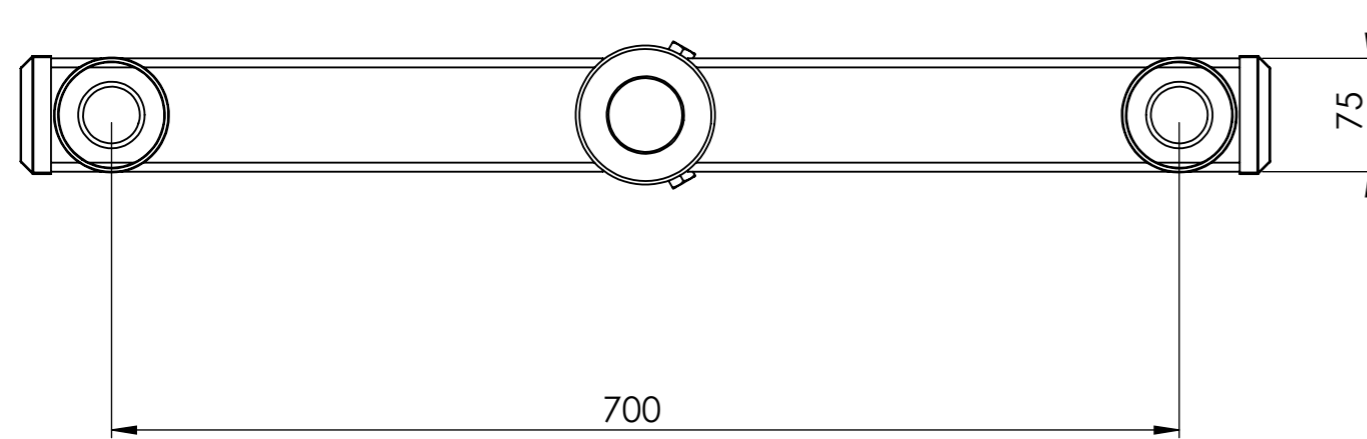
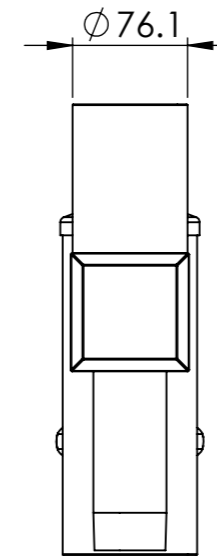
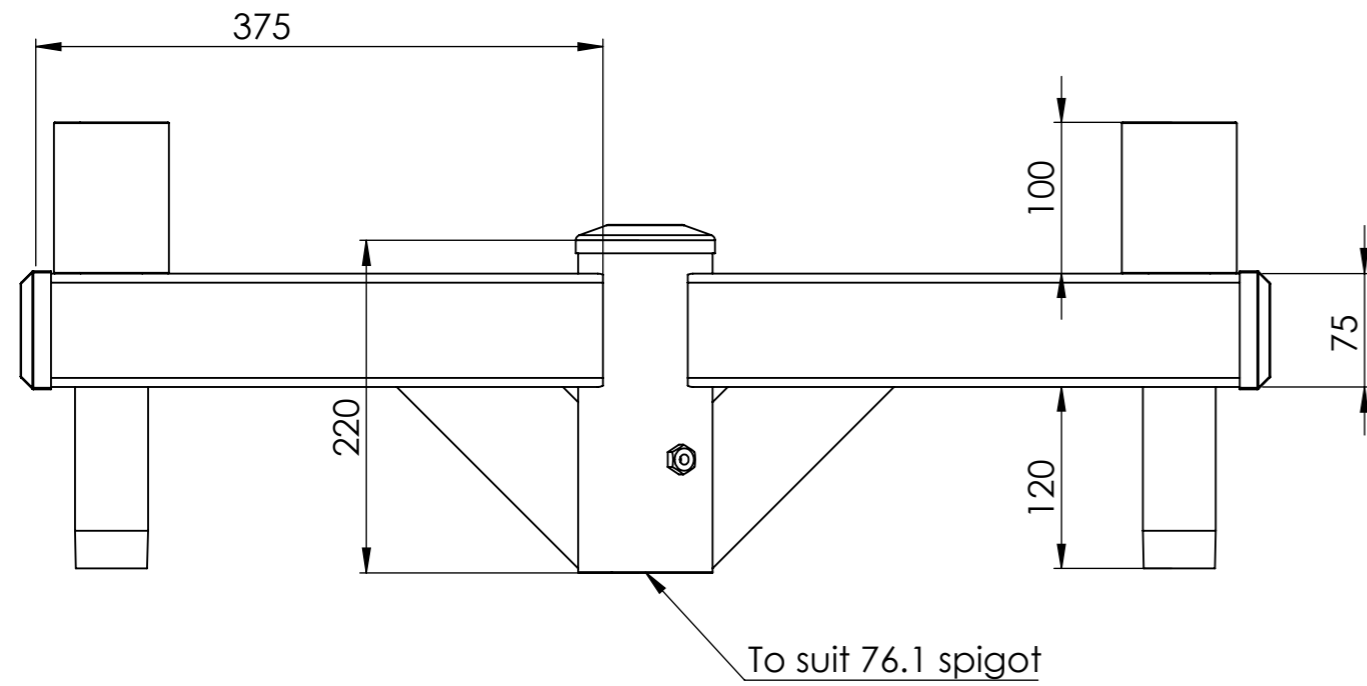

UNLESS OTHERWISE SPECIFIED: DIMENSIONS ARE IN MILLIMETERS	PROPRIETARY AND CONFIDENTIAL THE INFORMATION CONTAINED IN THIS DRAWING IS THE SOLE PROPERTY OF SEE SECURITY PTY LTD. ANY REPRODUCTION IN PART OR AS A WHOLE WITHOUT THE WRITTEN PERMISSION OF SEE SECURITY PTY LTD IS PROHIBITED.	DEBUR AND BREAK SHARP EDGES	DO NOT SCALE DRAWING	REVISION
FINISH:			 SEE SECURITY SECURITY & EQUIPMENT END OF LIFE	
NAME	SIGNATURE	DATE		
DRAWN	ADC	14/10/2016	DWG NO.	A3
MATERIAL:	Weight		SB00211A54	
Steel galvanised	10.5 kg		SCALE:1:5	SHEET 34 OF 84

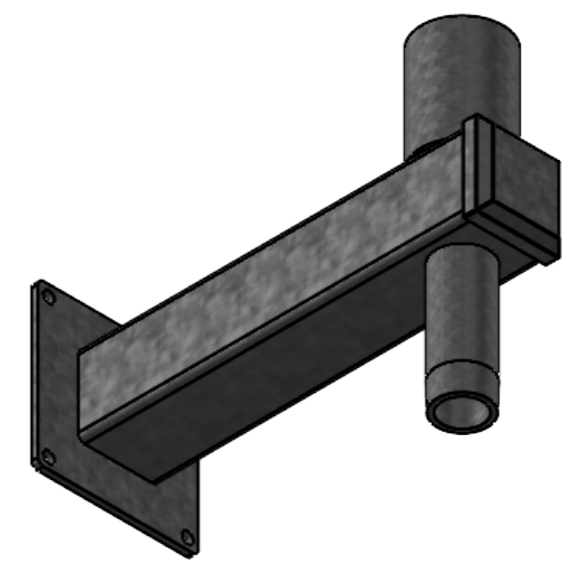
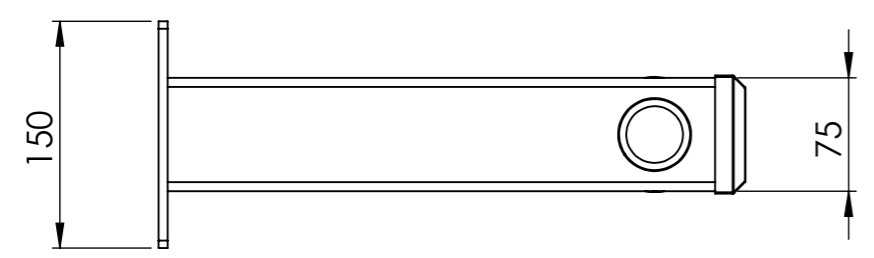
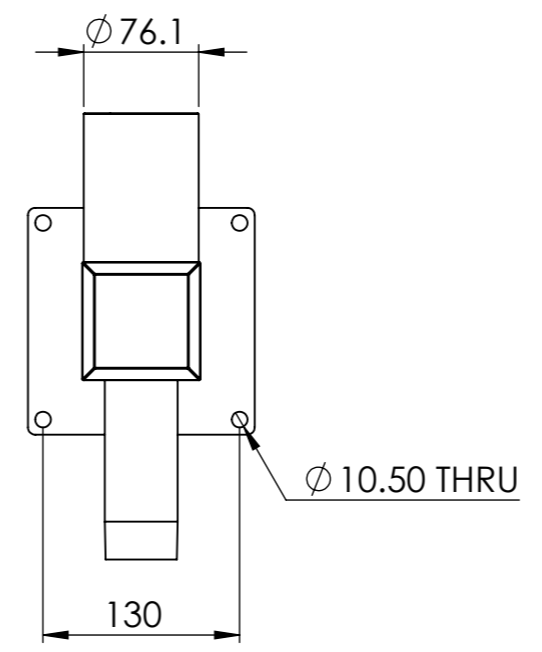
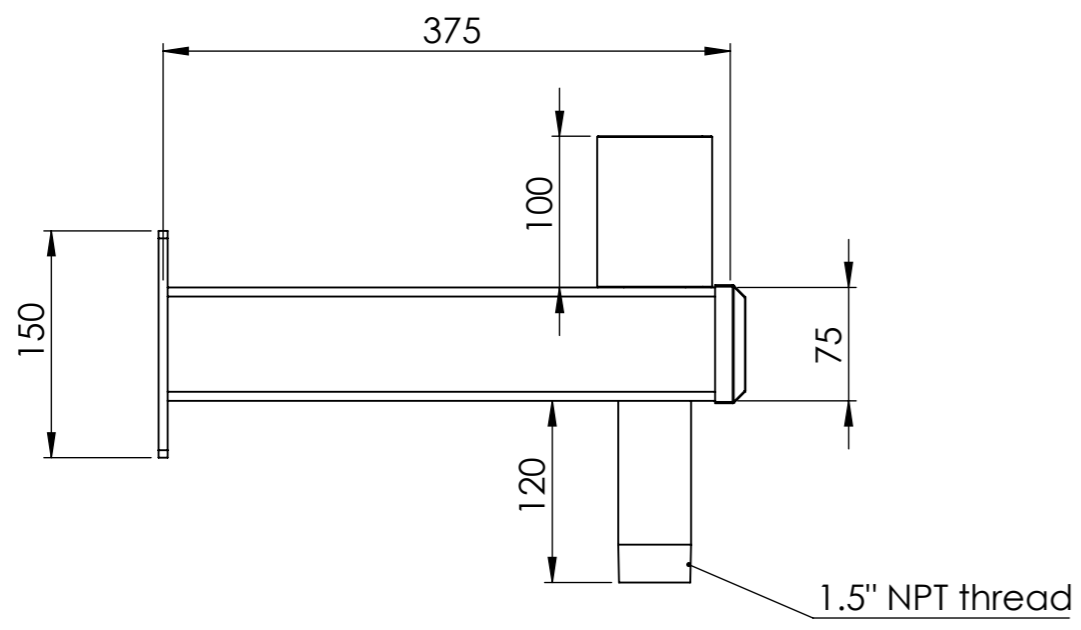

UNLESS OTHERWISE SPECIFIED: DIMENSIONS ARE IN MILLIMETERS	PROPRIETARY AND CONFIDENTIAL THE INFORMATION CONTAINED IN THIS DRAWING IS THE SOLE PROPERTY OF SEE SECURITY PTY LTD. ANY REPRODUCTION IN PART OR AS A WHOLE WITHOUT THE WRITTEN PERMISSION OF SEE SECURITY PTY LTD IS PROHIBITED.	DEBUR AND BREAK SHARP EDGES	DO NOT SCALE DRAWING	REVISION
FINISH:			 SEE SECURITY SECURITY & EQUIPMENT END OFFERS	
NAME	SIGNATURE	DATE		
DRAWN	ADC	14/10/2016	DWG NO.	A3
MATERIAL:	Weight		SB00211A60	
Steel galvanised	5kg		SCALE:1:5	SHEET 35 OF 84

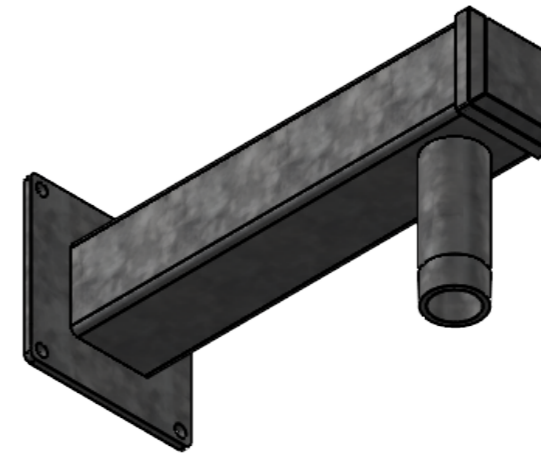
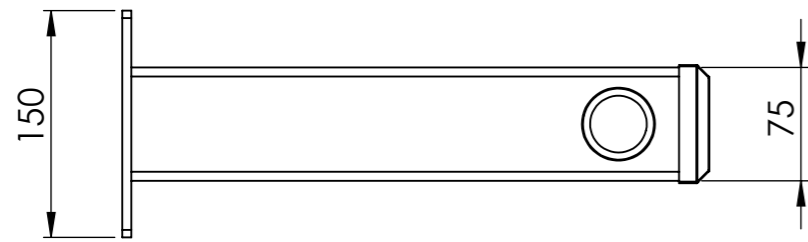
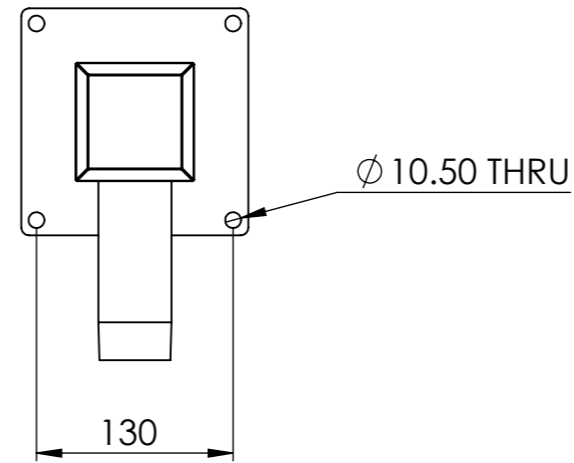
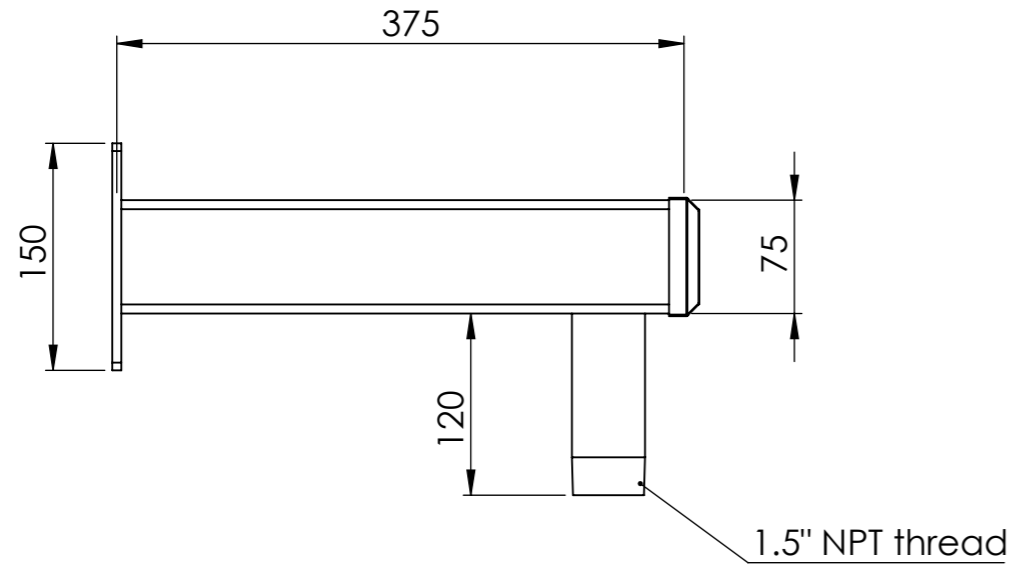

UNLESS OTHERWISE SPECIFIED: DIMENSIONS ARE IN MILLIMETERS	PROPRIETARY AND CONFIDENTIAL THE INFORMATION CONTAINED IN THIS DRAWING IS THE SOLE PROPERTY OF SEE SECURITY PTY LTD. ANY REPRODUCTION IN PART OR AS A WHOLE WITHOUT THE WRITTEN PERMISSION OF SEE SECURITY PTY LTD IS PROHIBITED.	DEBUR AND BREAK SHARP EDGES	DO NOT SCALE DRAWING	REVISION
FINISH:				
NAME	SIGNATURE	DATE		
DRAWN	ADC	14/10/2016	DWG NO.	A3
MATERIAL:	Weight		SB00211A62	
Steel galvanised	4.3kg		SCALE:1:5	SHEET 36 OF 84

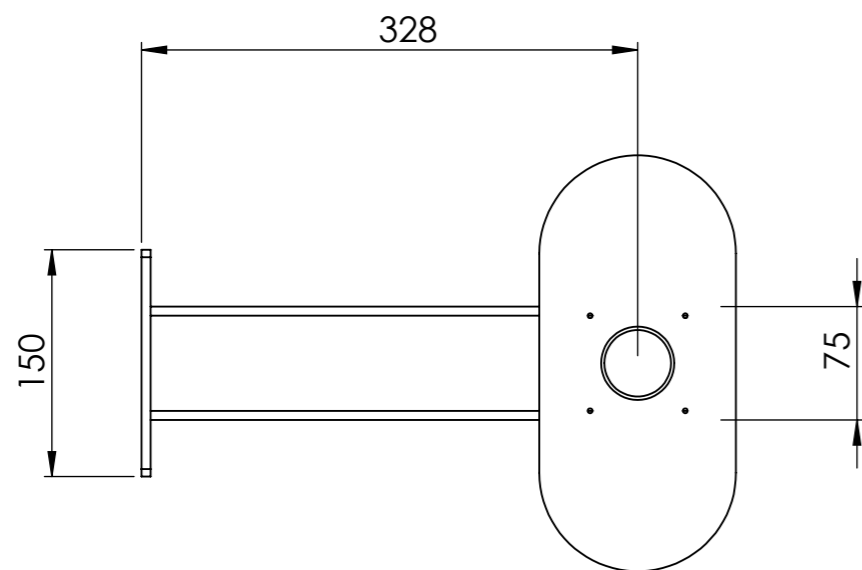
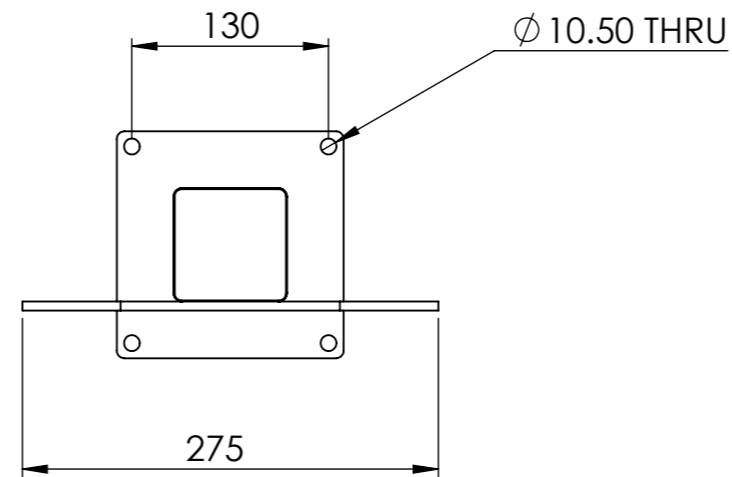
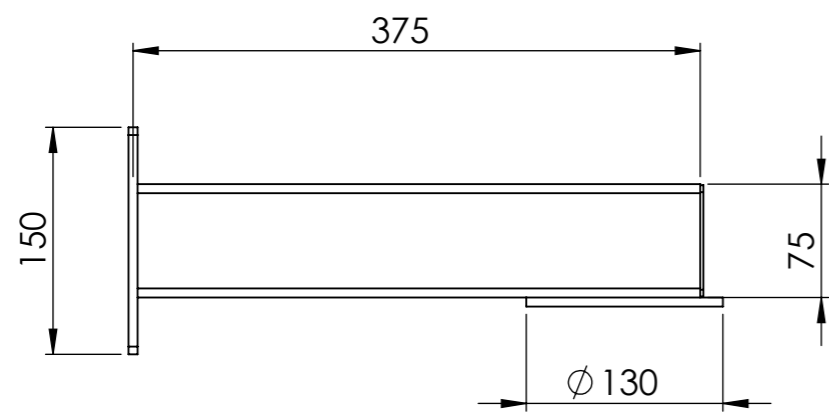

To suit Dual camera

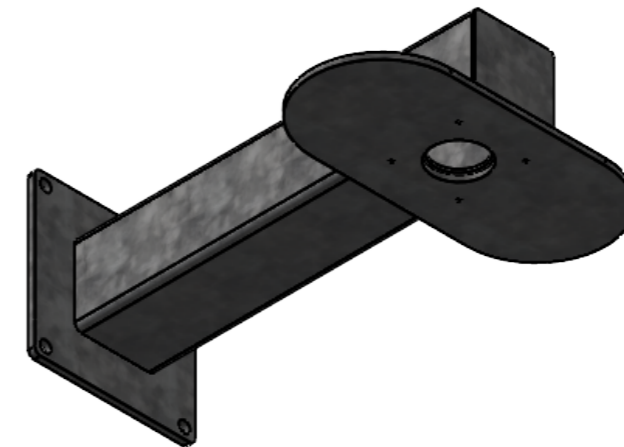

UNLESS OTHERWISE SPECIFIED: DIMENSIONS ARE IN MILLIMETERS	PROPRIETARY AND CONFIDENTIAL THE INFORMATION CONTAINED IN THIS DRAWING IS THE SOLE PROPERTY OF SEE SECURITY PTY LTD. ANY REPRODUCTION IN PART OR AS A WHOLE WITHOUT THE WRITTEN PERMISSION OF SEE SECURITY PTY LTD IS PROHIBITED.	DEBUR AND BREAK SHARP EDGES	DO NOT SCALE DRAWING	REVISION
FINISH:				
NAME	SIGNATURE	DATE		
DRAWN	ADC	14/10/2016		
MATERIAL:	Weight	DWG NO.		
Steel galvanised	4.7kg	SB00211A64		A3
		SCALE:1:5	SHEET 37 OF 84	

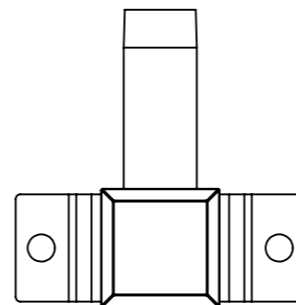
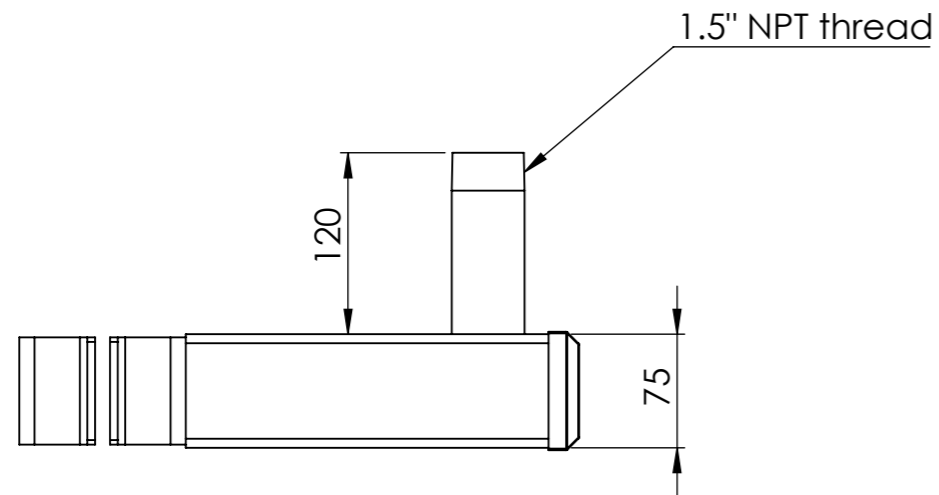
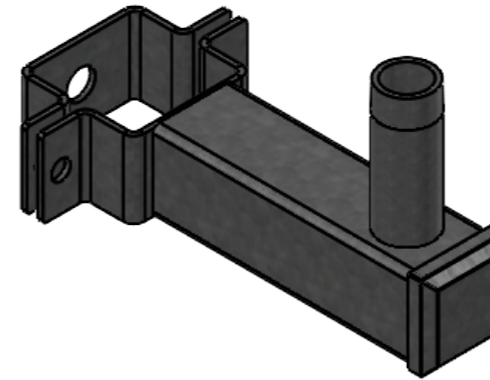
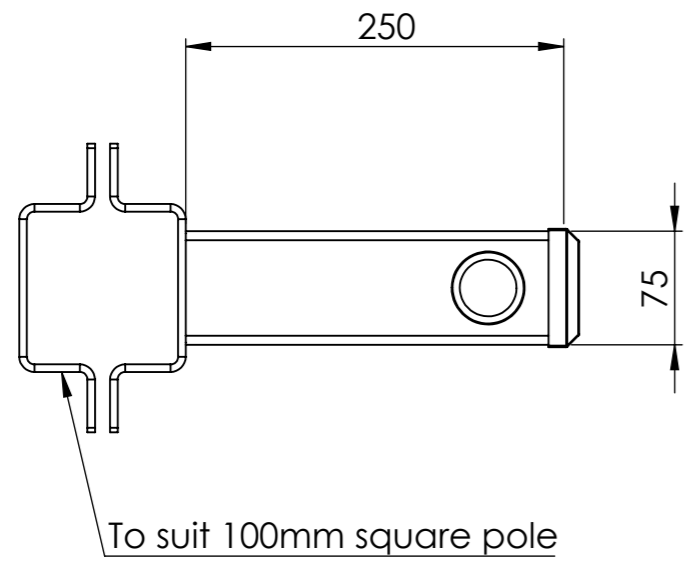

UNLESS OTHERWISE SPECIFIED: DIMENSIONS ARE IN MILLIMETERS	PROPRIETARY AND CONFIDENTIAL THE INFORMATION CONTAINED IN THIS DRAWING IS THE SOLE PROPERTY OF SEE SECURITY PTY LTD. ANY REPRODUCTION IN PART OR AS A WHOLE WITHOUT THE WRITTEN PERMISSION OF SEE SECURITY PTY LTD IS PROHIBITED.	DEBUR AND BREAK SHARP EDGES	DO NOT SCALE DRAWING	REVISION
FINISH:				
NAME	SIGNATURE	DATE		
DRAWN	ADC	14/10/2016		
MATERIAL:	Weight		DWG NO.	A3
Steel galvanised	4kg		SB00211A66	
			SCALE:1:5	SHEET 38 OF 84

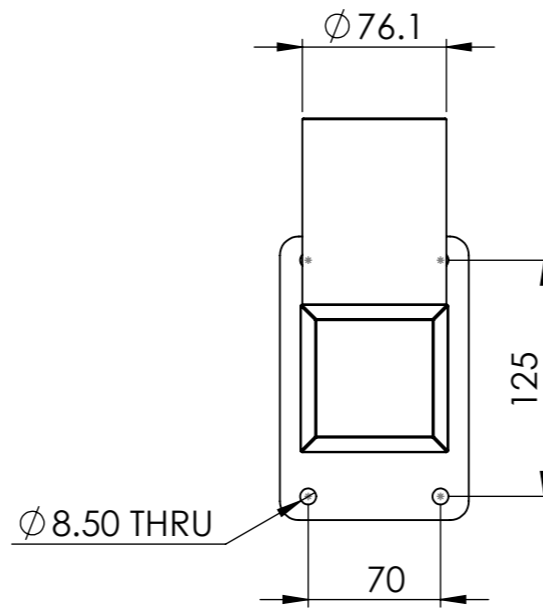
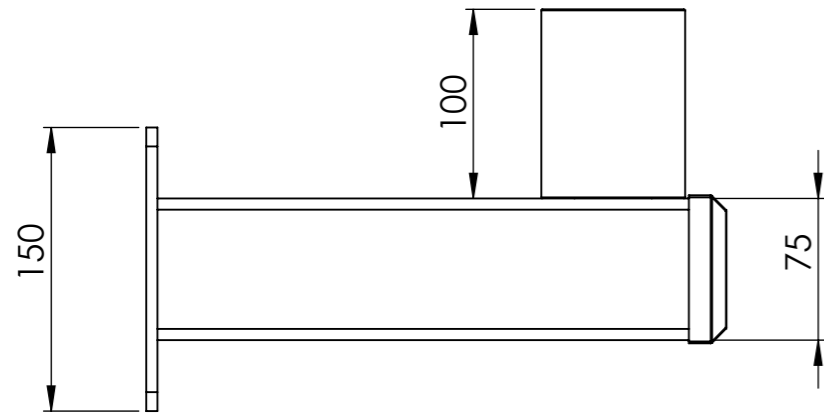
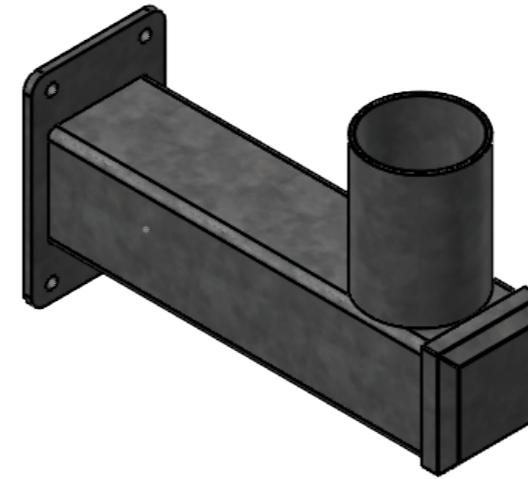
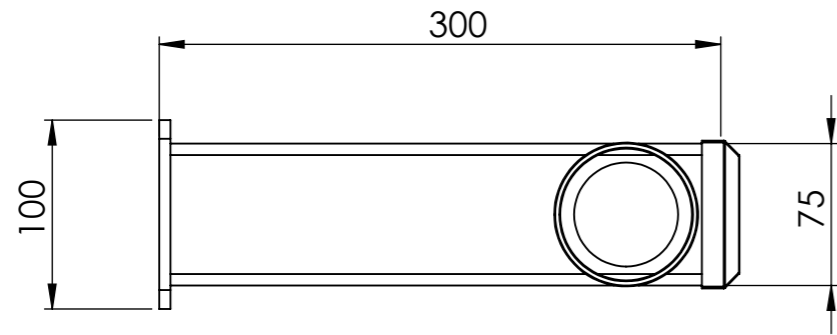

UNLESS OTHERWISE SPECIFIED: DIMENSIONS ARE IN MILLIMETERS	PROPRIETARY AND CONFIDENTIAL THE INFORMATION CONTAINED IN THIS DRAWING IS THE SOLE PROPERTY OF SEE SECURITY PTY LTD. ANY REPRODUCTION IN PART OR AS A WHOLE WITHOUT THE WRITTEN PERMISSION OF SEE SECURITY PTY LTD IS PROHIBITED.	DEBUR AND BREAK SHARP EDGES	DO NOT SCALE DRAWING	REVISION
FINISH:				
NAME	SIGNATURE	DATE		
DRAWN	ADC	14/10/2016		
MATERIAL:	Steel galvanised	Weight 3.3kg	DWG NO. SB00211A68	A3
			SCALE:1:5	SHEET 39 OF 84

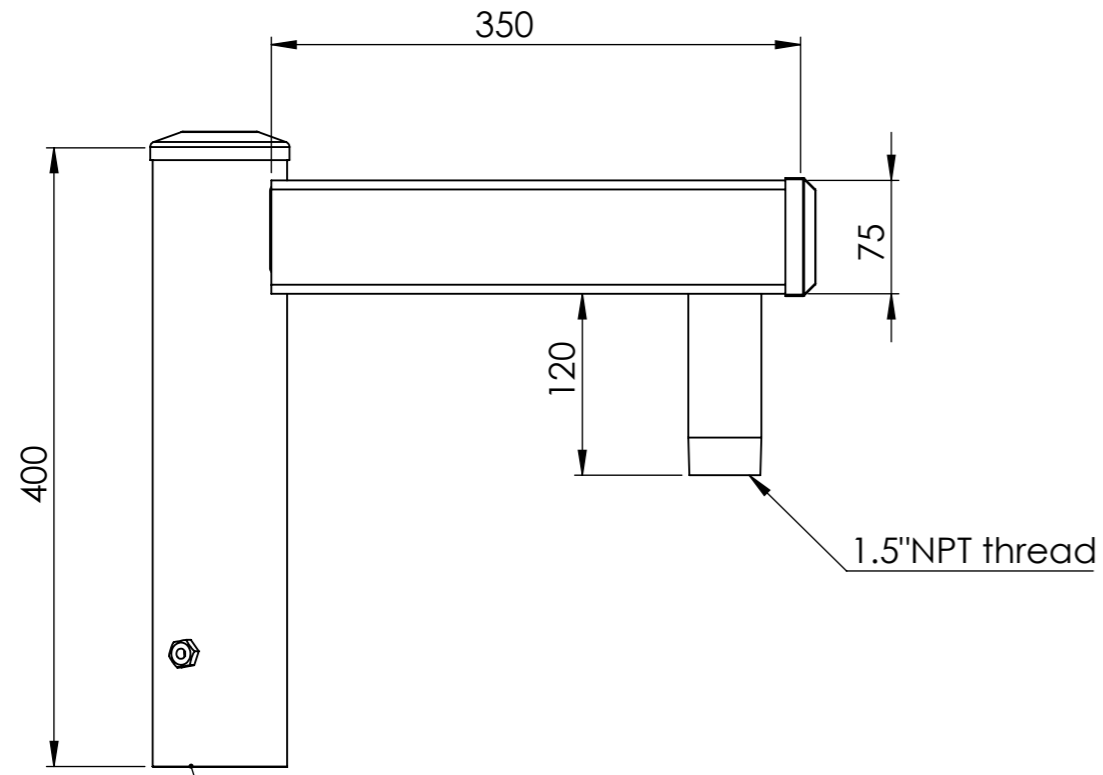

To suit 76.1 spigot

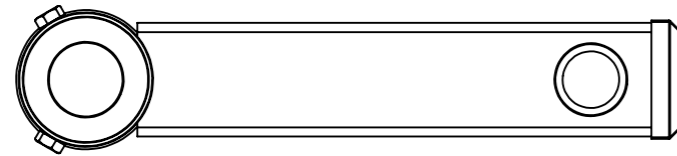
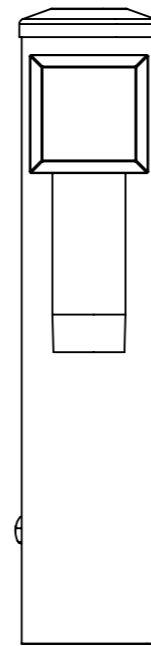

UNLESS OTHERWISE SPECIFIED: DIMENSIONS ARE IN MILLIMETERS	PROPRIETARY AND CONFIDENTIAL THE INFORMATION CONTAINED IN THIS DRAWING IS THE SOLE PROPERTY OF SEE SECURITY PTY LTD. ANY REPRODUCTION IN PART OR AS A WHOLE WITHOUT THE WRITTEN PERMISSION OF SEE SECURITY PTY LTD IS PROHIBITED.	DEBUR AND BREAK SHARP EDGES	DO NOT SCALE DRAWING	REVISION
FINISH:				
NAME	SIGNATURE	DATE		
DRAWN	ADC	14/10/2016		
MATERIAL:	Weight	DWG NO.		A3
Steel galvanised	6.2kg	SB00211A70		
		SCALE:1:5	SHEET 40 OF 84	

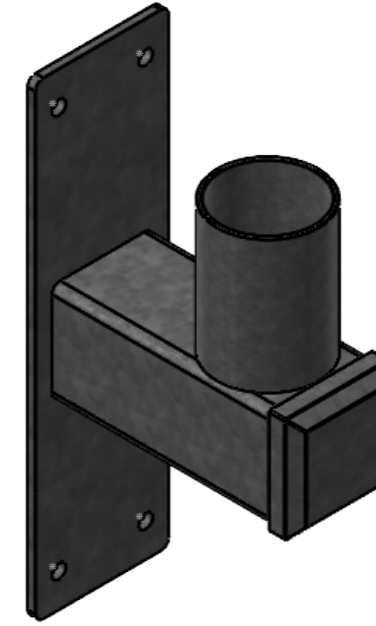
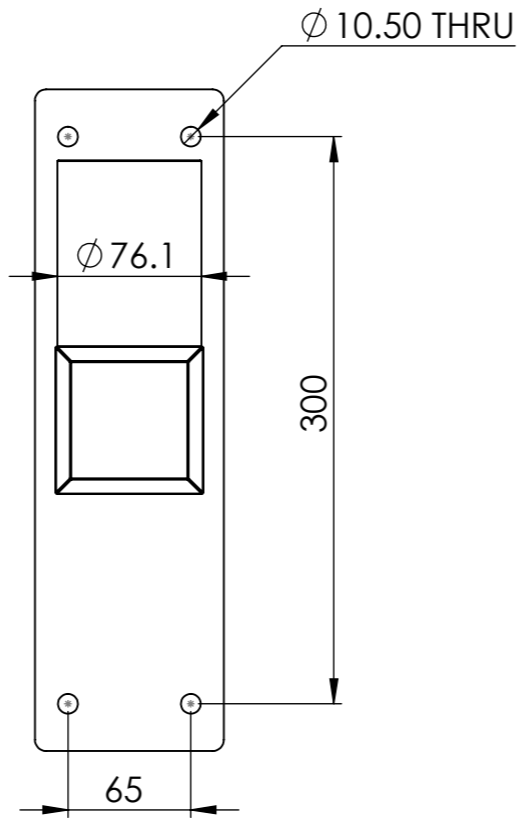
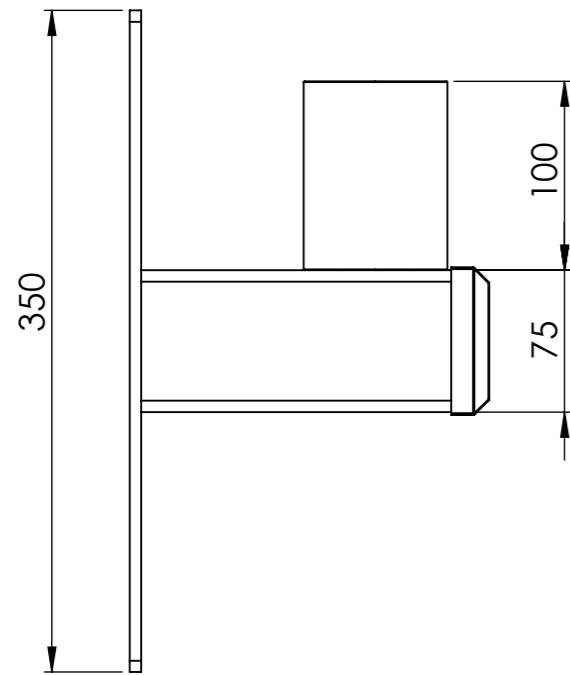
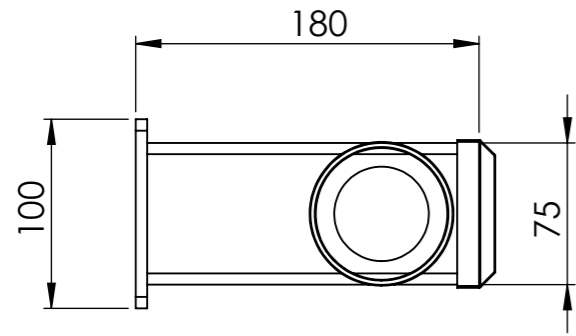

UNLESS OTHERWISE SPECIFIED: DIMENSIONS ARE IN MILLIMETERS	PROPRIETARY AND CONFIDENTIAL THE INFORMATION CONTAINED IN THIS DRAWING IS THE SOLE PROPERTY OF SEE SECURITY PTY LTD. ANY REPRODUCTION IN PART OR AS A WHOLE WITHOUT THE WRITTEN PERMISSION OF SEE SECURITY PTY LTD IS PROHIBITED.	DEBUR AND BREAK SHARP EDGES	DO NOT SCALE DRAWING	REVISION
FINISH:			 SEE SECURITY SECURITY & EQUIPMENT END OF LIFE	
NAME	SIGNATURE	DATE		
DRAWN	ADC	14/10/2016	DWG NO.	A3
MATERIAL:	Weight	SB00211A72		
Steel galvanised	3.5 kg	SCALE:1:5	SHEET 41 OF 84	

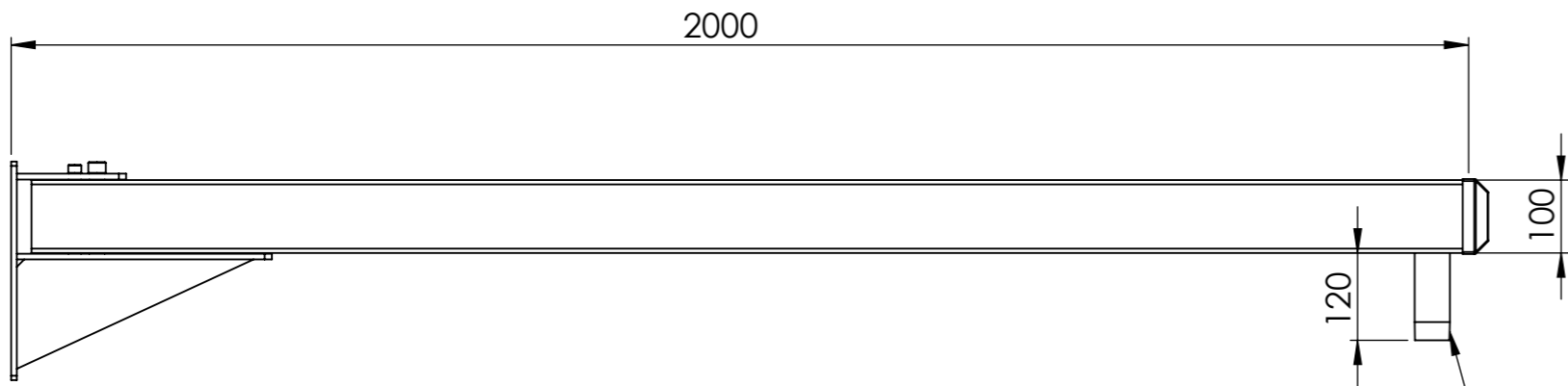
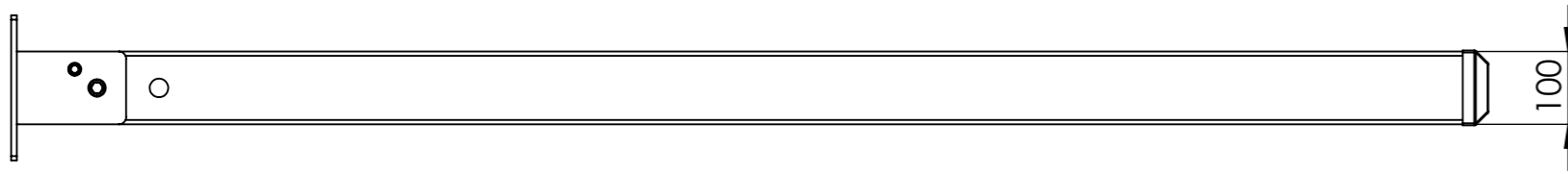

1.5"NPT thread

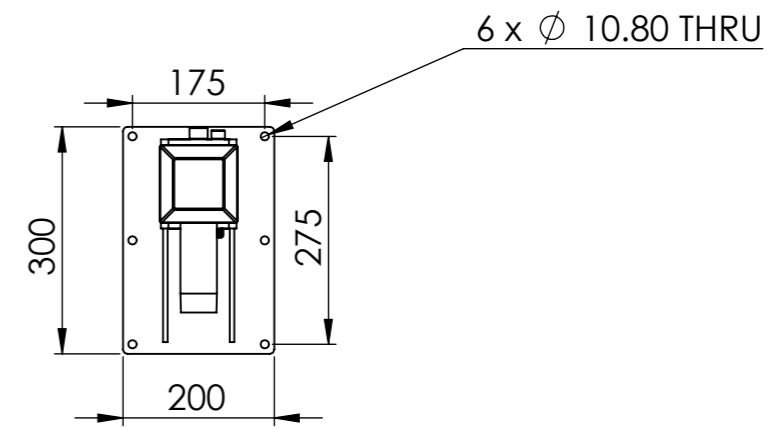

UNLESS OTHERWISE SPECIFIED: DIMENSIONS ARE IN MILLIMETERS		PROPRIETARY AND CONFIDENTIAL THE INFORMATION CONTAINED IN THIS DRAWING IS THE SOLE PROPERTY OF SEE SECURITY PTY LTD. ANY REPRODUCTION IN PART OR AS A WHOLE WITHOUT THE WRITTEN PERMISSION OF SEE SECURITY PTY LTD IS PROHIBITED.		DEBUR AND BREAK SHARP EDGES		DO NOT SCALE DRAWING		REVISION	
FINISH:		NAME		SIGNATURE		DATE		 SEE SECURITY SECURITY & EQUIPMENT END OFFERS	
DRAWN		ADC		14/10/2016		DWG NO.			
MATERIAL:				Weight		SB00211A76		SCALE:1:5	
Steel galvanised				28kg		SHEET 42 OF 84			

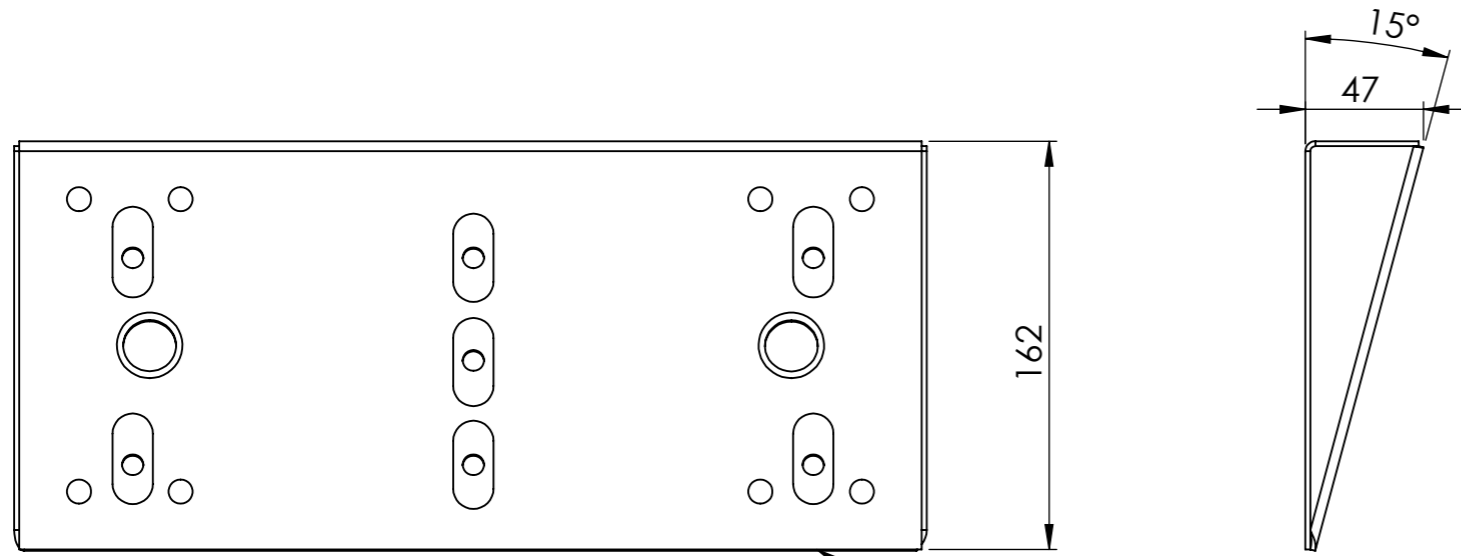

To suit SMW5 wedge housing

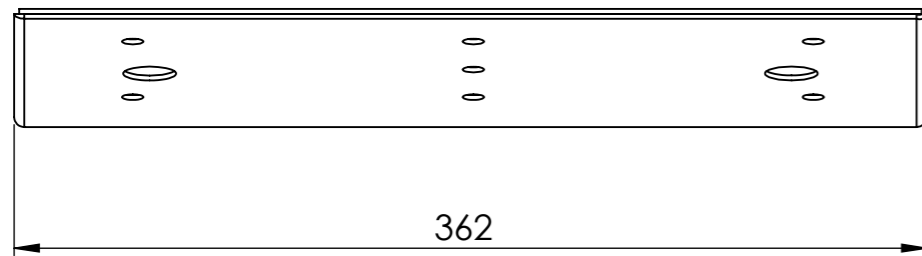
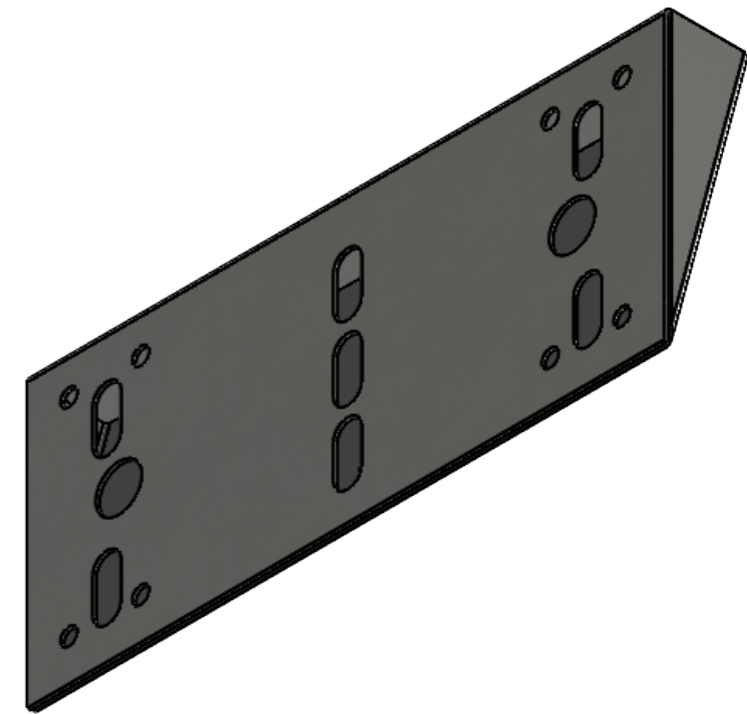

UNLESS OTHERWISE SPECIFIED: DIMENSIONS ARE IN MILLIMETERS	PROPRIETARY AND CONFIDENTIAL THE INFORMATION CONTAINED IN THIS DRAWING IS THE SOLE PROPERTY OF SEE SECURITY PTY LTD. ANY REPRODUCTION IN PART OR AS A WHOLE WITHOUT THE WRITTEN PERMISSION OF SEE SECURITY PTY LTD IS PROHIBITED.	DEBUR AND BREAK SHARP EDGES	DO NOT SCALE DRAWING	REVISION
FINISH:				
NAME	SIGNATURE	DATE		
DRAWN	ADC	14/10/2016	DWG NO.	A3
MATERIAL:	Weight		SB00217A05	
Steel powder coated	2kg		SCALE:1:5	SHEET 43 OF 84

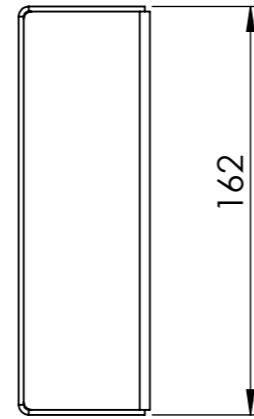
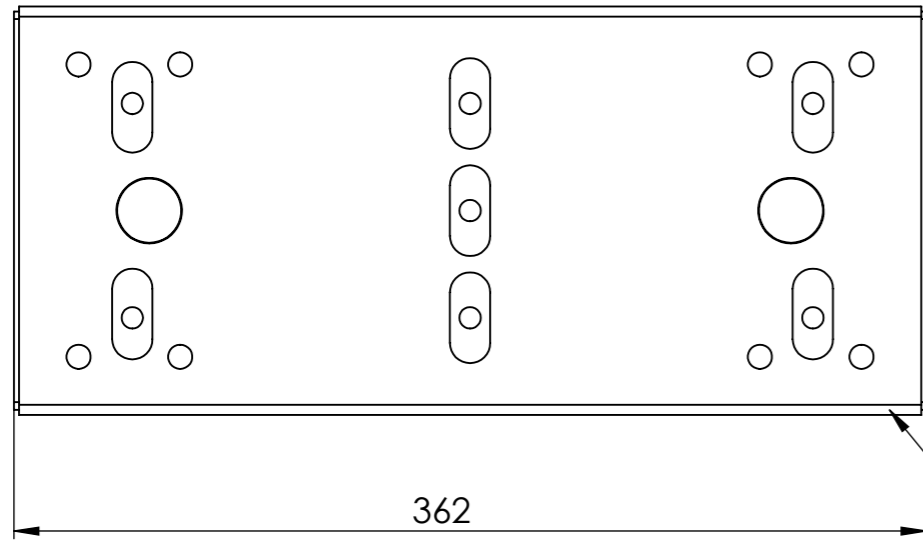

To suit SMW5 wedge housing

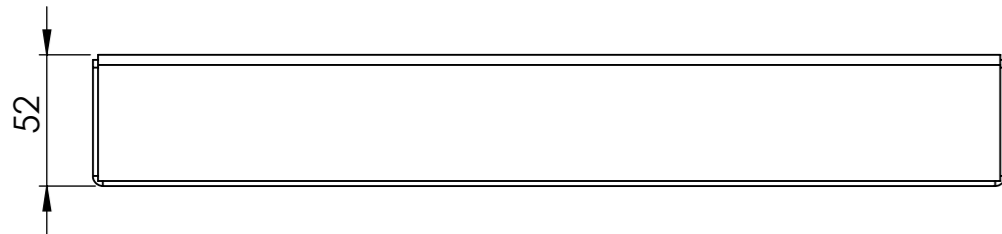
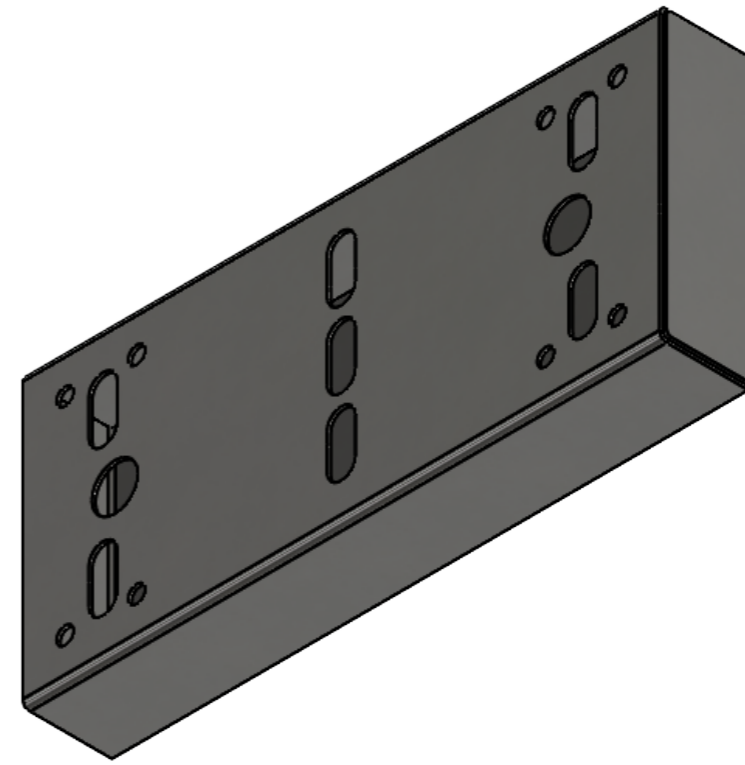

UNLESS OTHERWISE SPECIFIED: DIMENSIONS ARE IN MILLIMETERS		PROPRIETARY AND CONFIDENTIAL THE INFORMATION CONTAINED IN THIS DRAWING IS THE SOLE PROPERTY OF SEE SECURITY PTY LTD. ANY REPRODUCTION IN PART OR AS A WHOLE WITHOUT THE WRITTEN PERMISSION OF SEE SECURITY PTY LTD IS PROHIBITED.		DEBUR AND BREAK SHARP EDGES	DO NOT SCALE DRAWING	REVISION
FINISH:		NAME SIGNATURE DATE				
DRAWN ADC		14/10/2016				
MATERIAL: Steel powder coated		Weight 2.5kg		DWG NO. SB00217A06		A3
				SCALE:1:5		SHEET 44 OF 84

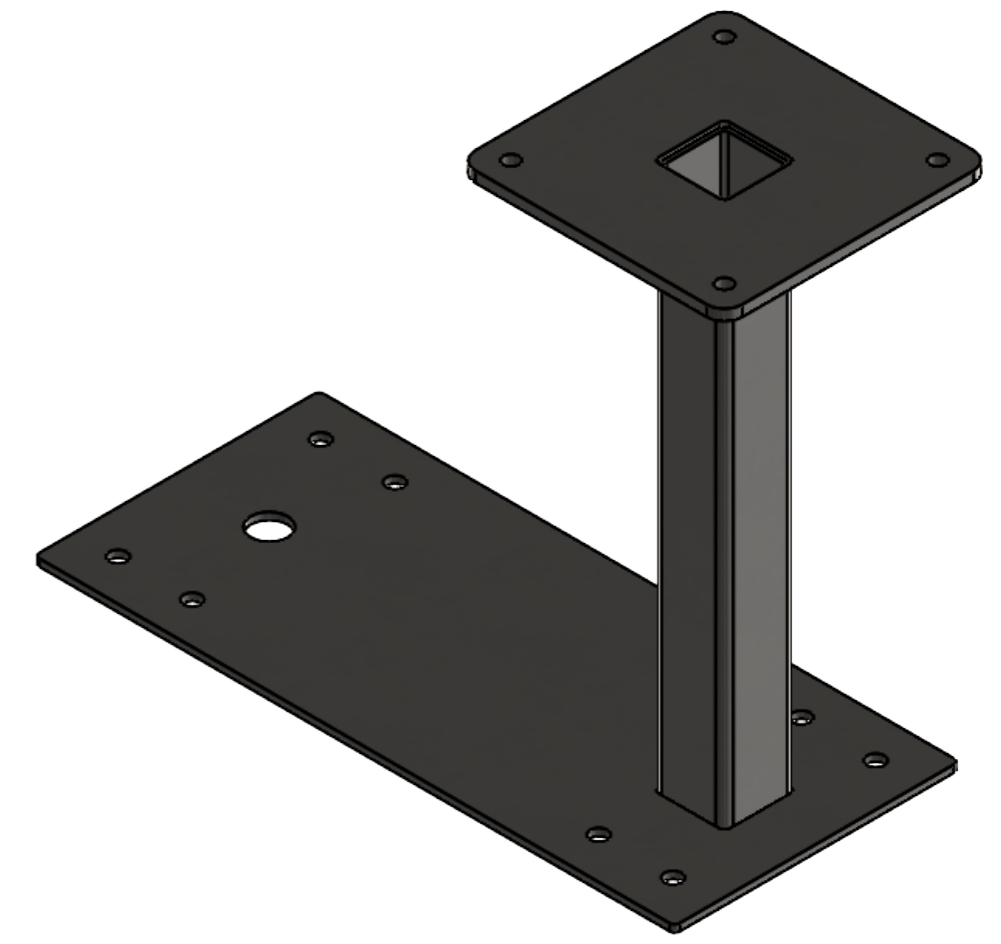
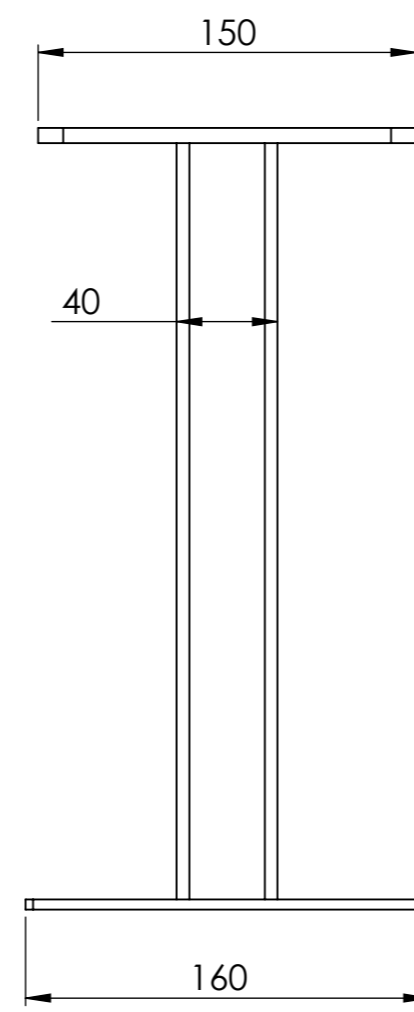
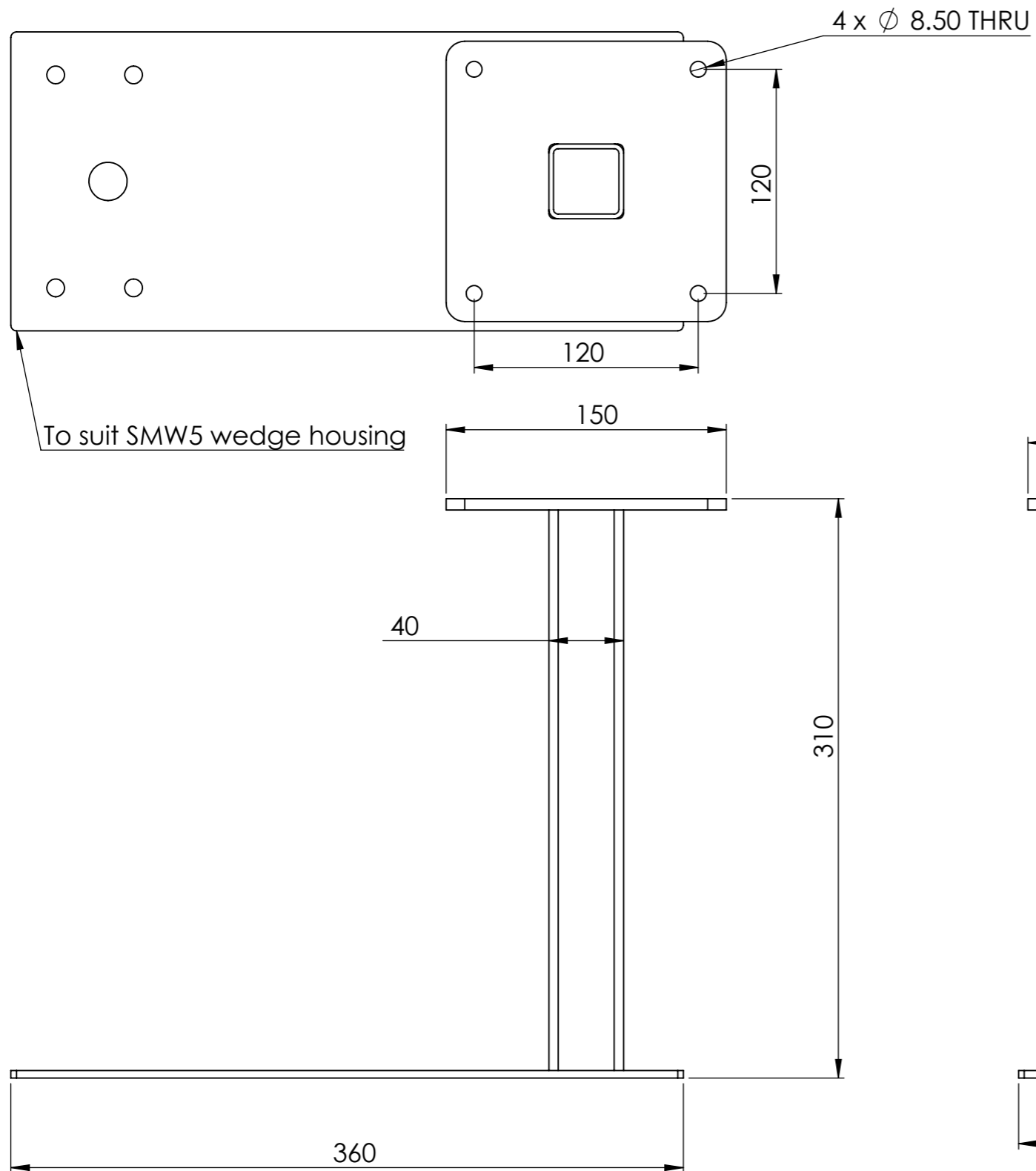

UNLESS OTHERWISE SPECIFIED: DIMENSIONS ARE IN MILLIMETERS	PROPRIETARY AND CONFIDENTIAL THE INFORMATION CONTAINED IN THIS DRAWING IS THE SOLE PROPERTY OF SEE SECURITY PTY LTD. ANY REPRODUCTION IN PART OR AS A WHOLE WITHOUT THE WRITTEN PERMISSION OF SEE SECURITY PTY LTD IS PROHIBITED.	DEBUR AND BREAK SHARP EDGES	DO NOT SCALE DRAWING	REVISION
FINISH:				
NAME	SIGNATURE	DATE		
DRAWN	ADC	14/10/2016	DWG NO.	A3
MATERIAL:	Weight		SB00217A07	
Steel galvanised	1.5kg		SCALE:1:5	SHEET 45 OF 84

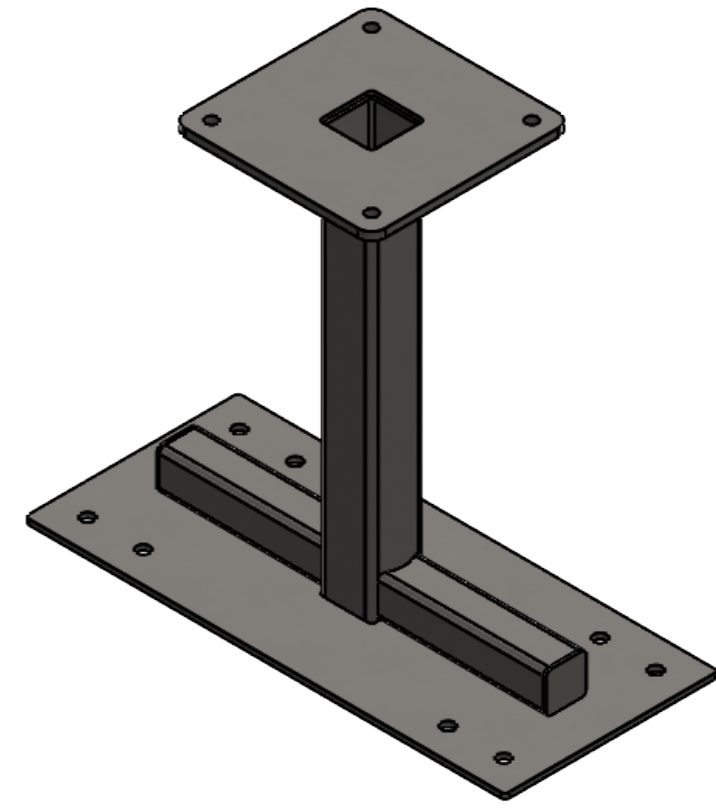
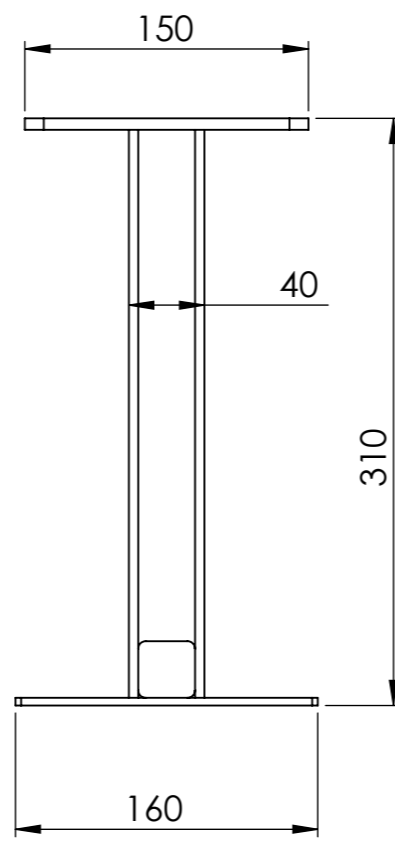
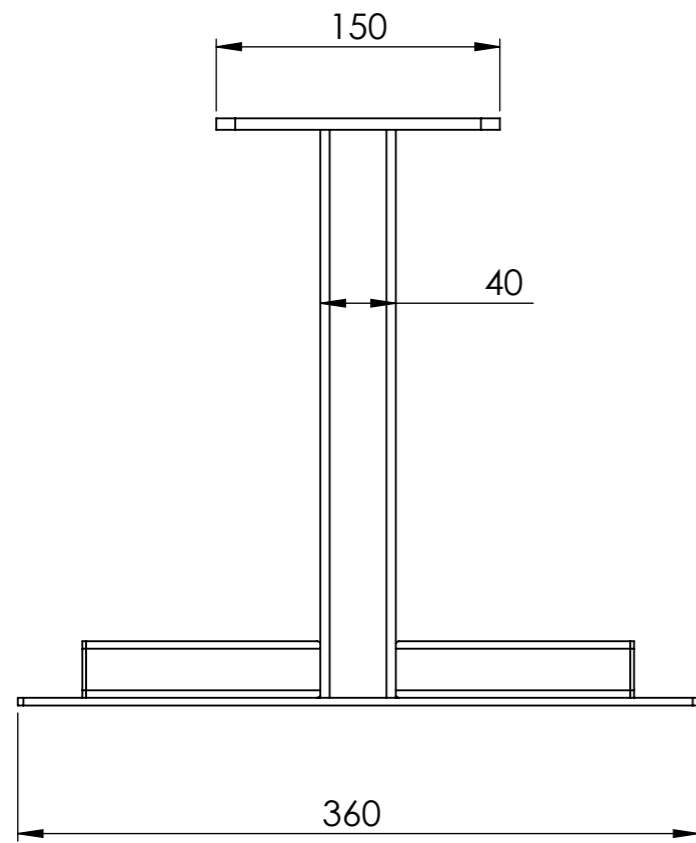
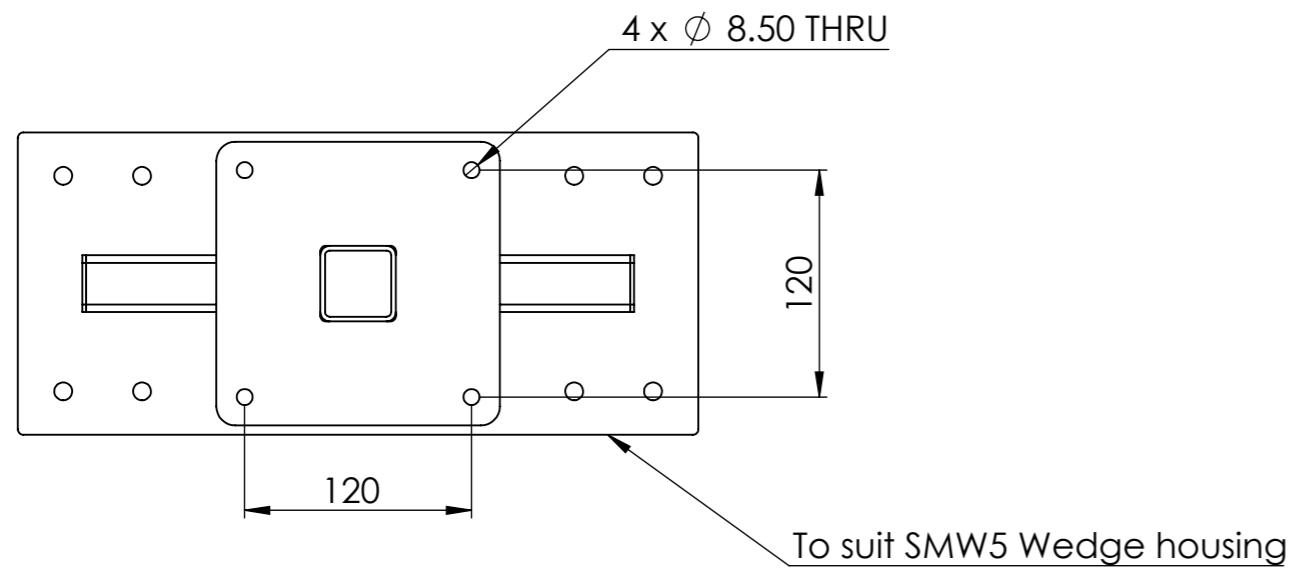

UNLESS OTHERWISE SPECIFIED: DIMENSIONS ARE IN MILLIMETERS	PROPRIETARY AND CONFIDENTIAL THE INFORMATION CONTAINED IN THIS DRAWING IS THE SOLE PROPERTY OF SEE SECURITY PTY LTD. ANY REPRODUCTION IN PART OR AS A WHOLE WITHOUT THE WRITTEN PERMISSION OF SEE SECURITY PTY LTD IS PROHIBITED.	DEBUR AND BREAK SHARP EDGES	DO NOT SCALE DRAWING	REVISION
FINISH:				
NAME	SIGNATURE	DATE		
DRAWN	ADC	14/10/2016	DWG NO.	A3
MATERIAL:	Weight			
Steel Powder coated	4kg		SB00217A08	
			SCALE:1:5	SHEET 46 OF 84

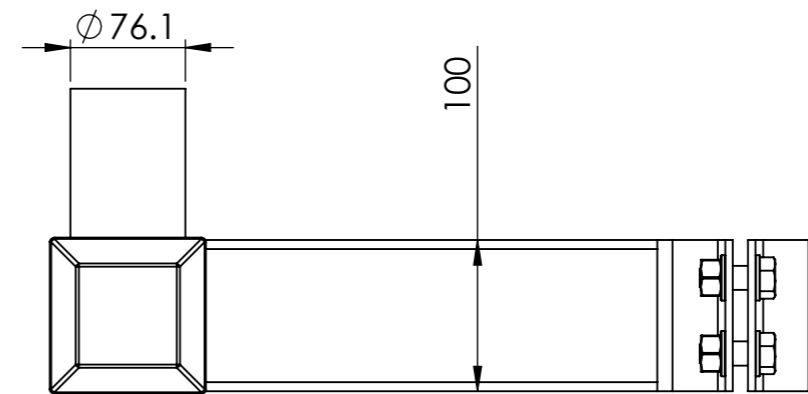
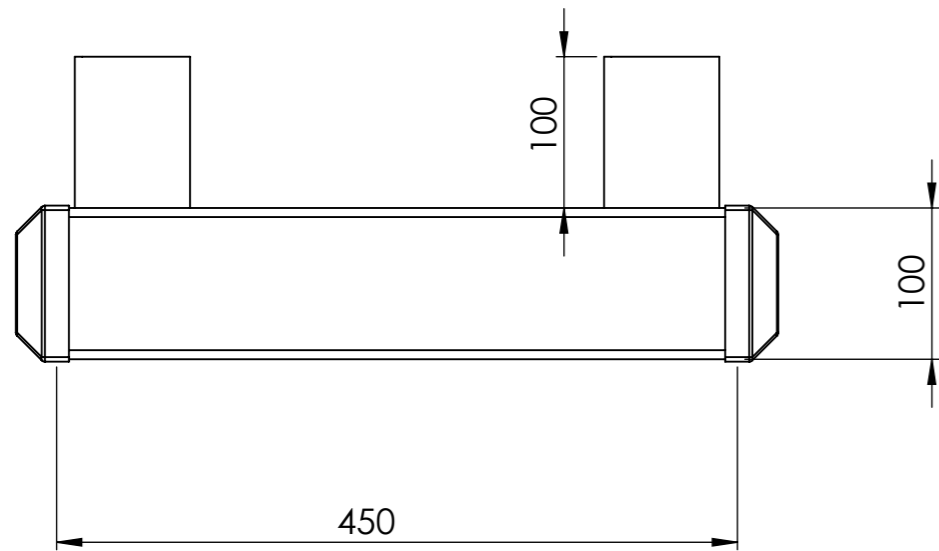
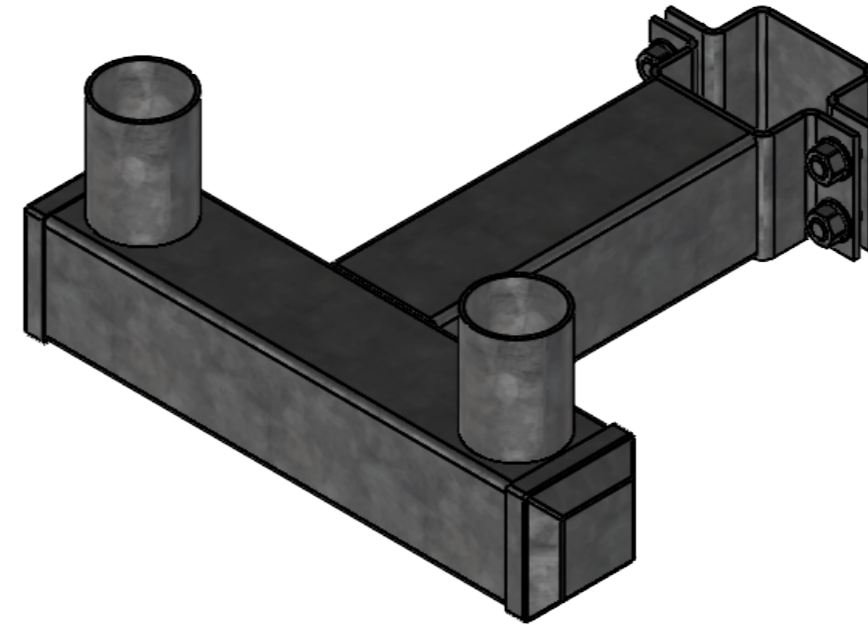
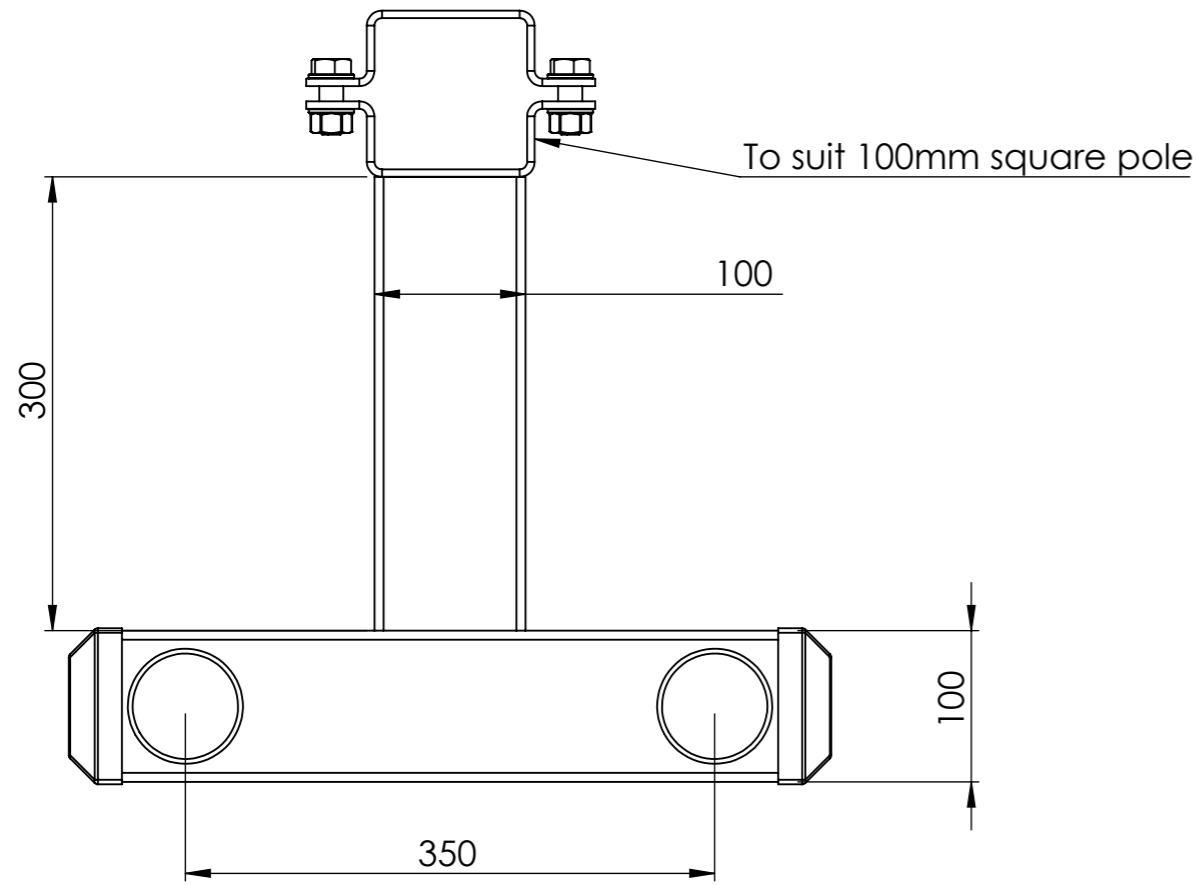

UNLESS OTHERWISE SPECIFIED: DIMENSIONS ARE IN MILLIMETERS	PROPRIETARY AND CONFIDENTIAL THE INFORMATION CONTAINED IN THIS DRAWING IS THE SOLE PROPERTY OF SEE SECURITY PTY LTD. ANY REPRODUCTION IN PART OR AS A WHOLE WITHOUT THE WRITTEN PERMISSION OF SEE SECURITY PTY LTD IS PROHIBITED.	DEBUR AND BREAK SHARP EDGES	DO NOT SCALE DRAWING	REVISION
FINISH:			 SEE SECURITY SECURITY & EQUIPMENT END OFFERS	
NAME	SIGNATURE	DATE		
DRAWN	ADC	14/10/2016	DWG NO.	A3
MATERIAL:	Weight		SB00217A10	
Steel galvanised	11kg		SCALE:1:5	SHEET 47 OF 84

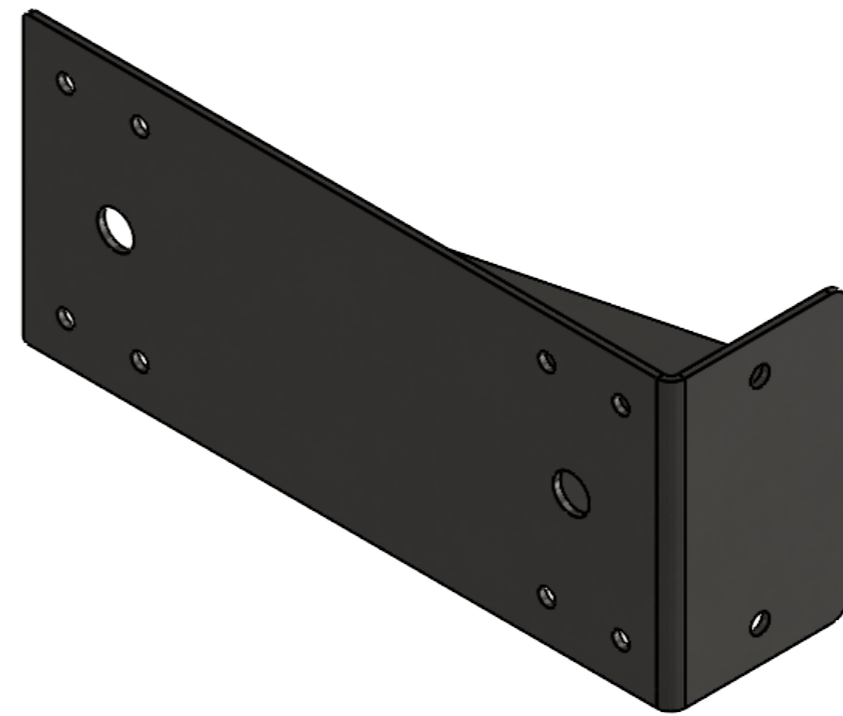
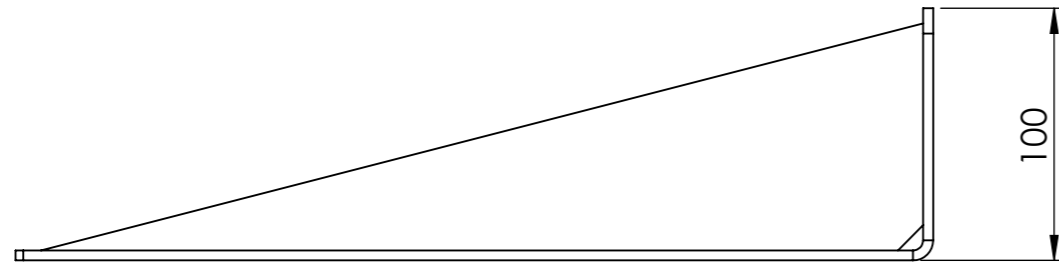

To suit SMW5 Wedge housing

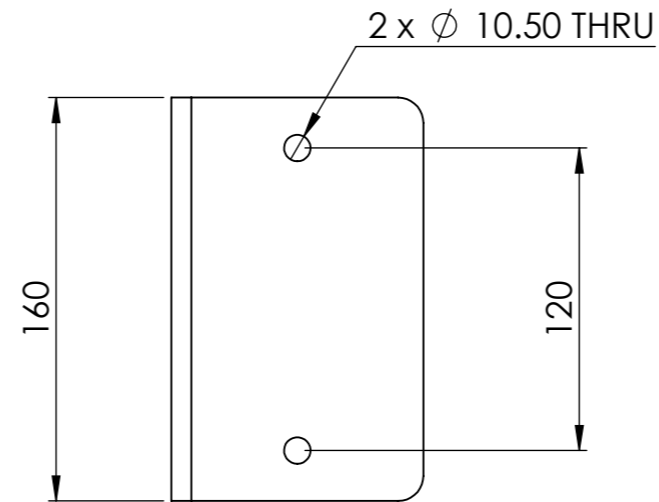

UNLESS OTHERWISE SPECIFIED: DIMENSIONS ARE IN MILLIMETERS	PROPRIETARY AND CONFIDENTIAL THE INFORMATION CONTAINED IN THIS DRAWING IS THE SOLE PROPERTY OF SEE SECURITY PTY LTD. ANY REPRODUCTION IN PART OR AS A WHOLE WITHOUT THE WRITTEN PERMISSION OF SEE SECURITY PTY LTD IS PROHIBITED.	DEBUR AND BREAK SHARP EDGES	DO NOT SCALE DRAWING	REVISION
FINISH:			 SEE SECURITY SECURITY & EQUIPMENT END. OFFERS	
NAME	SIGNATURE	DATE		
DRAWN	ADC	14/10/2016	DWG NO.	A3
MATERIAL:	Weight		SB00221A03	
Steel Powder coated	3.3kg		SCALE:1:5	SHEET 48 OF 84

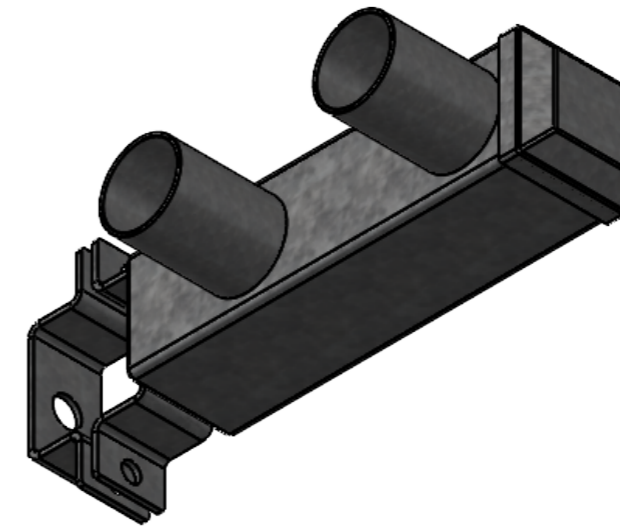
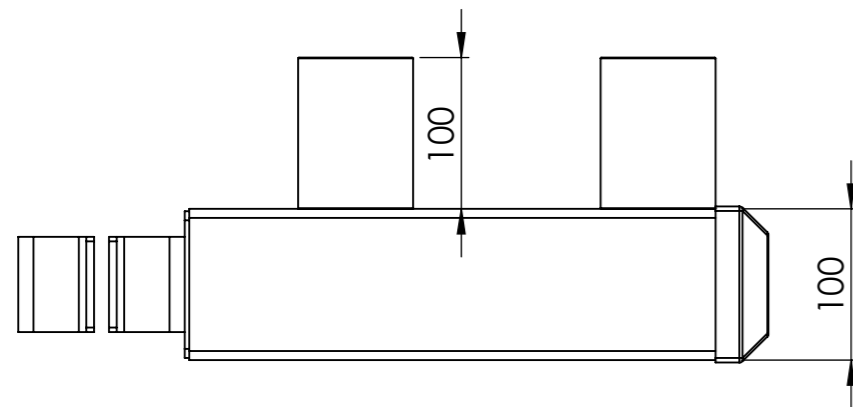
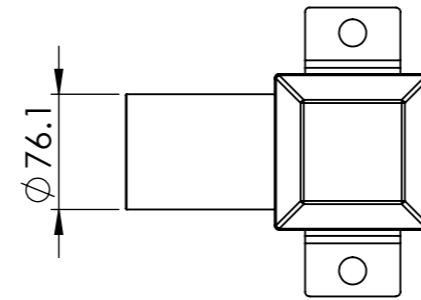
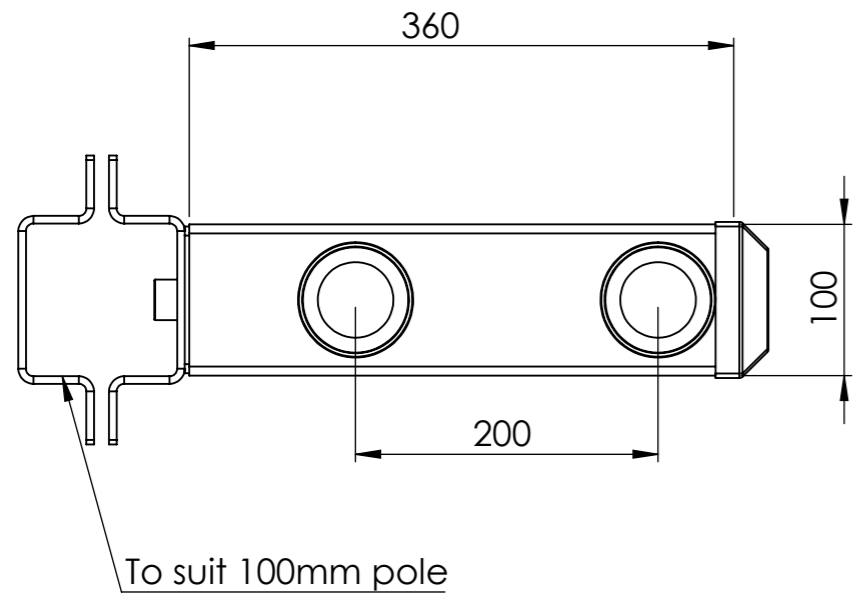

UNLESS OTHERWISE SPECIFIED: DIMENSIONS ARE IN MILLIMETERS	PROPRIETARY AND CONFIDENTIAL THE INFORMATION CONTAINED IN THIS DRAWING IS THE SOLE PROPERTY OF SEE SECURITY PTY LTD. ANY REPRODUCTION IN PART OR AS A WHOLE WITHOUT THE WRITTEN PERMISSION OF SEE SECURITY PTY LTD IS PROHIBITED.	DEBUR AND BREAK SHARP EDGES	DO NOT SCALE DRAWING	REVISION
FINISH:				
NAME	SIGNATURE	DATE		
DRAWN	ADC	14/10/2016		
MATERIAL:	Weight		DWG NO.	A3
Steel Galvanised	6kg		SB00248A02	
			SCALE:1:5	SHEET 49 OF 84

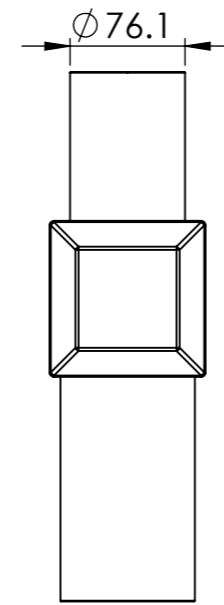
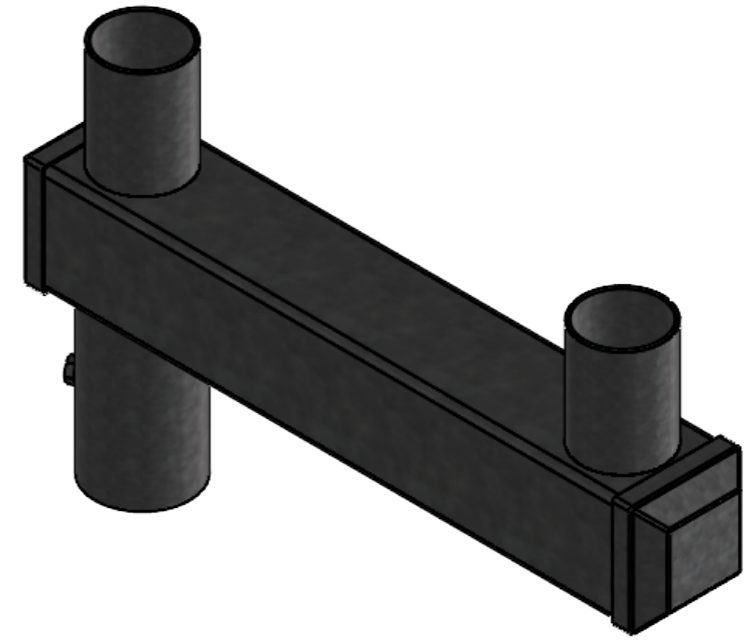
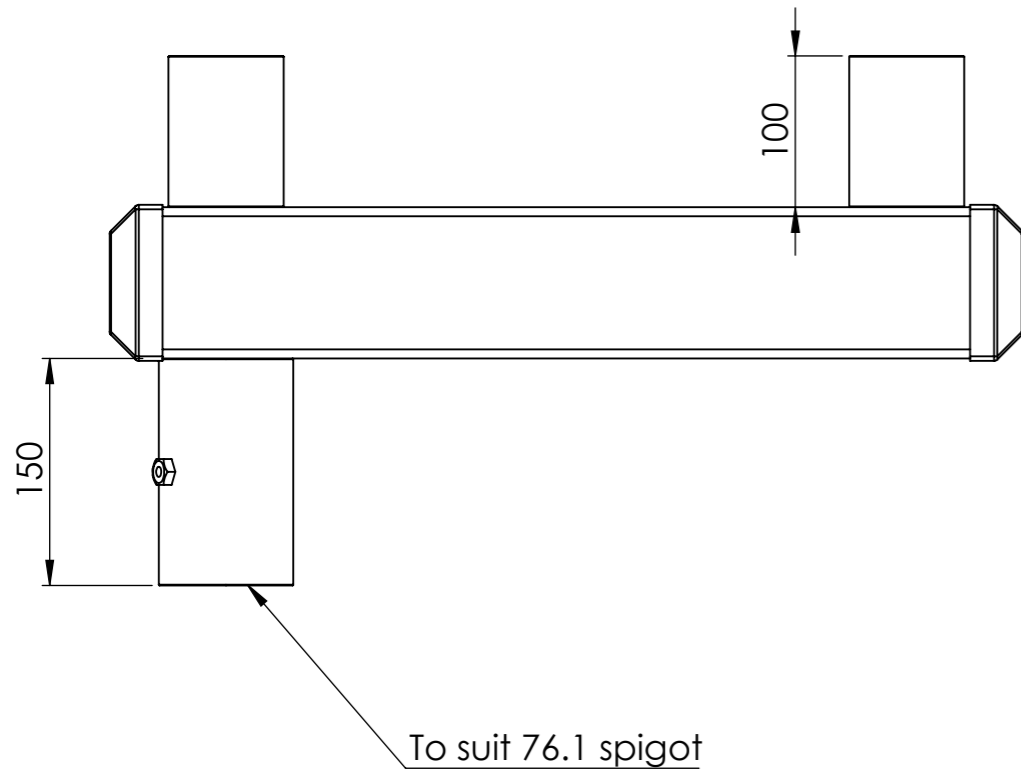
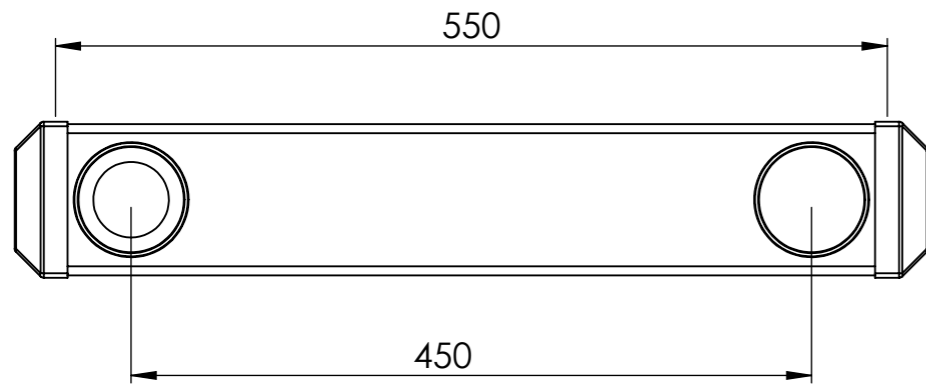

UNLESS OTHERWISE SPECIFIED: DIMENSIONS ARE IN MILLIMETERS	PROPRIETARY AND CONFIDENTIAL THE INFORMATION CONTAINED IN THIS DRAWING IS THE SOLE PROPERTY OF SEE SECURITY PTY LTD. ANY REPRODUCTION IN PART OR AS A WHOLE WITHOUT THE WRITTEN PERMISSION OF SEE SECURITY PTY LTD IS PROHIBITED.	DEBUR AND BREAK SHARP EDGES	DO NOT SCALE DRAWING	REVISION
FINISH:				
NAME	SIGNATURE	DATE		
DRAWN	ADC	14/10/2016	DWG NO.	A3
MATERIAL:	Weight		SB00248A03	
Steel galvanised	7.5 kg		SCALE:1:5	SHEET 50 OF 84

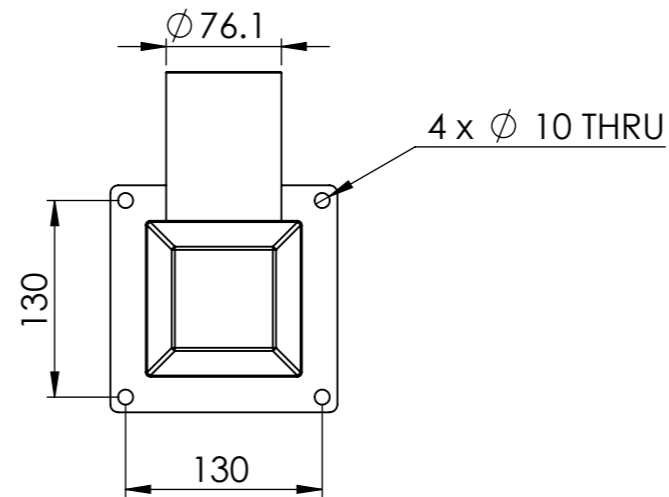
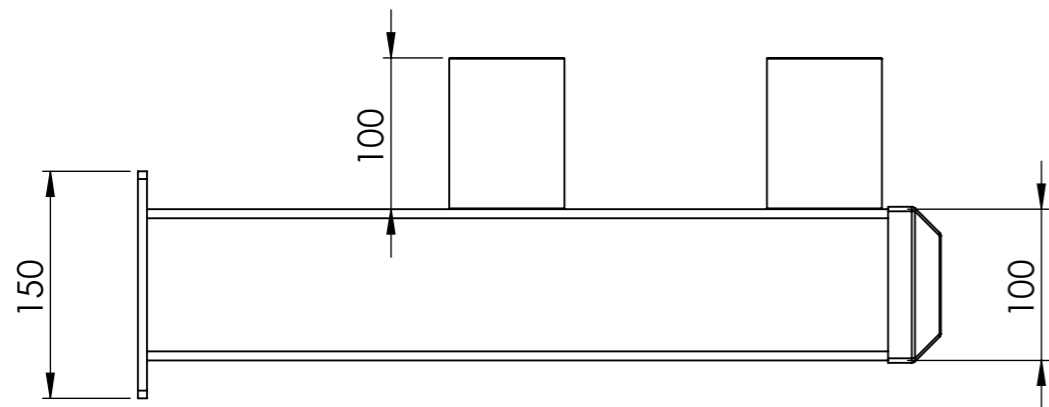
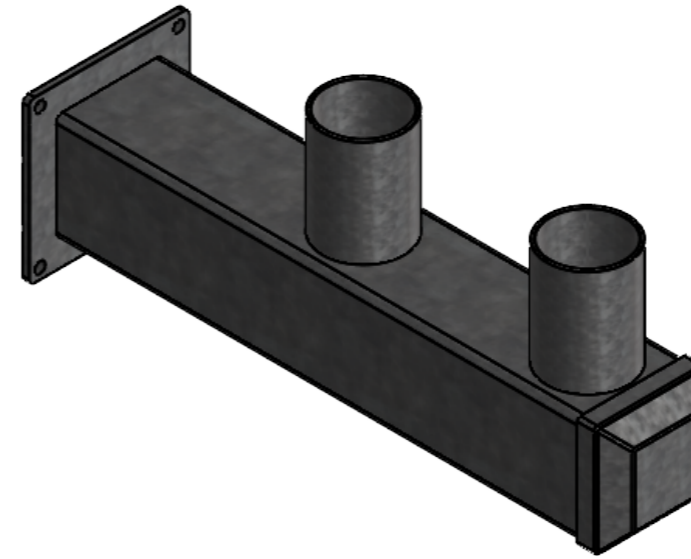
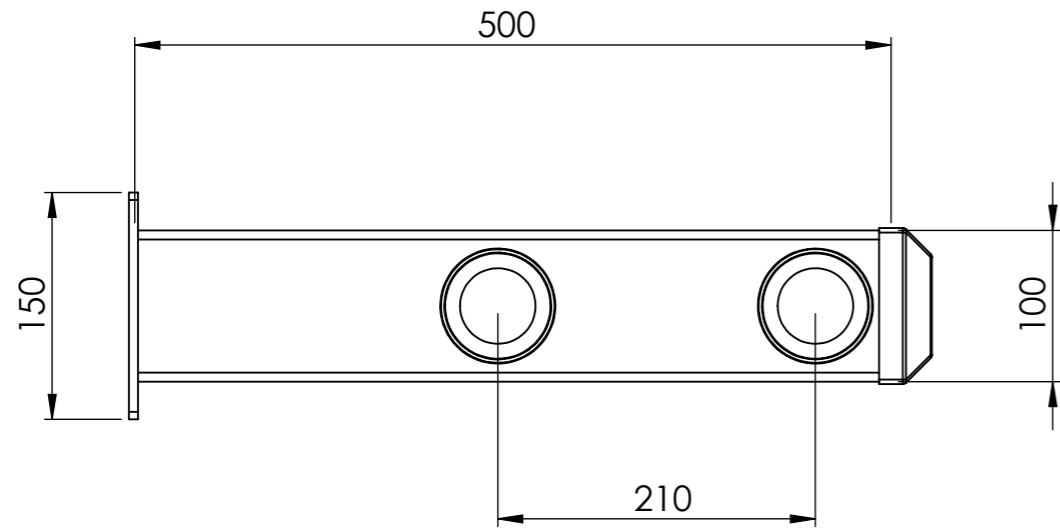

UNLESS OTHERWISE SPECIFIED: DIMENSIONS ARE IN MILLIMETERS	PROPRIETARY AND CONFIDENTIAL THE INFORMATION CONTAINED IN THIS DRAWING IS THE SOLE PROPERTY OF SEE SECURITY PTY LTD. ANY REPRODUCTION IN PART OR AS A WHOLE WITHOUT THE WRITTEN PERMISSION OF SEE SECURITY PTY LTD IS PROHIBITED.	DEBUR AND BREAK SHARP EDGES	DO NOT SCALE DRAWING	REVISION
FINISH:			 SEE SECURITY SECURITY & EQUIPMENT END. OFFERS	
NAME	SIGNATURE	DATE		
DRAWN	ADC	14/10/2016	DWG NO.	A3
MATERIAL:	Weight		SB00250A02	
Steel galvanised	6.4kg		SCALE:1:5	SHEET 51 OF 84

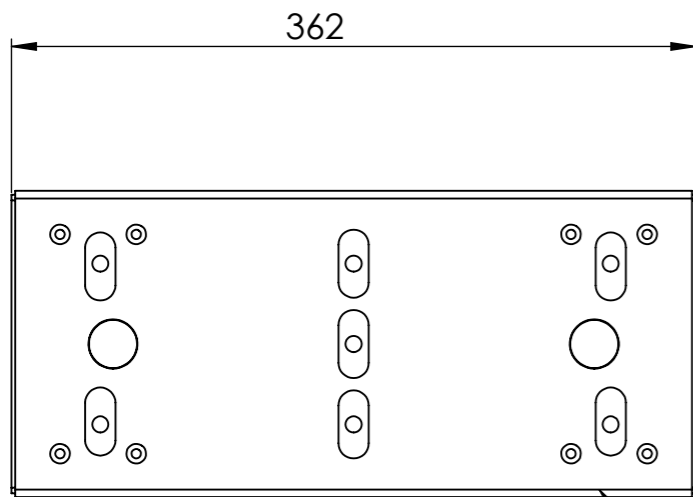

To suit SMW5 wedge housing

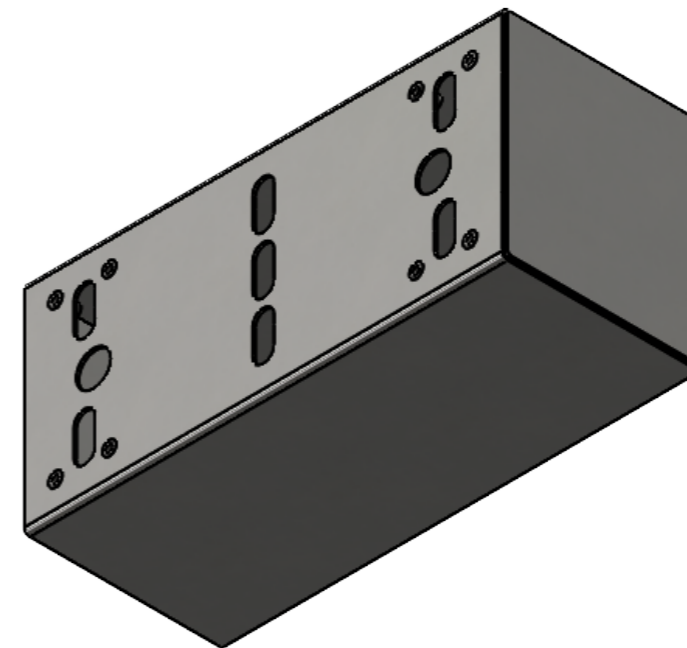
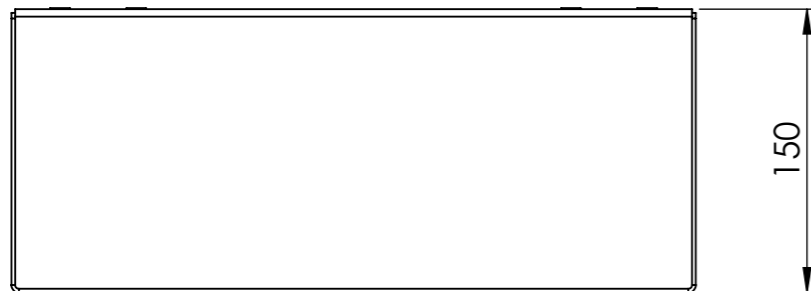

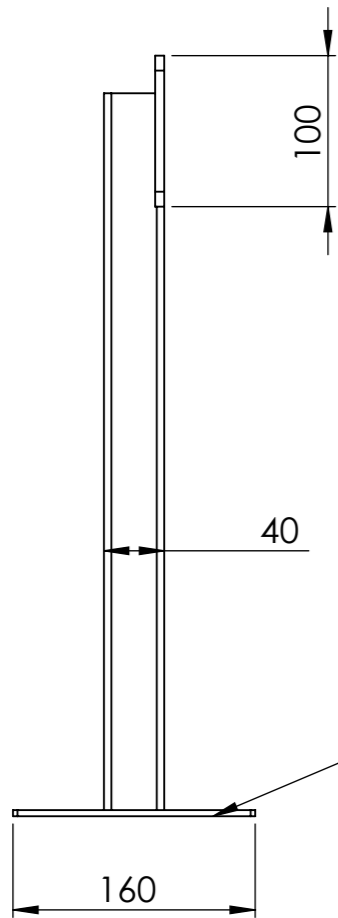
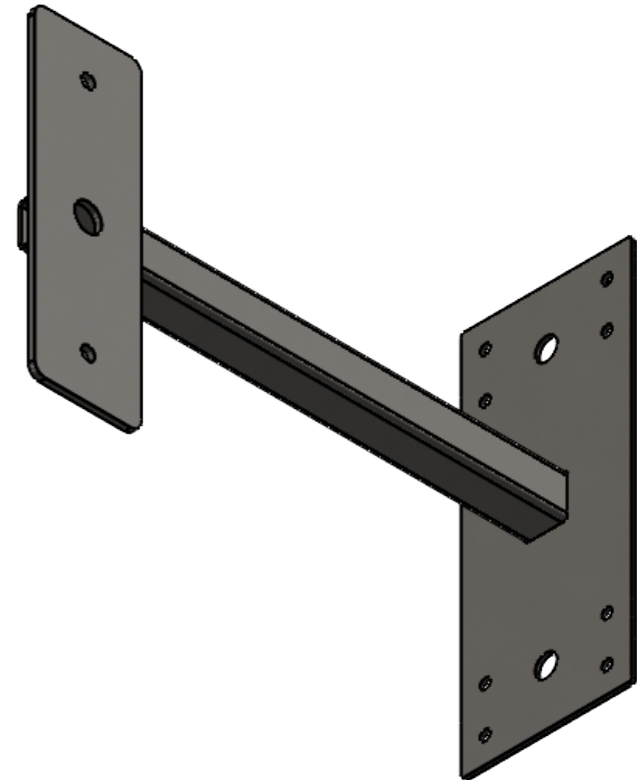
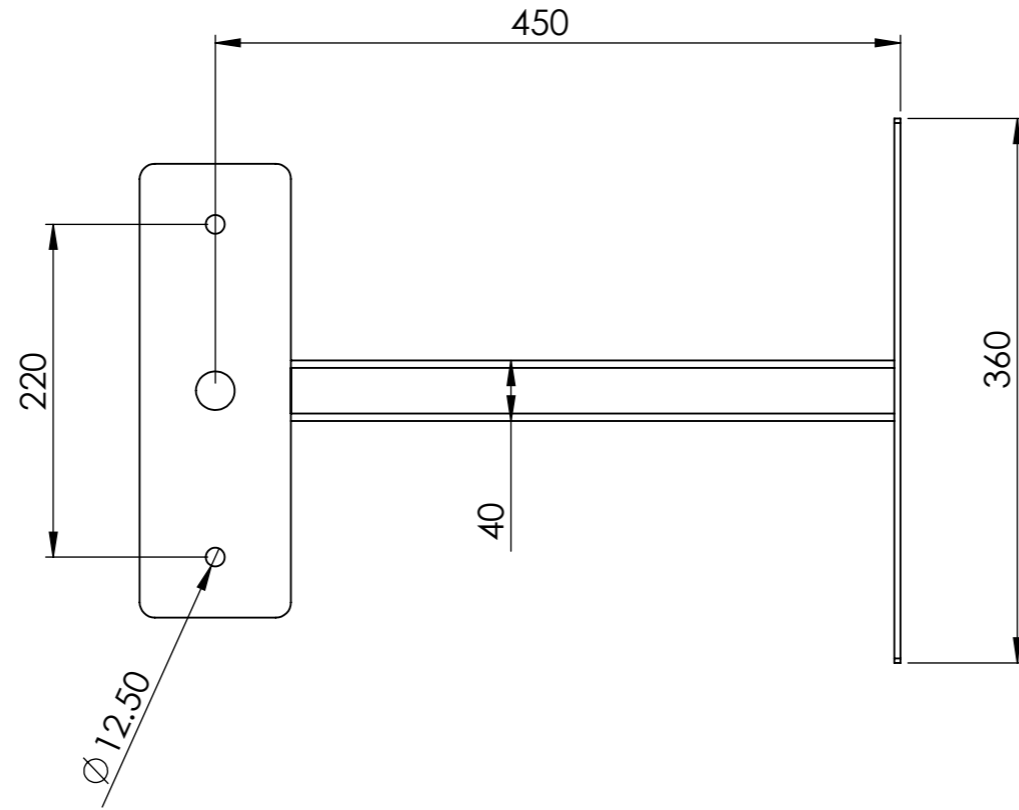
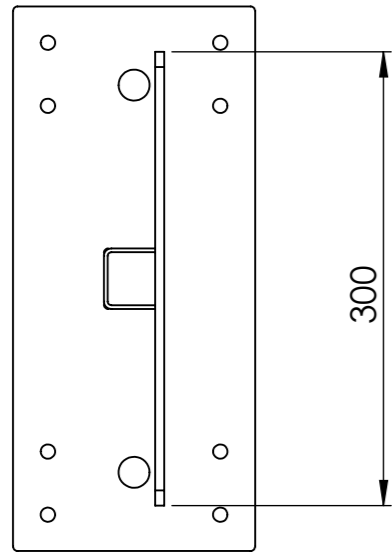

UNLESS OTHERWISE SPECIFIED: DIMENSIONS ARE IN MILLIMETERS	PROPRIETARY AND CONFIDENTIAL THE INFORMATION CONTAINED IN THIS DRAWING IS THE SOLE PROPERTY OF SEE SECURITY PTY LTD. ANY REPRODUCTION IN PART OR AS A WHOLE WITHOUT THE WRITTEN PERMISSION OF SEE SECURITY PTY LTD IS PROHIBITED.	DEBUR AND BREAK SHARP EDGES	DO NOT SCALE DRAWING	REVISION
FINISH:				
NAME	SIGNATURE	DATE		
DRAWN	ADC	14/10/2016		
MATERIAL:	Weight		DWG NO.	A3
Steel powder coated	4kg		SB00250A03	
			SCALE:1:5	SHEET 52 OF 84

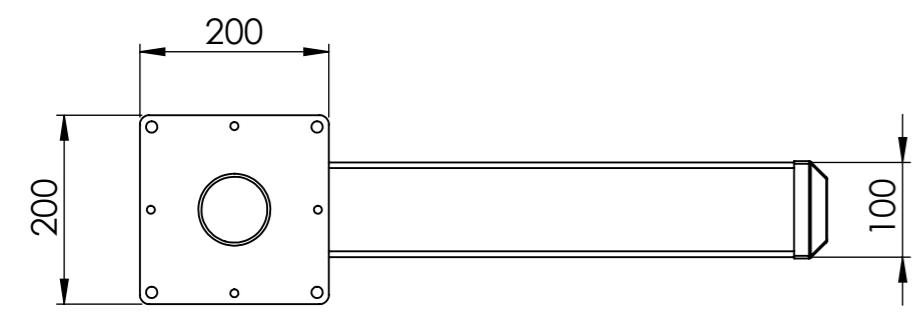
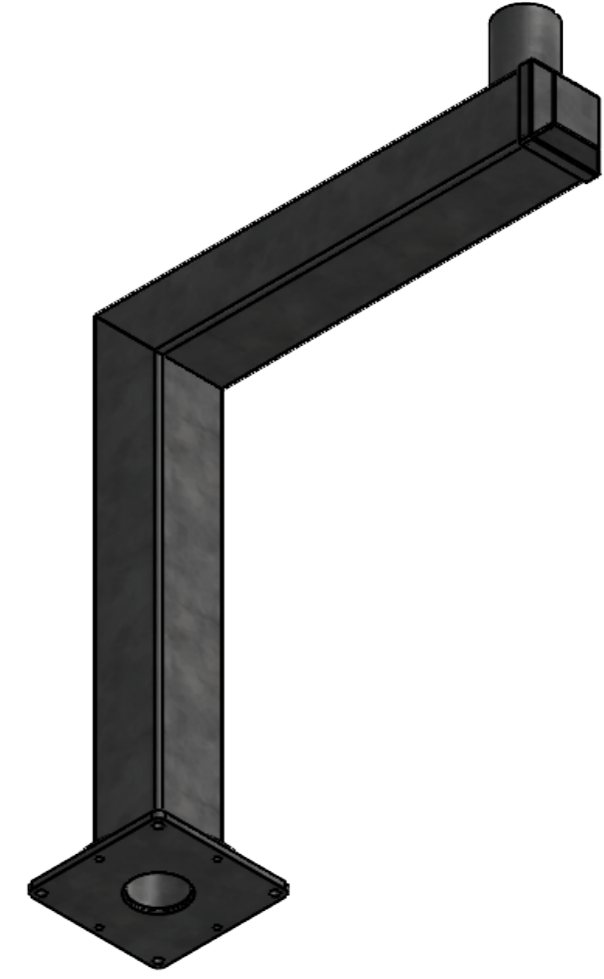
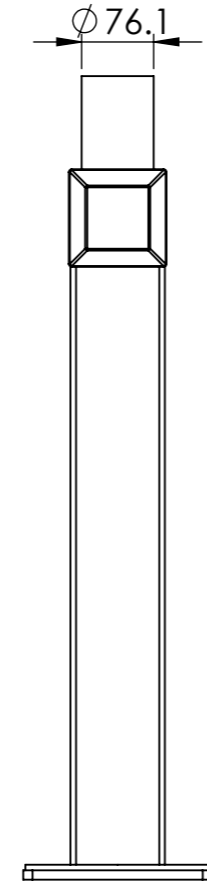
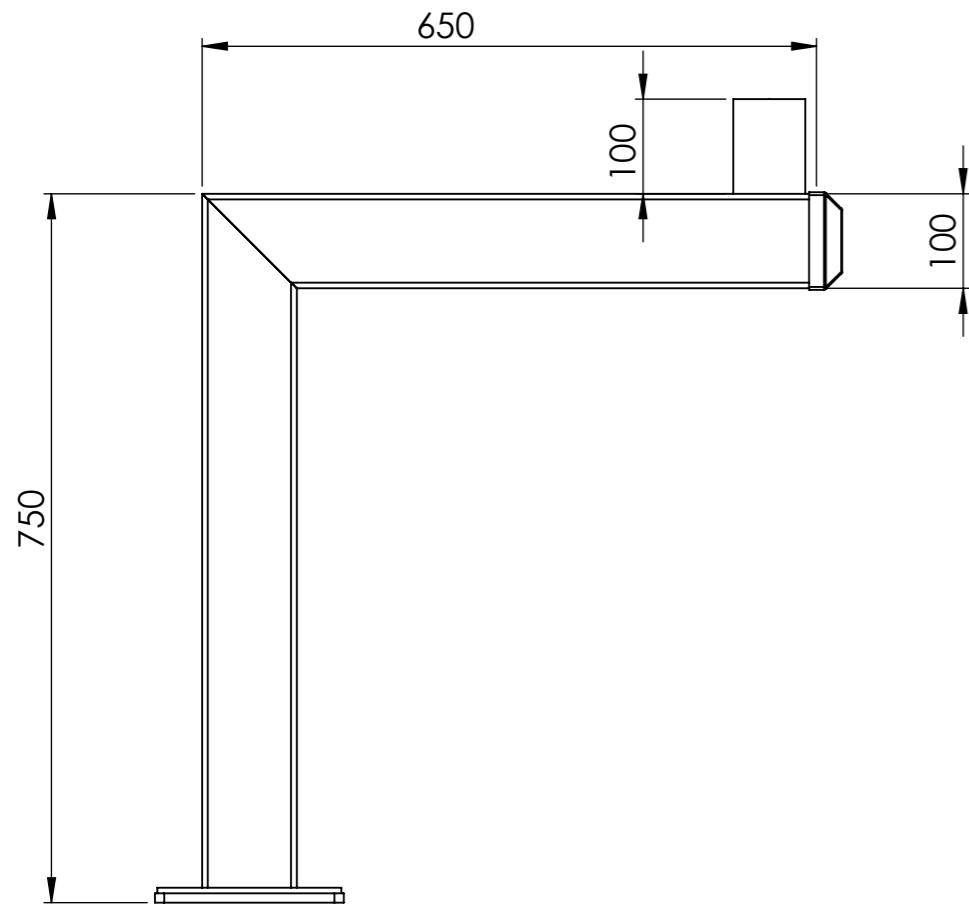

To suit SMW5 wedge housing

UNLESS OTHERWISE SPECIFIED: DIMENSIONS ARE IN MILLIMETERS	PROPRIETARY AND CONFIDENTIAL THE INFORMATION CONTAINED IN THIS DRAWING IS THE SOLE PROPERTY OF SEE SECURITY PTY LTD. ANY REPRODUCTION IN PART OR AS A WHOLE WITHOUT THE WRITTEN PERMISSION OF SEE SECURITY PTY LTD IS PROHIBITED.	DEBUR AND BREAK SHARP EDGES	DO NOT SCALE DRAWING	REVISION
FINISH:				
NAME	SIGNATURE	DATE		
DRAWN	ADC	14/10/2016		
MATERIAL:	Weight		DWG NO.	A3
Steel galvanised	4,4kg		SB00255A01	
			SCALE:1:5	SHEET 53 OF 84



UNLESS OTHERWISE SPECIFIED: DIMENSIONS ARE IN MILLIMETERS	PROPRIETARY AND CONFIDENTIAL THE INFORMATION CONTAINED IN THIS DRAWING IS THE SOLE PROPERTY OF SEE SECURITY PTY LTD. ANY REPRODUCTION IN PART OR AS A WHOLE WITHOUT THE WRITTEN PERMISSION OF SEE SECURITY PTY LTD IS PROHIBITED.	DEBUR AND BREAK SHARP EDGES	DO NOT SCALE DRAWING	REVISION
FINISH:				
NAME	SIGNATURE	DATE		
DRAWN	ADC	14/10/2016	DWG NO.	A3
MATERIAL:	Weight			
Steel galvanised	18kg		SB00268A01	
			SCALE:1:5	SHEET 54 OF 84

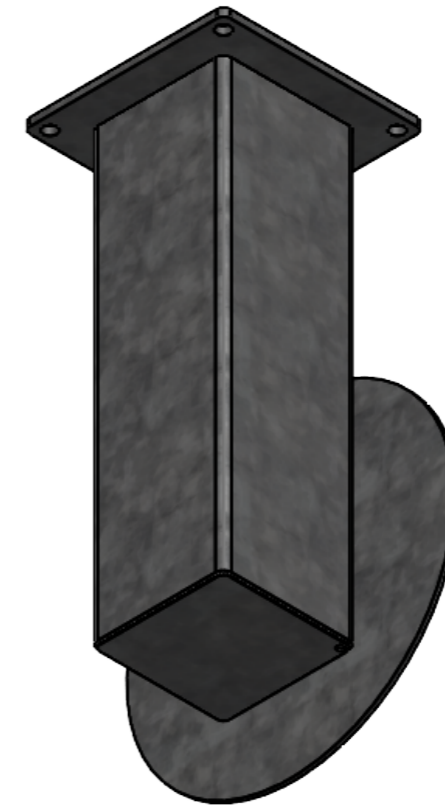
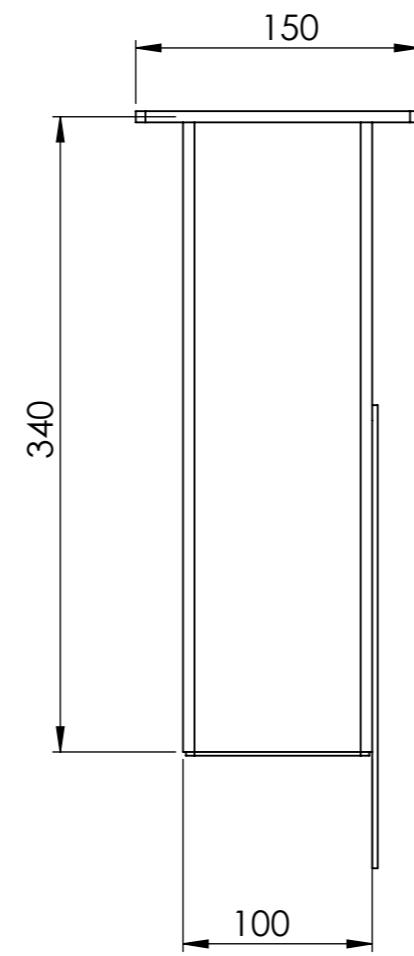
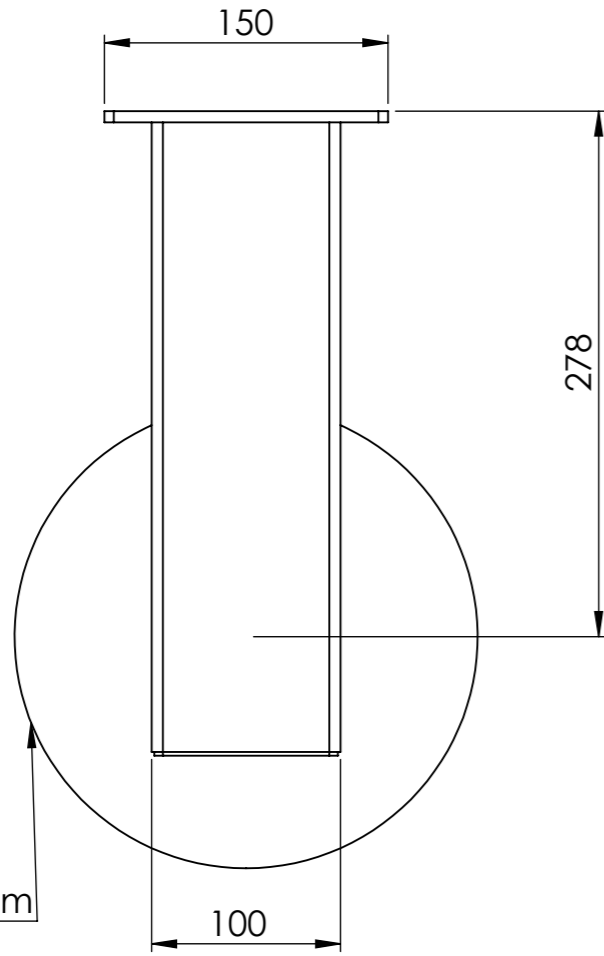

To suit quad cam

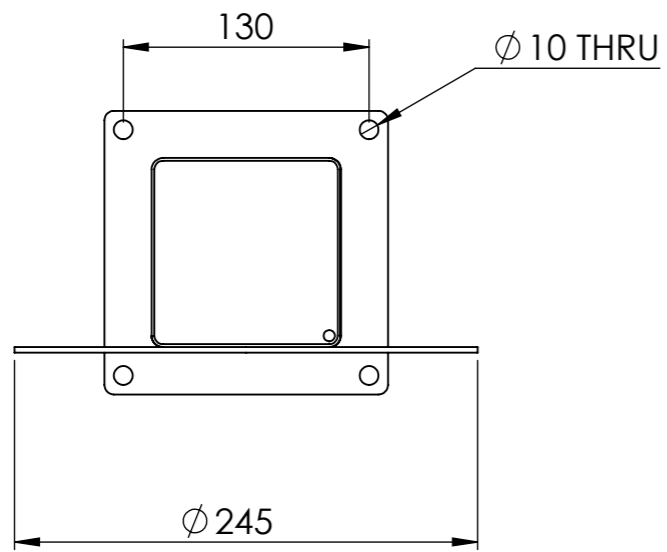

UNLESS OTHERWISE SPECIFIED: DIMENSIONS ARE IN MILLIMETERS	PROPRIETARY AND CONFIDENTIAL THE INFORMATION CONTAINED IN THIS DRAWING IS THE SOLE PROPERTY OF SEE SECURITY PTY LTD. ANY REPRODUCTION IN PART OR AS A WHOLE WITHOUT THE WRITTEN PERMISSION OF SEE SECURITY PTY LTD IS PROHIBITED.	DEBUR AND BREAK SHARP EDGES	DO NOT SCALE DRAWING	REVISION
FINISH:				
NAME	SIGNATURE	DATE		
DRAWN	ADC	14/10/2016	DWG NO.	A3
MATERIAL:	Weight			
Steel galvanised	4.7kg		SB00536A02	
			SCALE:1:5	SHEET 55 OF 84

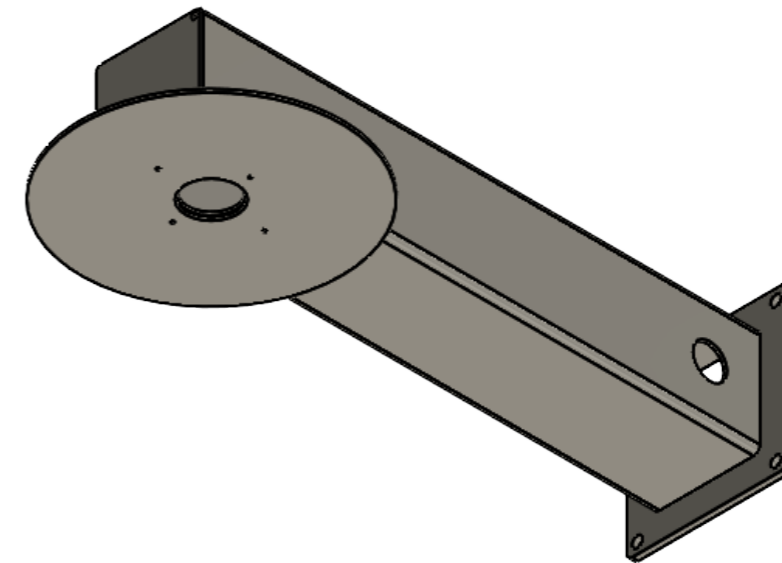
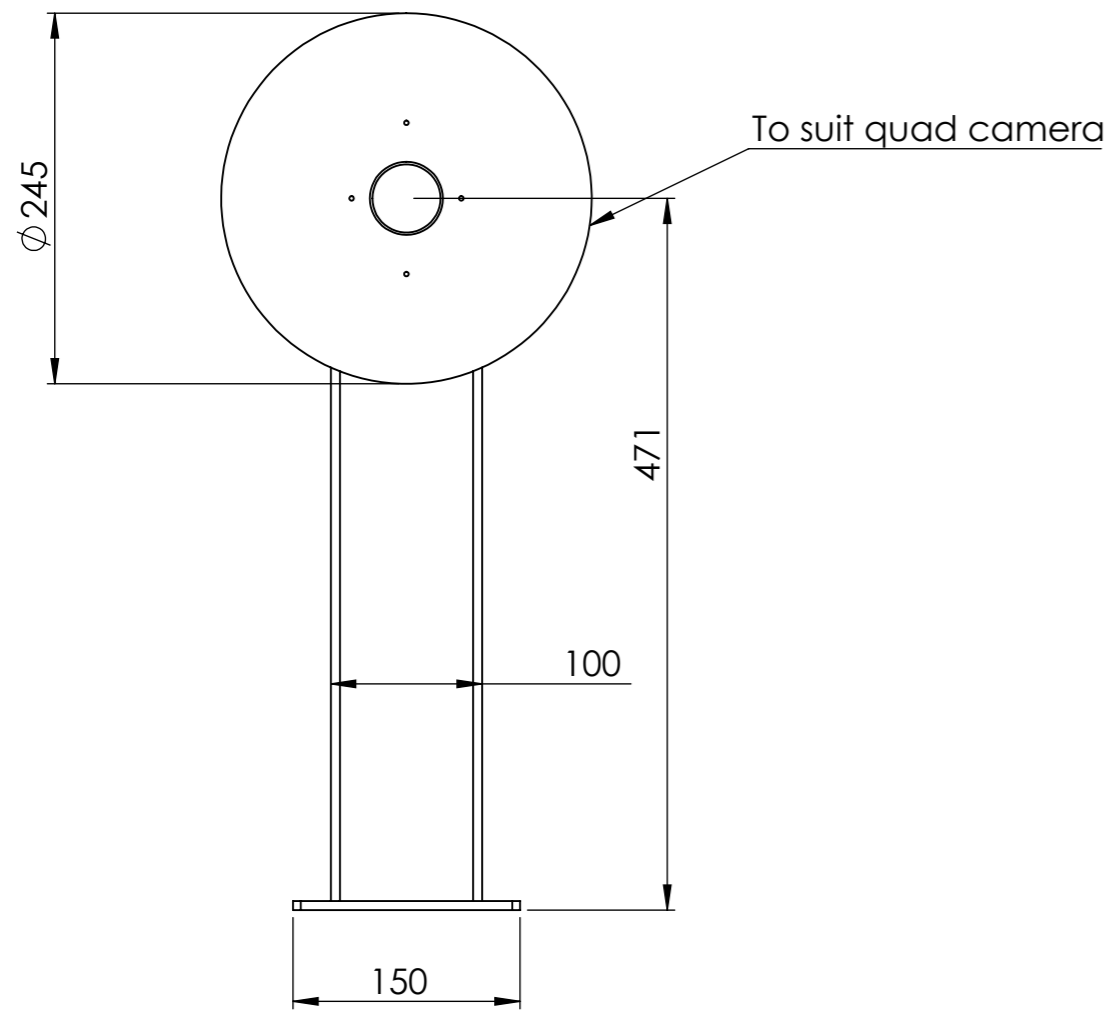
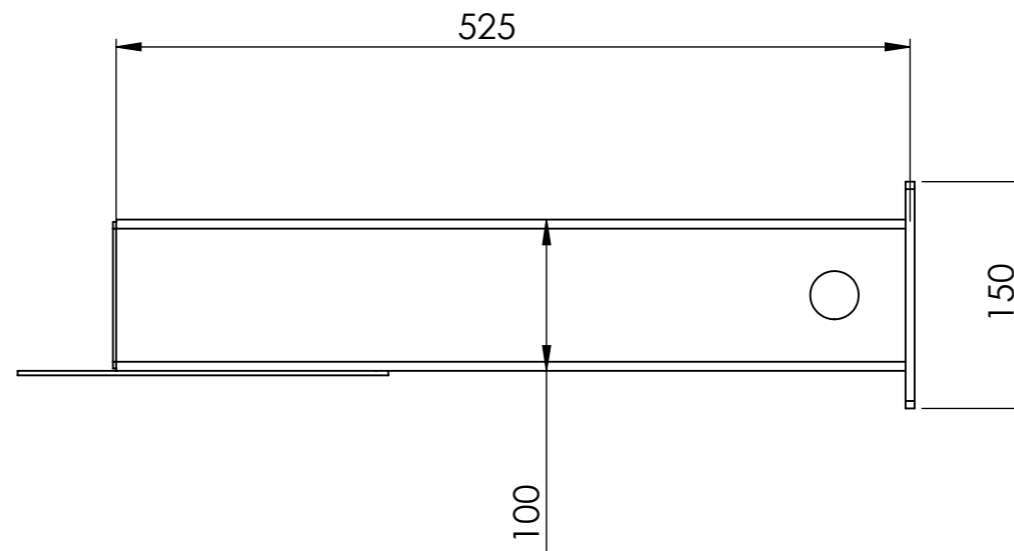
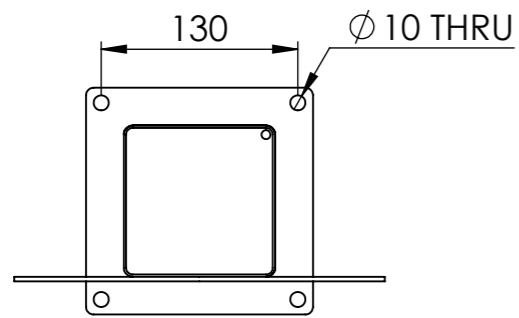

UNLESS OTHERWISE SPECIFIED: DIMENSIONS ARE IN MILLIMETERS	PROPRIETARY AND CONFIDENTIAL THE INFORMATION CONTAINED IN THIS DRAWING IS THE SOLE PROPERTY OF SEE SECURITY PTY LTD. ANY REPRODUCTION IN PART OR AS A WHOLE WITHOUT THE WRITTEN PERMISSION OF SEE SECURITY PTY LTD IS PROHIBITED.	DEBUR AND BREAK SHARP EDGES	DO NOT SCALE DRAWING	REVISION
FINISH:				
NAME	SIGNATURE	DATE		
DRAWN	ADC	14/10/2016		
MATERIAL:	Weight	DWG NO.		A3
Steel galvanised	6.4kg	SB00536A04		
		SCALE:1:5	SHEET 56 OF 84	

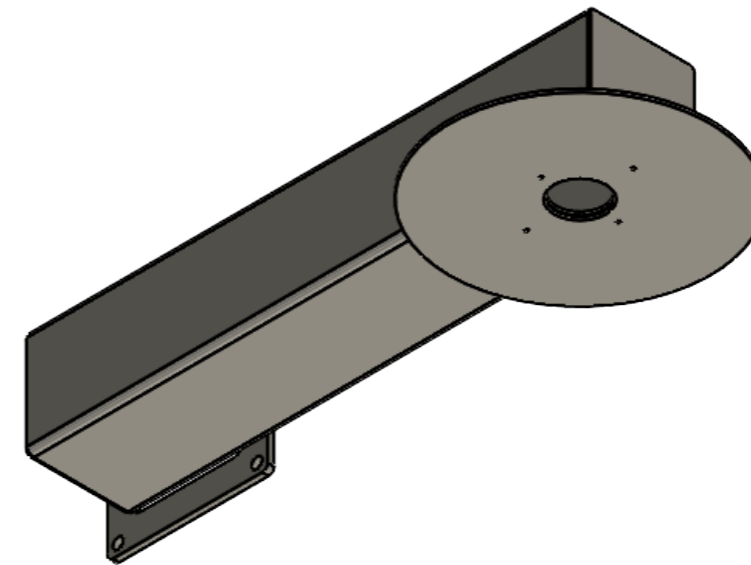
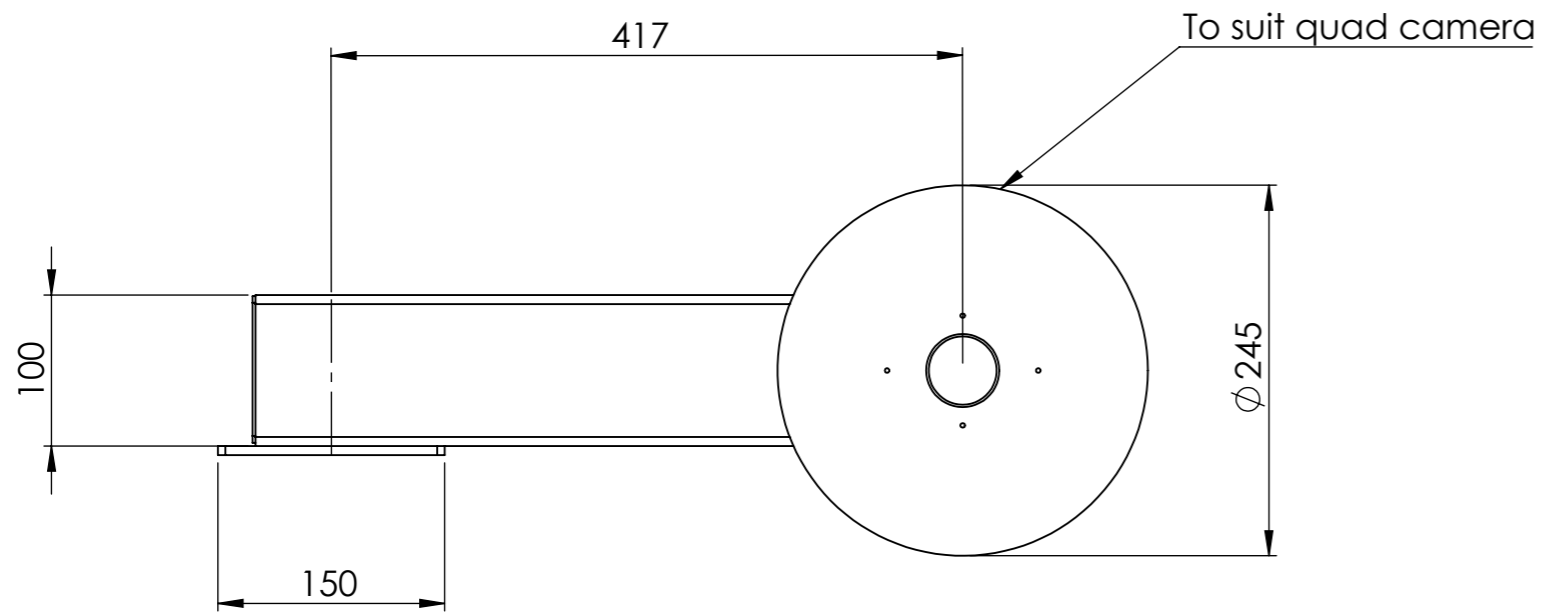
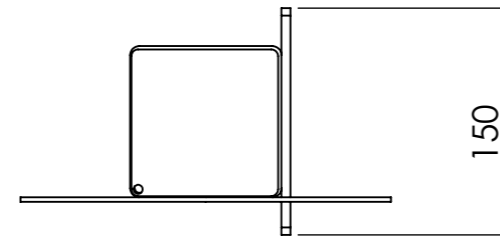
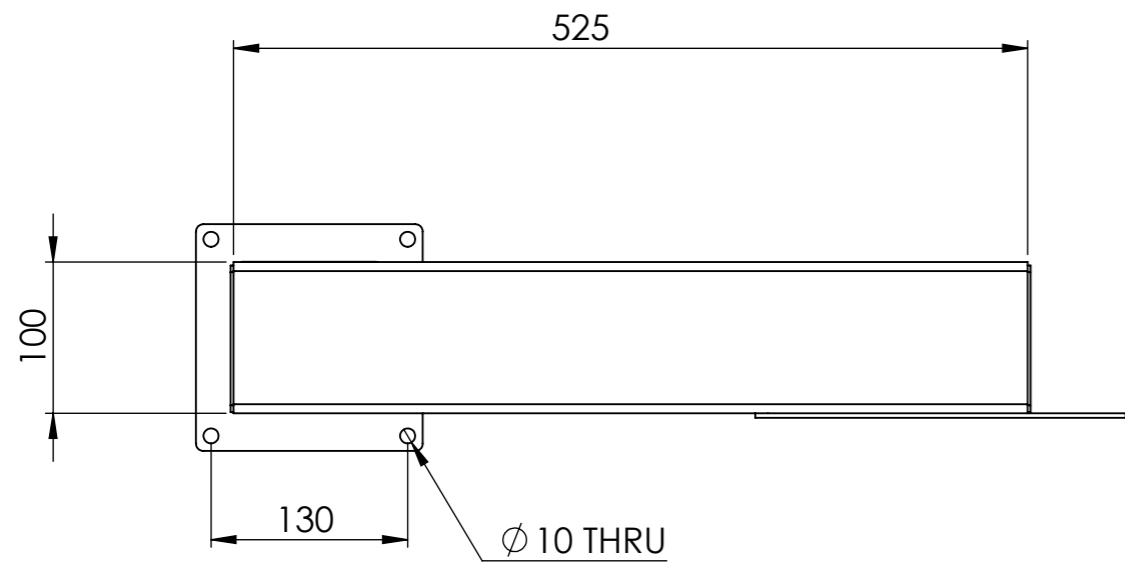

UNLESS OTHERWISE SPECIFIED: DIMENSIONS ARE IN MILLIMETERS	PROPRIETARY AND CONFIDENTIAL THE INFORMATION CONTAINED IN THIS DRAWING IS THE SOLE PROPERTY OF SEE SECURITY PTY LTD. ANY REPRODUCTION IN PART OR AS A WHOLE WITHOUT THE WRITTEN PERMISSION OF SEE SECURITY PTY LTD IS PROHIBITED.	DEBUR AND BREAK SHARP EDGES	DO NOT SCALE DRAWING	REVISION
FINISH:				
NAME	SIGNATURE	DATE		
DRAWN	ADC	14/10/2016		
MATERIAL:	Weight	DWG NO.		A3
Steel galvanised	6.5kg	SB00536A06		
		SCALE:1:5	SHEET 57 OF 84	

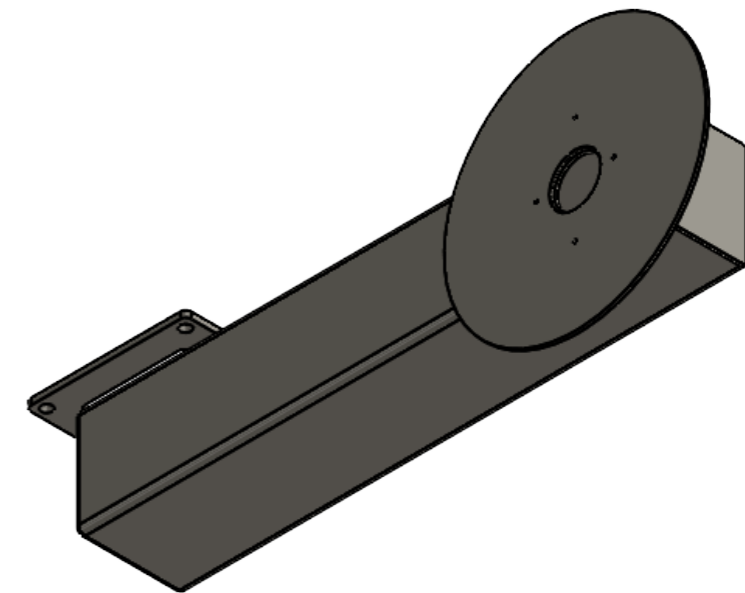
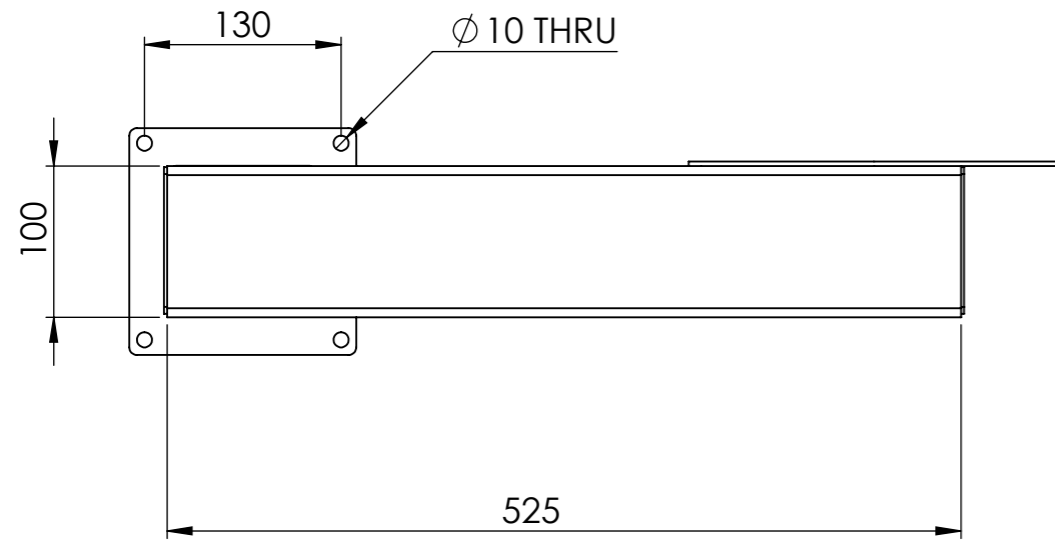
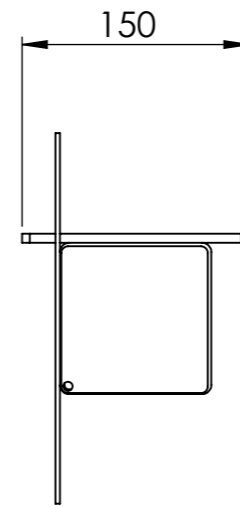
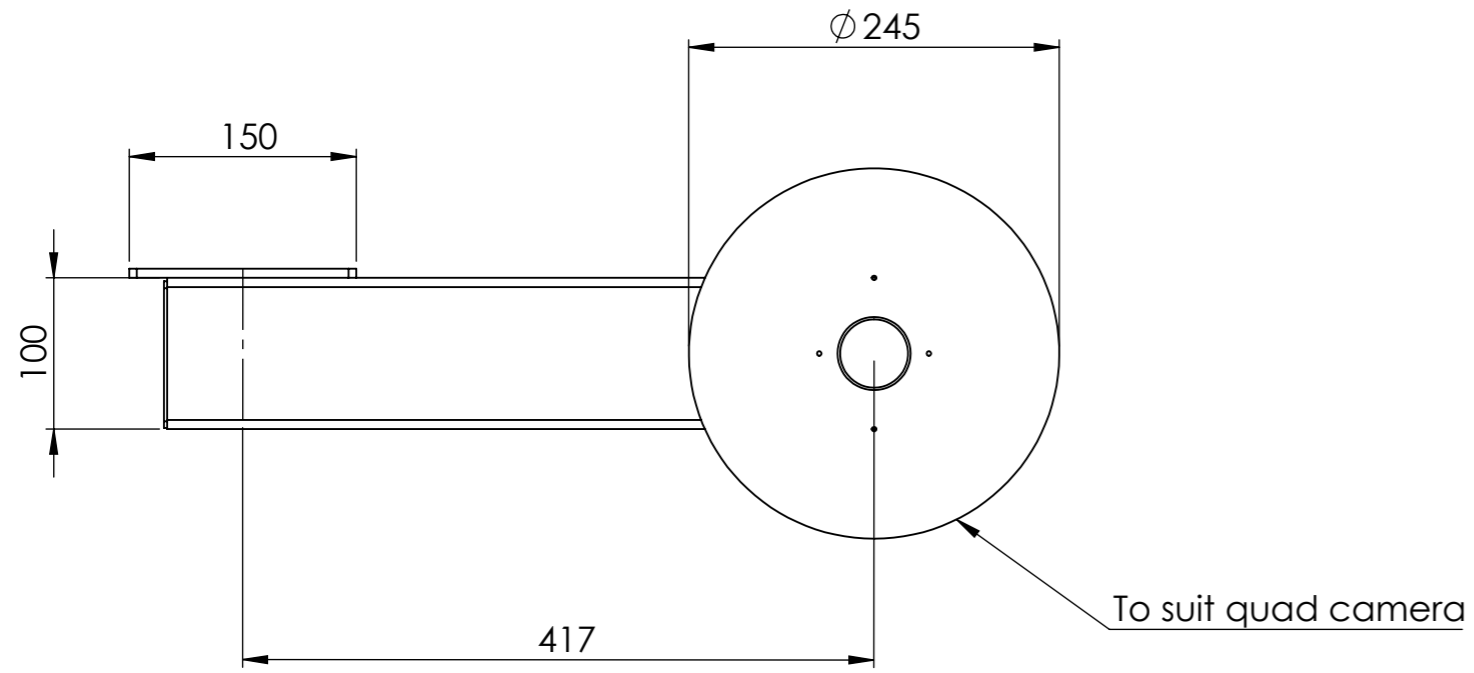

UNLESS OTHERWISE SPECIFIED: DIMENSIONS ARE IN MILLIMETERS	PROPRIETARY AND CONFIDENTIAL THE INFORMATION CONTAINED IN THIS DRAWING IS THE SOLE PROPERTY OF SEE SECURITY PTY LTD. ANY REPRODUCTION IN PART OR AS A WHOLE WITHOUT THE WRITTEN PERMISSION OF SEE SECURITY PTY LTD IS PROHIBITED.	DEBUR AND BREAK SHARP EDGES	DO NOT SCALE DRAWING	REVISION
FINISH:			 SEE SECURITY SECURITY & EQUIPMENT END. OFFERS	
NAME	SIGNATURE	DATE		
DRAWN	ADC	14/10/2016	DWG NO.	A3
MATERIAL:	Weight		SB00536A08	
Steel galvanised	6.5kg		SCALE:1:5	SHEET 58 OF 84

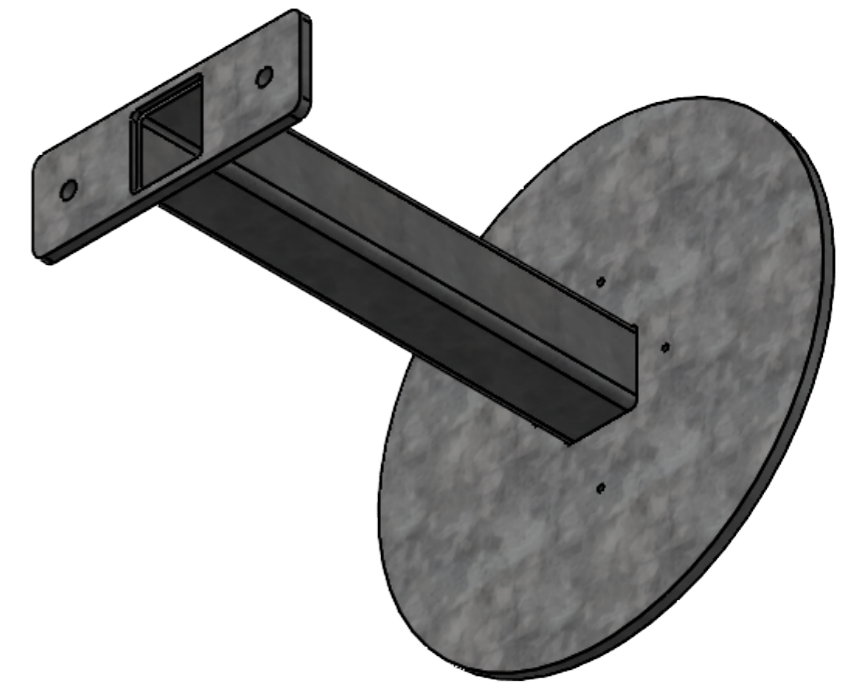
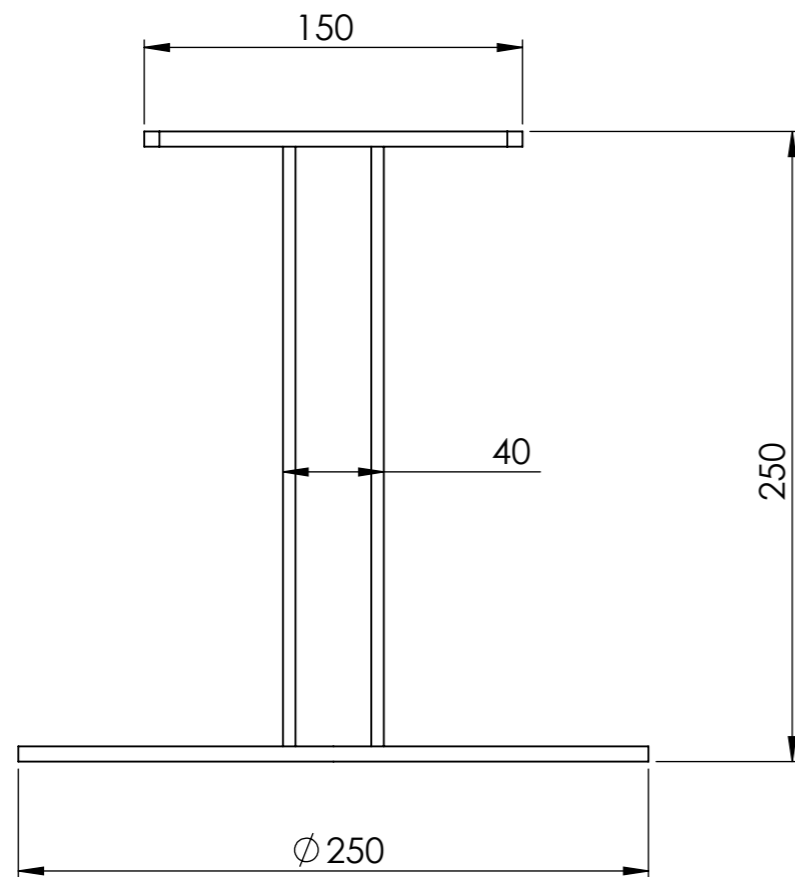
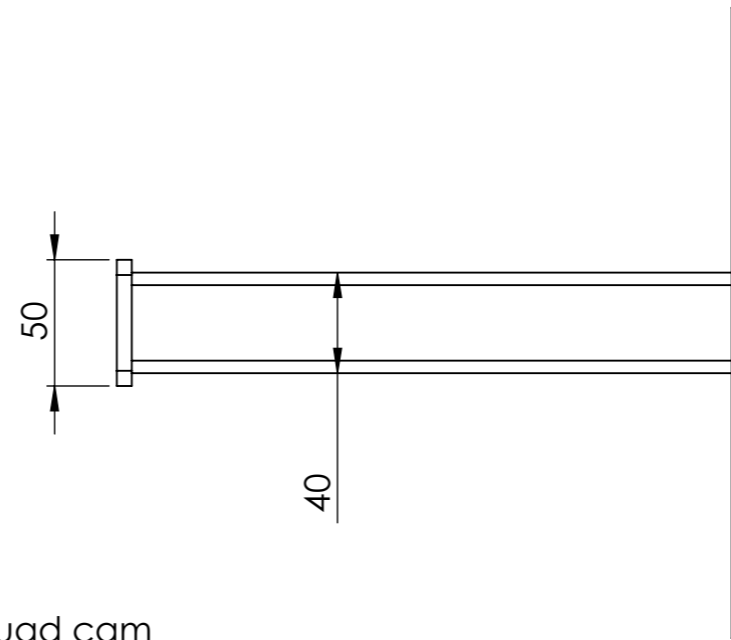
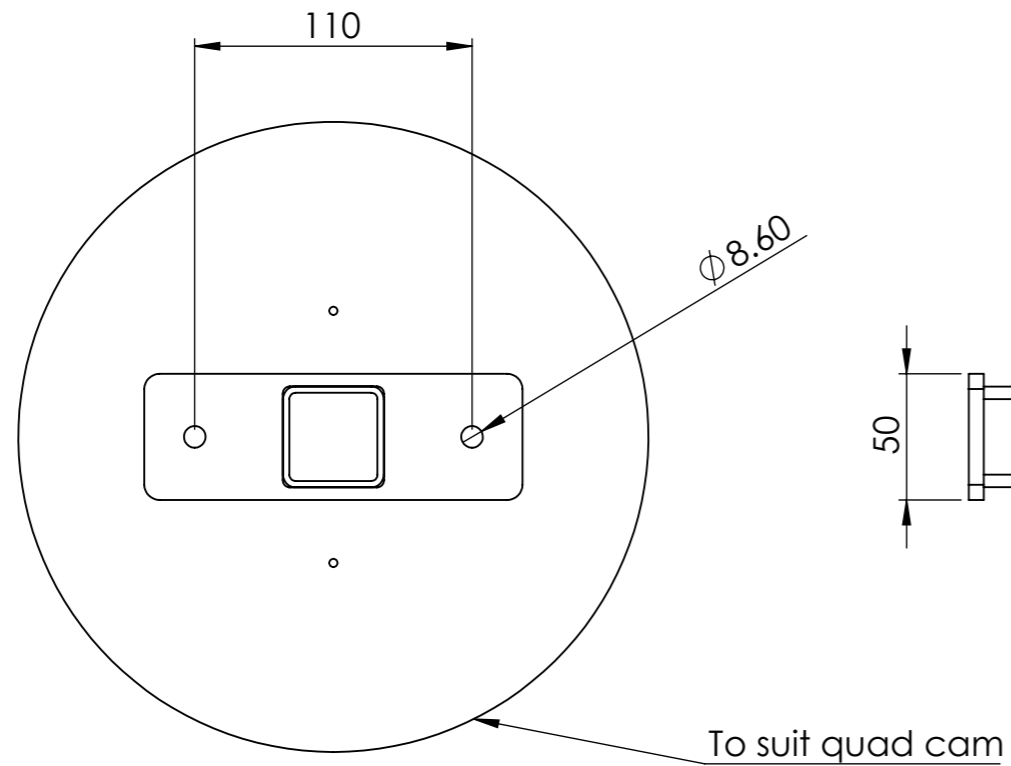

UNLESS OTHERWISE SPECIFIED: DIMENSIONS ARE IN MILLIMETERS	PROPRIETARY AND CONFIDENTIAL THE INFORMATION CONTAINED IN THIS DRAWING IS THE SOLE PROPERTY OF SEE SECURITY PTY LTD. ANY REPRODUCTION IN PART OR AS A WHOLE WITHOUT THE WRITTEN PERMISSION OF SEE SECURITY PTY LTD IS PROHIBITED.	DEBUR AND BREAK SHARP EDGES	DO NOT SCALE DRAWING	REVISION
FINISH:				
NAME	SIGNATURE	DATE		
DRAWN	ADC	14/10/2016		
MATERIAL: Steel galvanised	Weight 3.2kg	DWG NO. SB00662A01	A3	
		SCALE:1:5	SHEET 59 OF 84	

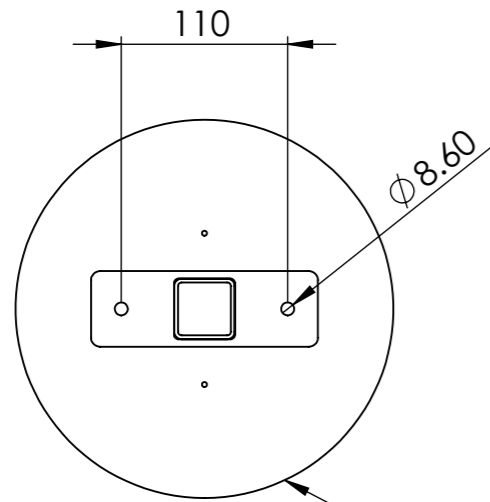

To suit quad cam

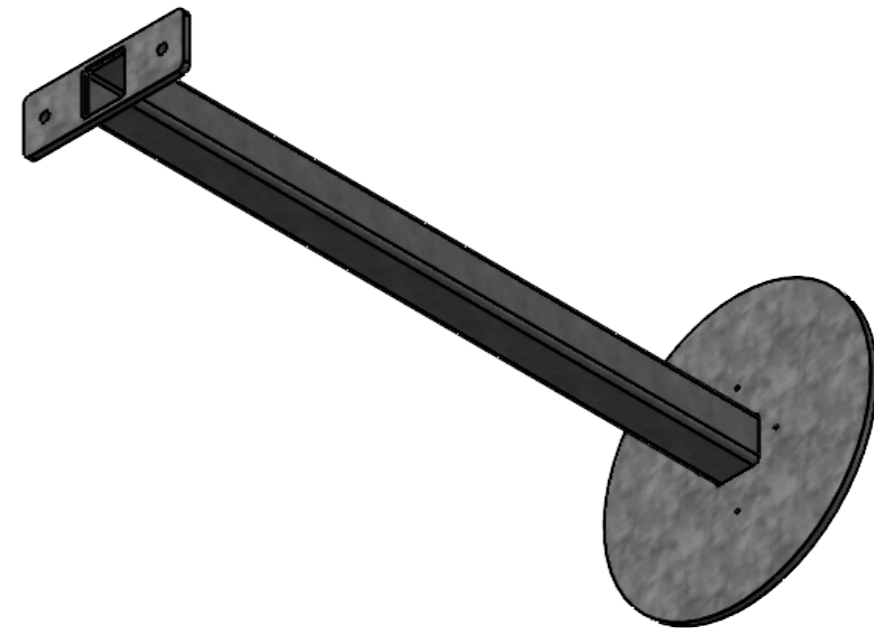
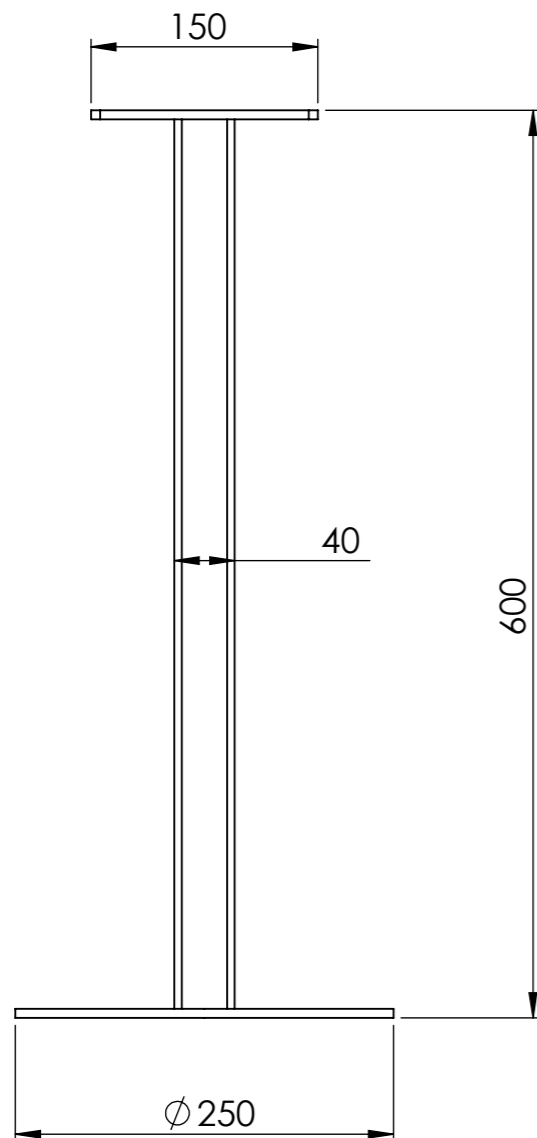
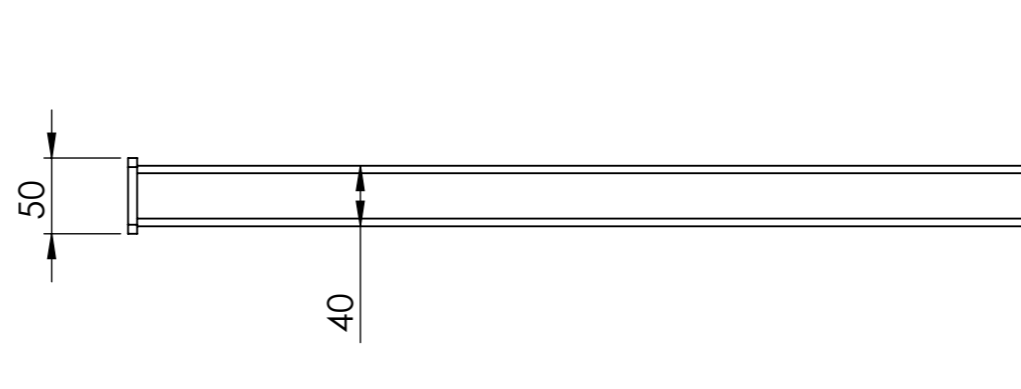

UNLESS OTHERWISE SPECIFIED: DIMENSIONS ARE IN MILLIMETERS	PROPRIETARY AND CONFIDENTIAL THE INFORMATION CONTAINED IN THIS DRAWING IS THE SOLE PROPERTY OF SEE SECURITY PTY LTD. ANY REPRODUCTION IN PART OR AS A WHOLE WITHOUT THE WRITTEN PERMISSION OF SEE SECURITY PTY LTD IS PROHIBITED.	DEBUR AND BREAK SHARP EDGES	DO NOT SCALE DRAWING	REVISION
FINISH:				
NAME	SIGNATURE	DATE		
DRAWN	ADC	14/10/2016		
MATERIAL:	Weight		DWG NO.	A3
Steel galvanised	4.2kg		SB00662A02	
			SCALE:1:5	SHEET 60 OF 84

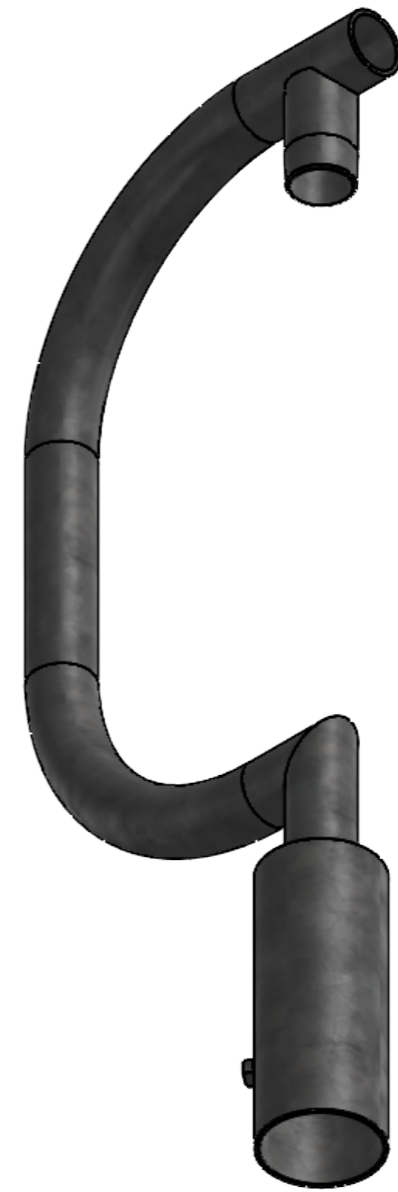
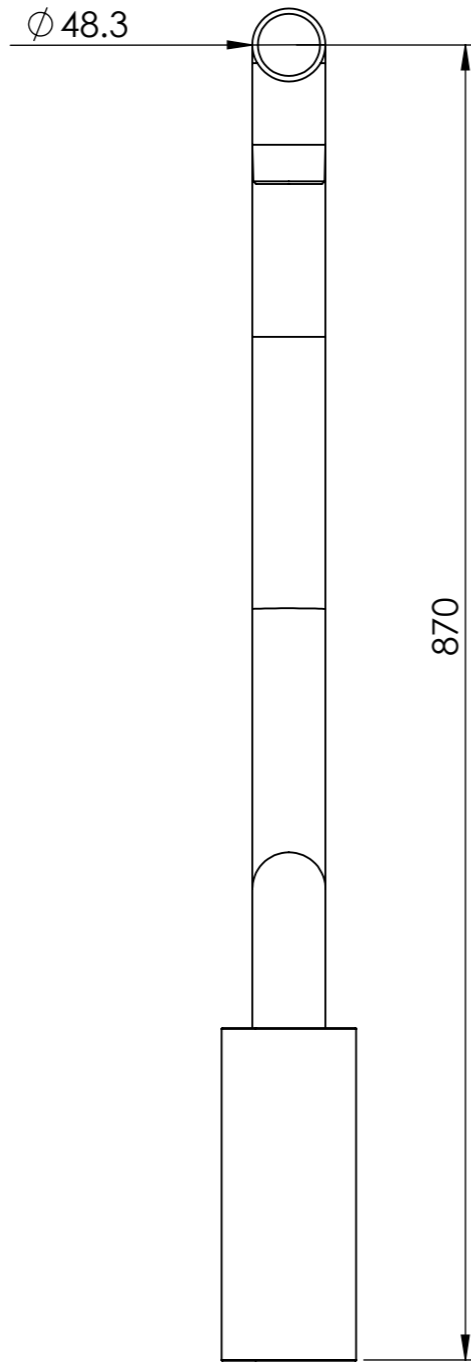
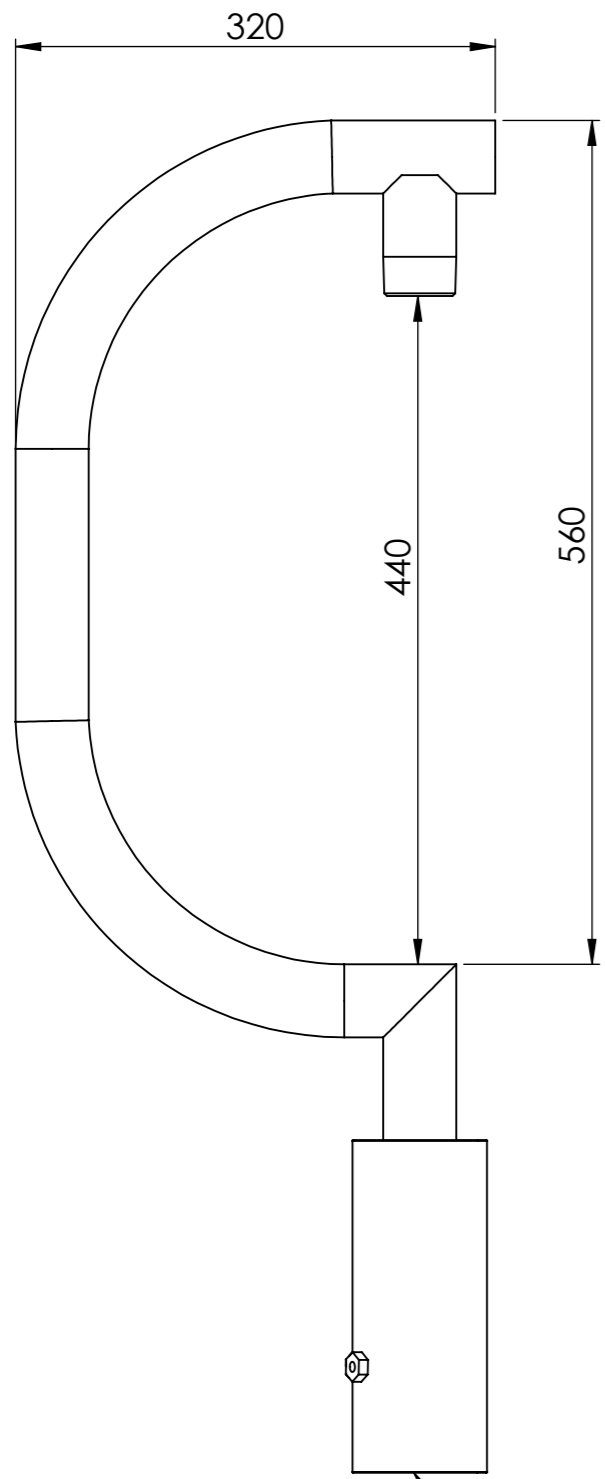

To suit 76.1 spigot

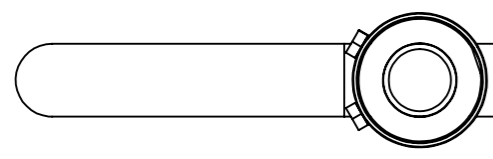

UNLESS OTHERWISE SPECIFIED: DIMENSIONS ARE IN MILLIMETERS	PROPRIETARY AND CONFIDENTIAL THE INFORMATION CONTAINED IN THIS DRAWING IS THE SOLE PROPERTY OF SEE SECURITY PTY LTD. ANY REPRODUCTION IN PART OR AS A WHOLE WITHOUT THE WRITTEN PERMISSION OF SEE SECURITY PTY LTD IS PROHIBITED.	DEBUR AND BREAK SHARP EDGES	DO NOT SCALE DRAWING	REVISION
FINISH:				
NAME	SIGNATURE	DATE		
DRAWN	ADC	14/10/2016	DWG NO.	A3
MATERIAL:	Weight		SB00738A10	
Steel galvanised	6.2kg		SCALE:1:5	SHEET 61 OF 84

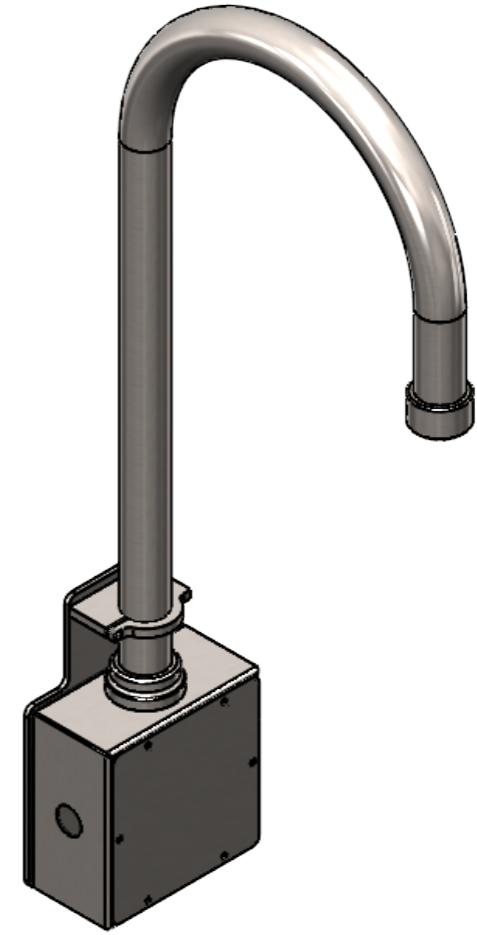
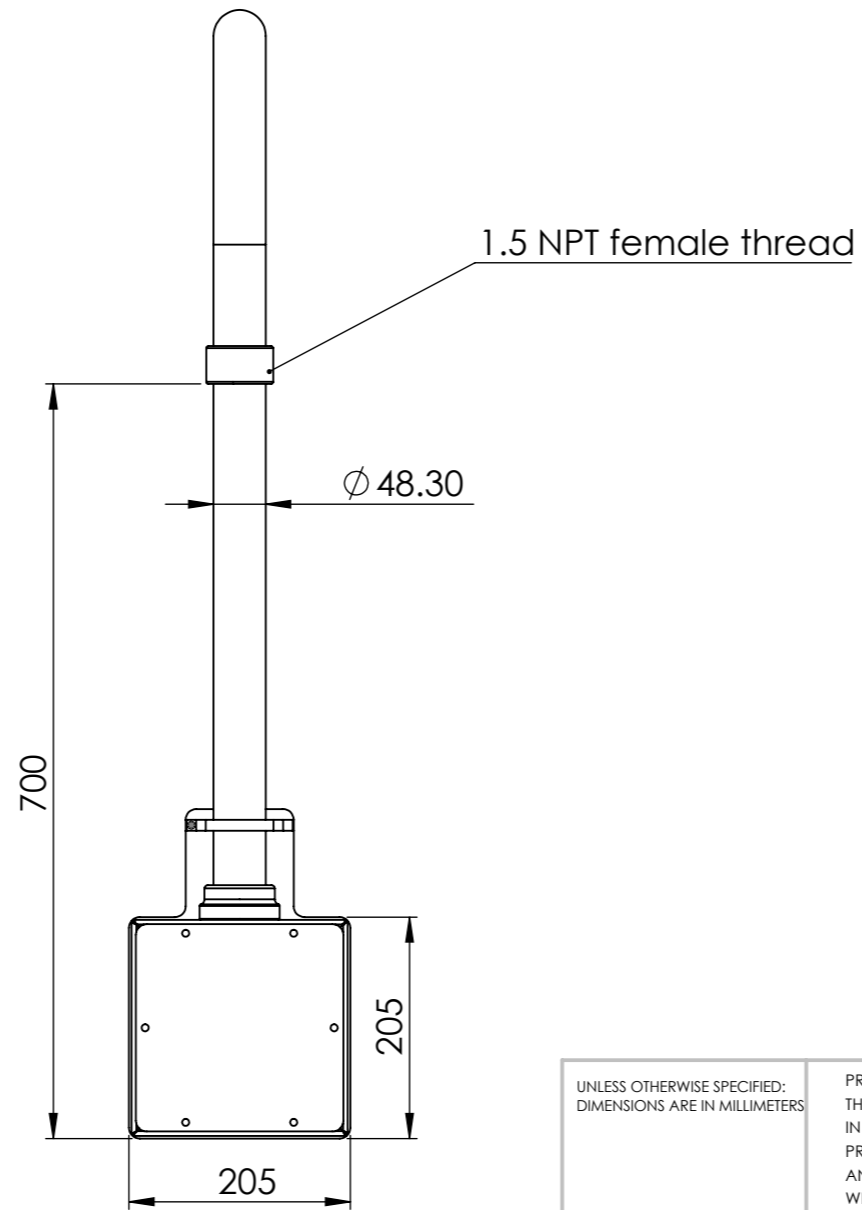
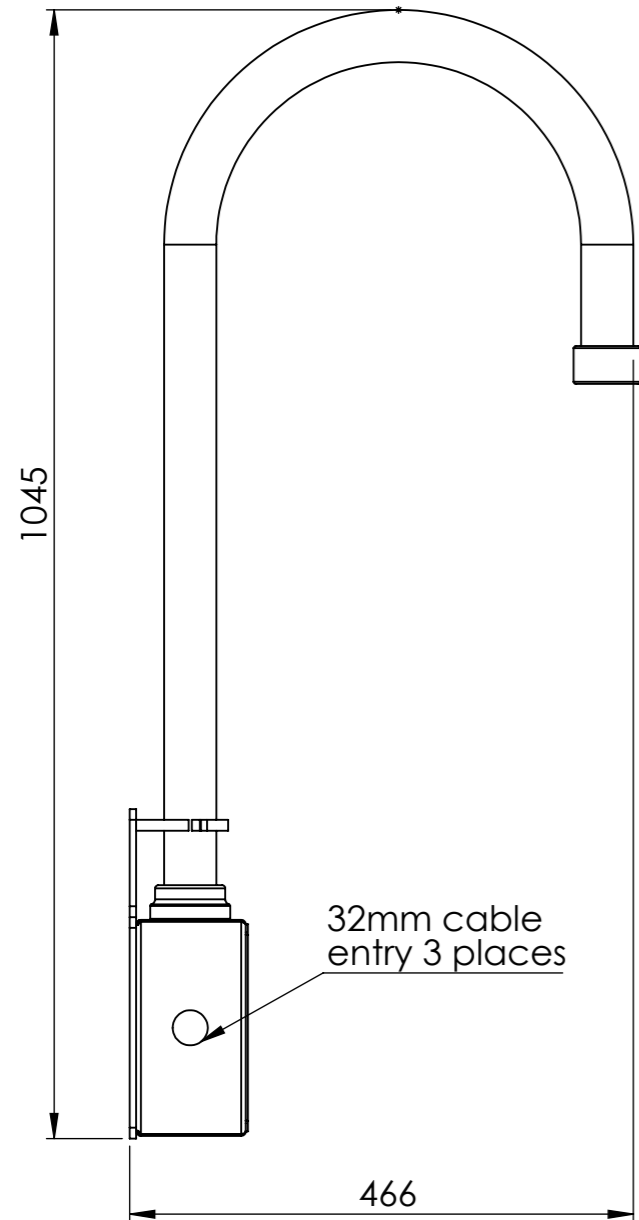
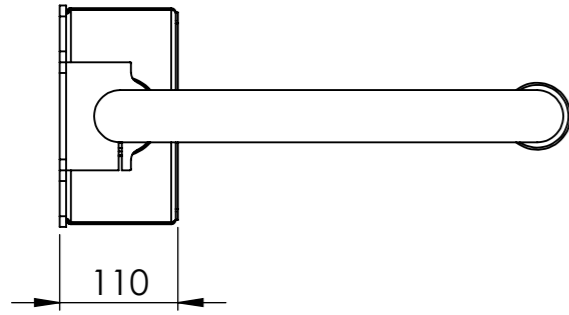

UNLESS OTHERWISE SPECIFIED: DIMENSIONS ARE IN MILLIMETERS		PROPRIETARY AND CONFIDENTIAL THE INFORMATION CONTAINED IN THIS DRAWING IS THE SOLE PROPERTY OF SEE SECURITY PTY LTD. ANY REPRODUCTION IN PART OR AS A WHOLE WITHOUT THE WRITTEN PERMISSION OF SEE SECURITY PTY LTD IS PROHIBITED.		DEBUR AND BREAK SHARP EDGES	DO NOT SCALE DRAWING	REVISION
FINISH:		NAME SIGNATURE DATE				A3
DRAWN ADC		14/10/2016				
MATERIAL: Steel/stainless steel		Weight 11kg		DWG NO. SB00762A01		SCALE:1:5
						SHEET 62 OF 84

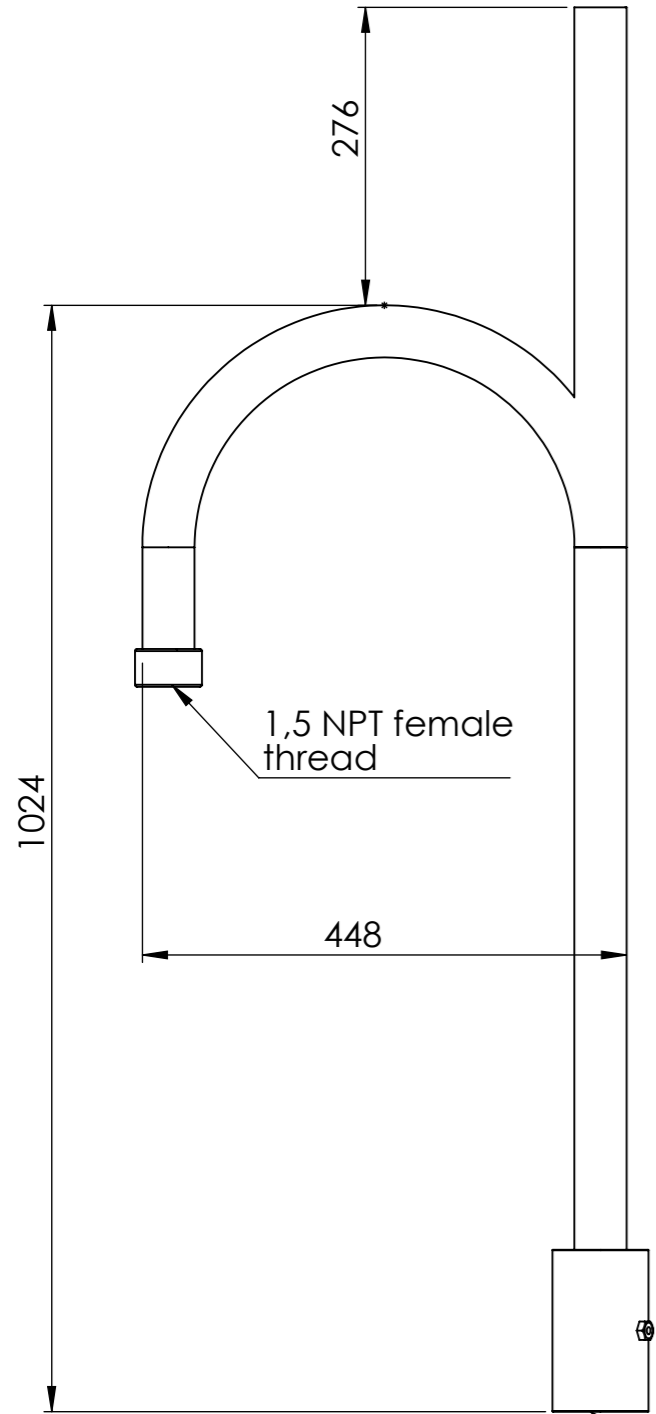
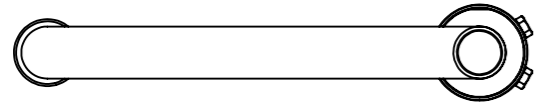

to suit 76.1 spigot

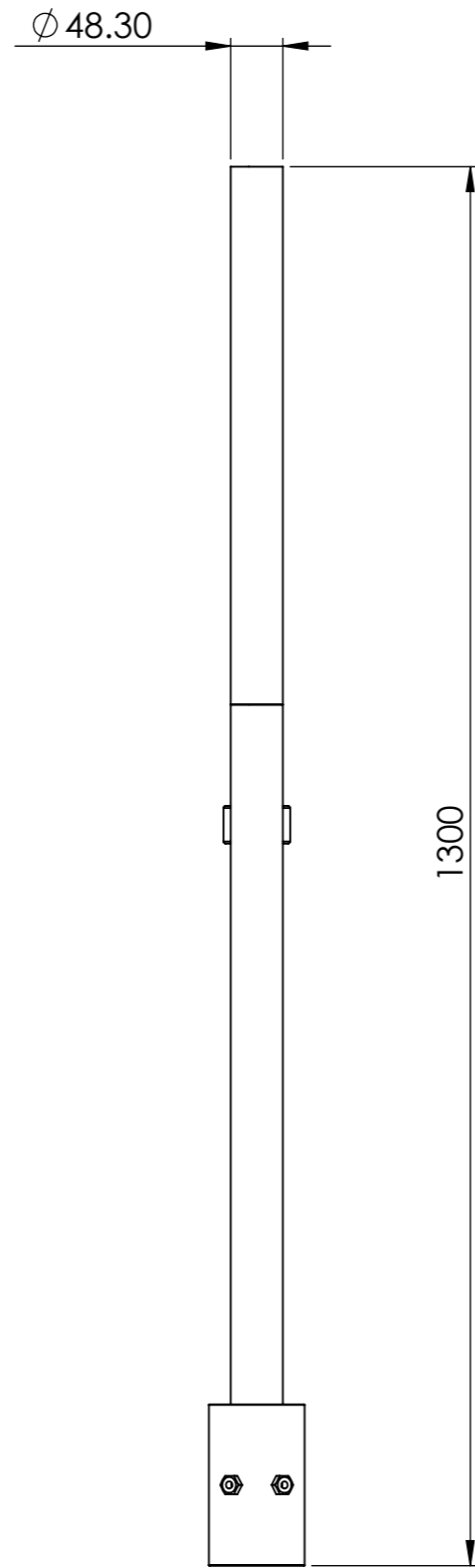

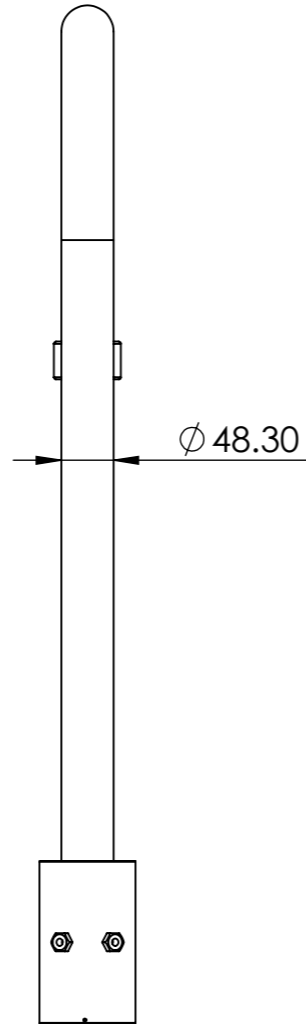
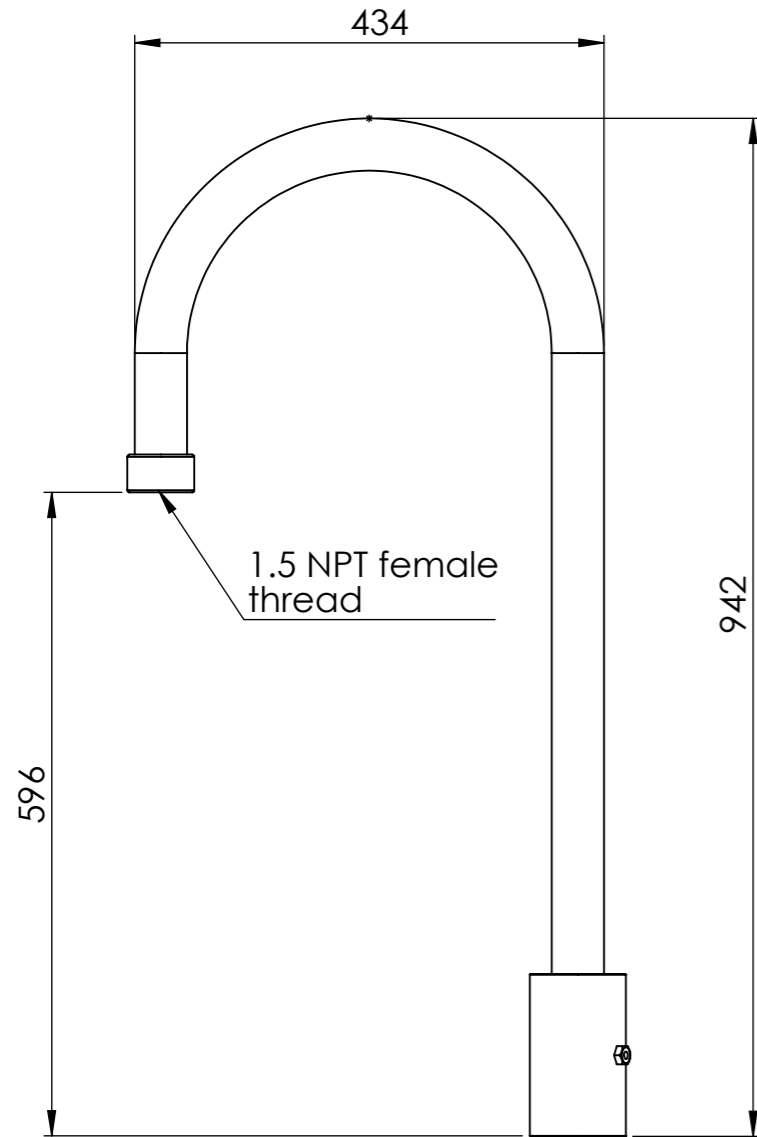
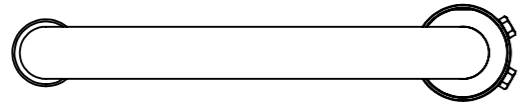

UNLESS OTHERWISE SPECIFIED: DIMENSIONS ARE IN MILLIMETERS		PROPRIETARY AND CONFIDENTIAL THE INFORMATION CONTAINED IN THIS DRAWING IS THE SOLE PROPERTY OF SEE SECURITY PTY LTD. ANY REPRODUCTION IN PART OR AS A WHOLE WITHOUT THE WRITTEN PERMISSION OF SEE SECURITY PTY LTD IS PROHIBITED.		DEBUR AND BREAK SHARP EDGES	DO NOT SCALE DRAWING	REVISION
FINISH:		NAME SIGNATURE DATE				A3
DRAWN ADC		14/10/2016				
MATERIAL: Steel		Weight 7kg		DWG NO. SB00762A07		SCALE:1:5
				SHEET 63 OF 84		



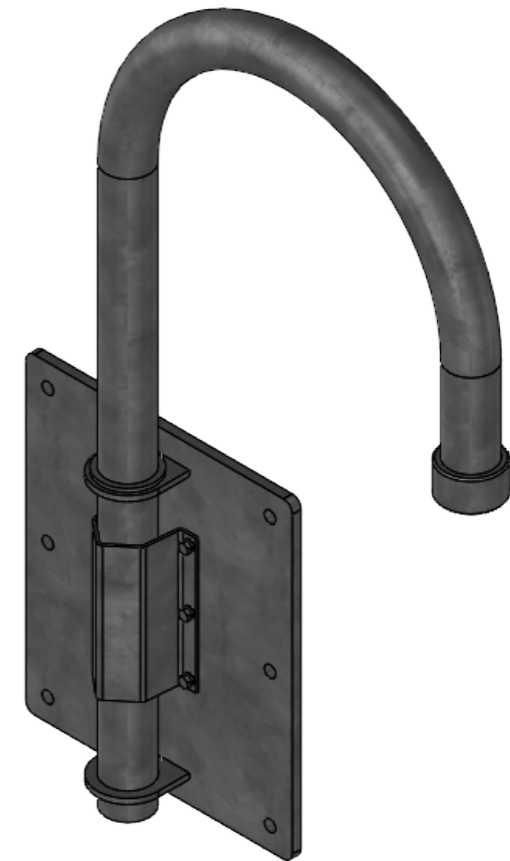
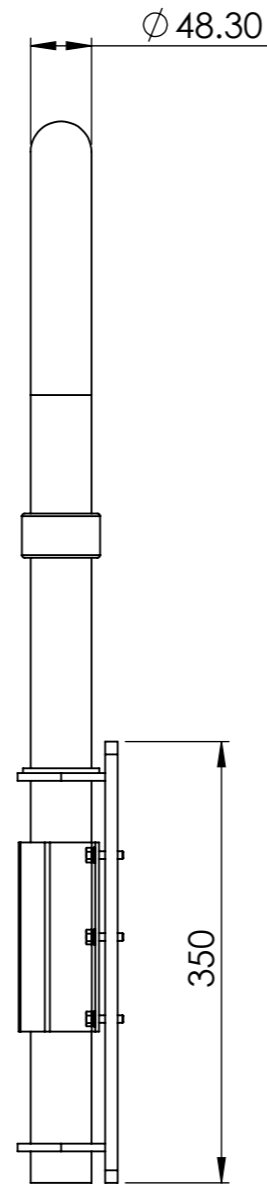
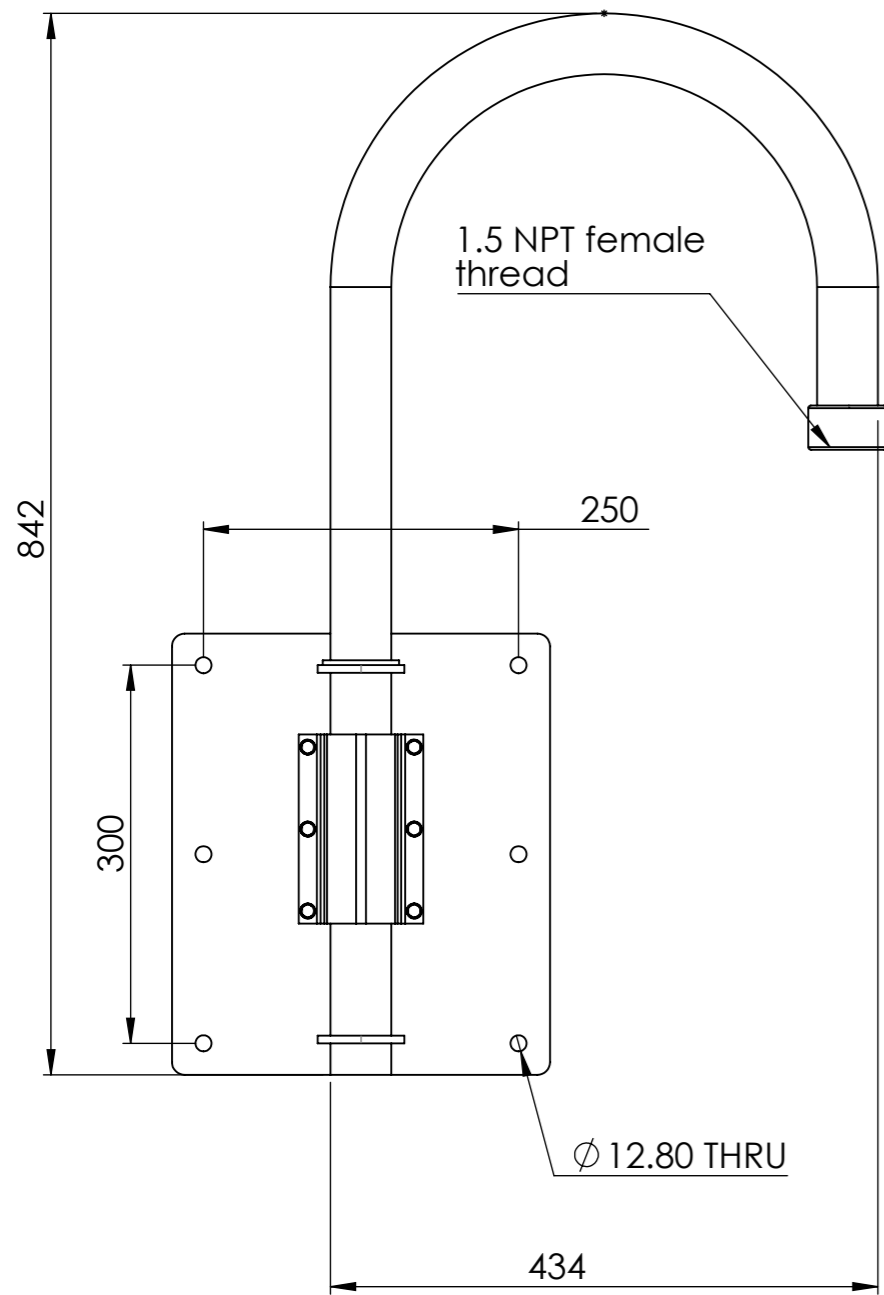
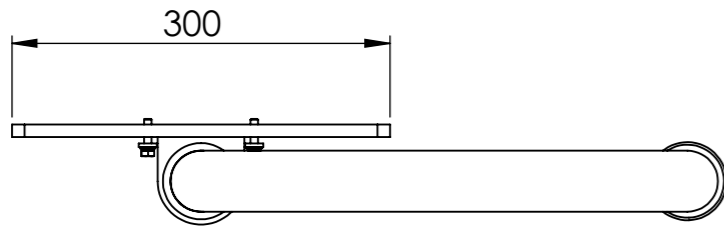

to suit 76.1 spigot

UNLESS OTHERWISE SPECIFIED: DIMENSIONS ARE IN MILLIMETERS		PROPRIETARY AND CONFIDENTIAL THE INFORMATION CONTAINED IN THIS DRAWING IS THE SOLE PROPERTY OF SEE SECURITY PTY LTD. ANY REPRODUCTION IN PART OR AS A WHOLE WITHOUT THE WRITTEN PERMISSION OF SEE SECURITY PTY LTD IS PROHIBITED.		DEBUR AND BREAK SHARP EDGES	DO NOT SCALE DRAWING	REVISION
FINISH:		NAME SIGNATURE DATE				A3
DRAWN ADC		14/10/2016				
MATERIAL: Steel		Weight 6.5kg		DWG NO. SB00762A08		SCALE:1:5
				SHEET 64 OF 84		

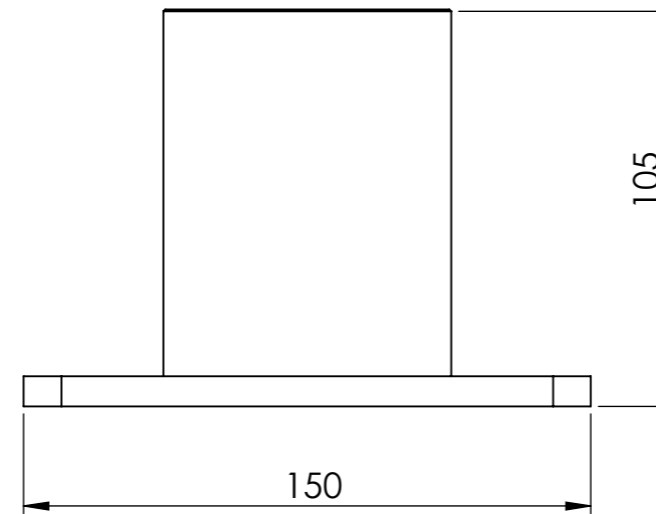
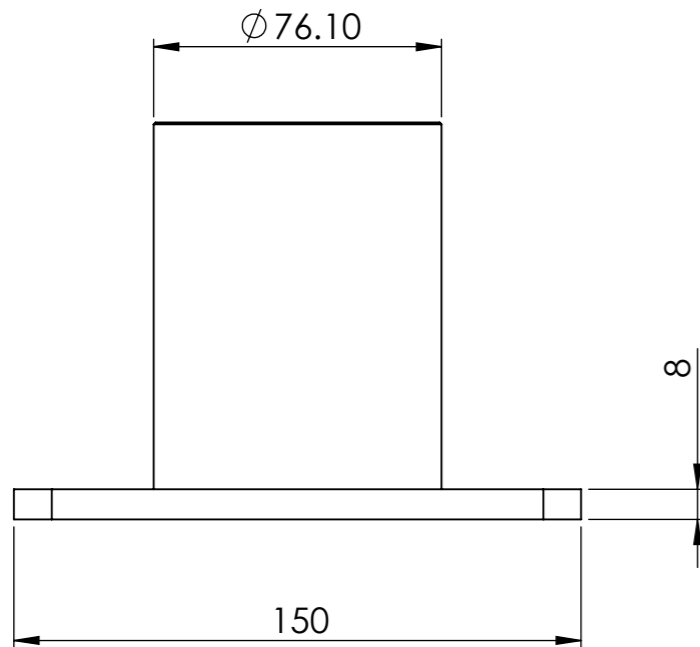
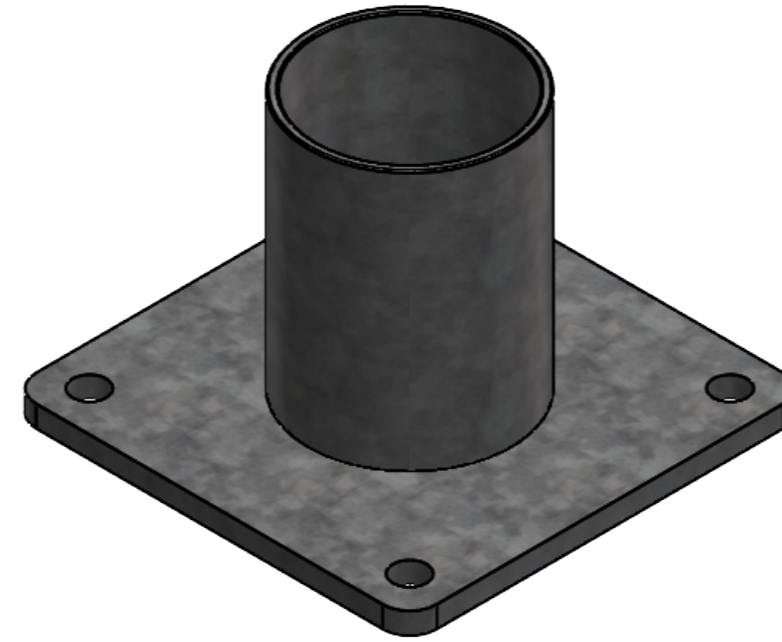
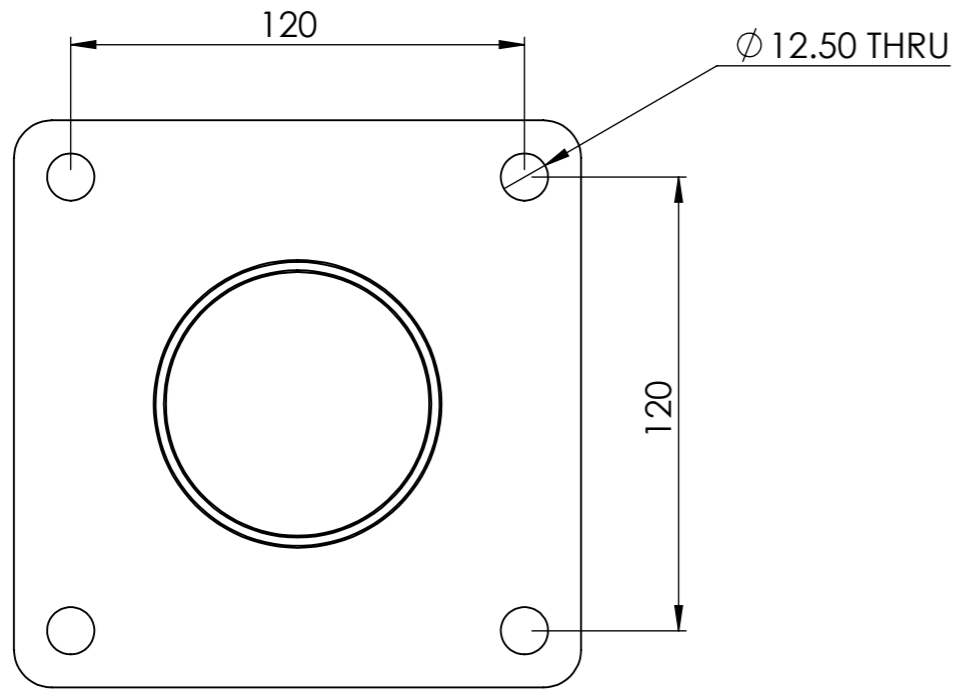

UNLESS OTHERWISE SPECIFIED: DIMENSIONS ARE IN MILLIMETERS		PROPRIETARY AND CONFIDENTIAL THE INFORMATION CONTAINED IN THIS DRAWING IS THE SOLE PROPERTY OF SEE SECURITY PTY LTD. ANY REPRODUCTION IN PART OR AS A WHOLE WITHOUT THE WRITTEN PERMISSION OF SEE SECURITY PTY LTD IS PROHIBITED.		DEBUR AND BREAK SHARP EDGES	DO NOT SCALE DRAWING	REVISION
FINISH:		NAME SIGNATURE DATE		 SEE SECURITY SECURITY & EQUIPMENT END OFFICES		A3
DRAWN ADC		14/10/2016				
MATERIAL: Steel		Weight 14kg		DWG NO. SB00762A09		SCALE:1:5
				SHEET 65 OF 84		



UNLESS OTHERWISE SPECIFIED: DIMENSIONS ARE IN MILLIMETERS		PROPRIETARY AND CONFIDENTIAL THE INFORMATION CONTAINED IN THIS DRAWING IS THE SOLE PROPERTY OF SEE SECURITY PTY LTD. ANY REPRODUCTION IN PART OR AS A WHOLE WITHOUT THE WRITTEN PERMISSION OF SEE SECURITY PTY LTD IS PROHIBITED.		DEBUR AND BREAK SHARP EDGES	DO NOT SCALE DRAWING	REVISION
FINISH:		NAME SIGNATURE DATE				A3
DRAWN ADC		14/10/2016				
MATERIAL: Steel		Weight 1.7kg		DWG NO. SB00762A10		
				SCALE:1:5		SHEET 66 OF 84

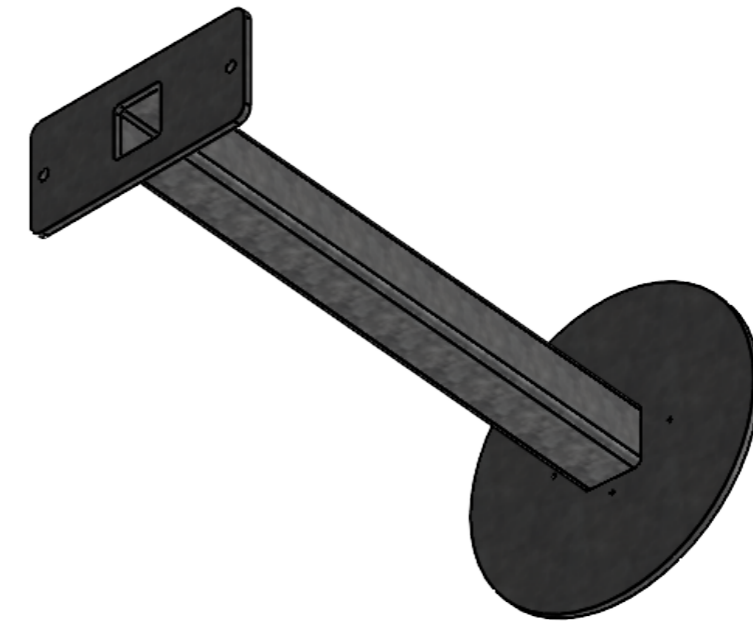
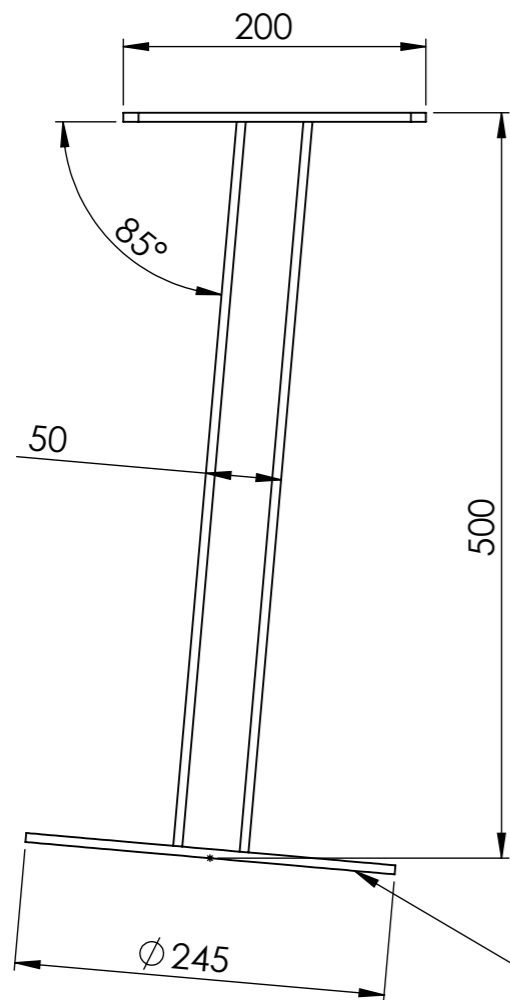
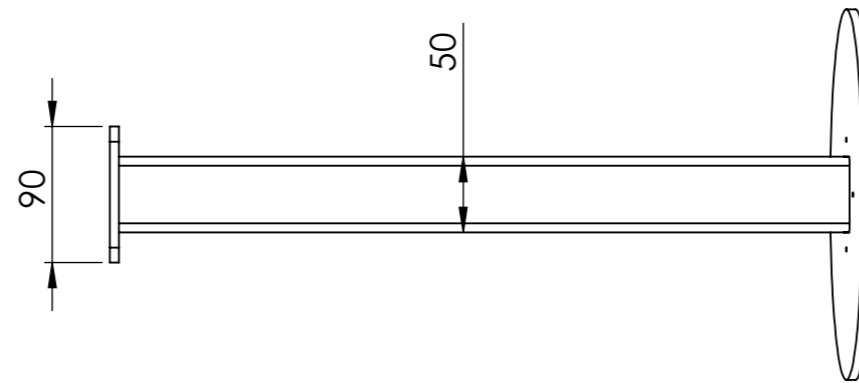
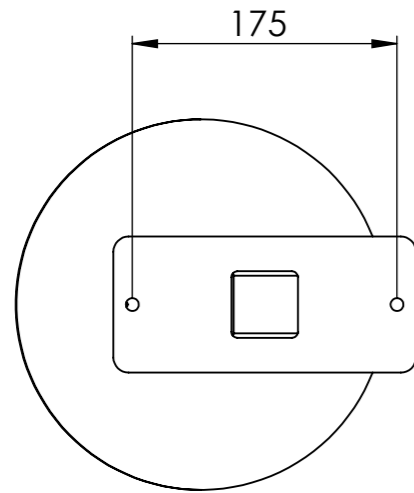

UNLESS OTHERWISE SPECIFIED: DIMENSIONS ARE IN MILLIMETERS	PROPRIETARY AND CONFIDENTIAL THE INFORMATION CONTAINED IN THIS DRAWING IS THE SOLE PROPERTY OF SEE SECURITY PTY LTD. ANY REPRODUCTION IN PART OR AS A WHOLE WITHOUT THE WRITTEN PERMISSION OF SEE SECURITY PTY LTD IS PROHIBITED.	DEBUR AND BREAK SHARP EDGES	DO NOT SCALE DRAWING	REVISION
FINISH:			 SEE SECURITY SECURITY & EQUIPMENT END SOLUTIONS	
NAME	SIGNATURE	DATE		
DRAWN	ADC	14/10/2016	DWG NO.	A3
MATERIAL:	Weight		SHEET 67 OF 84	
Steel galvanised	5kg		SCALE:1:5	

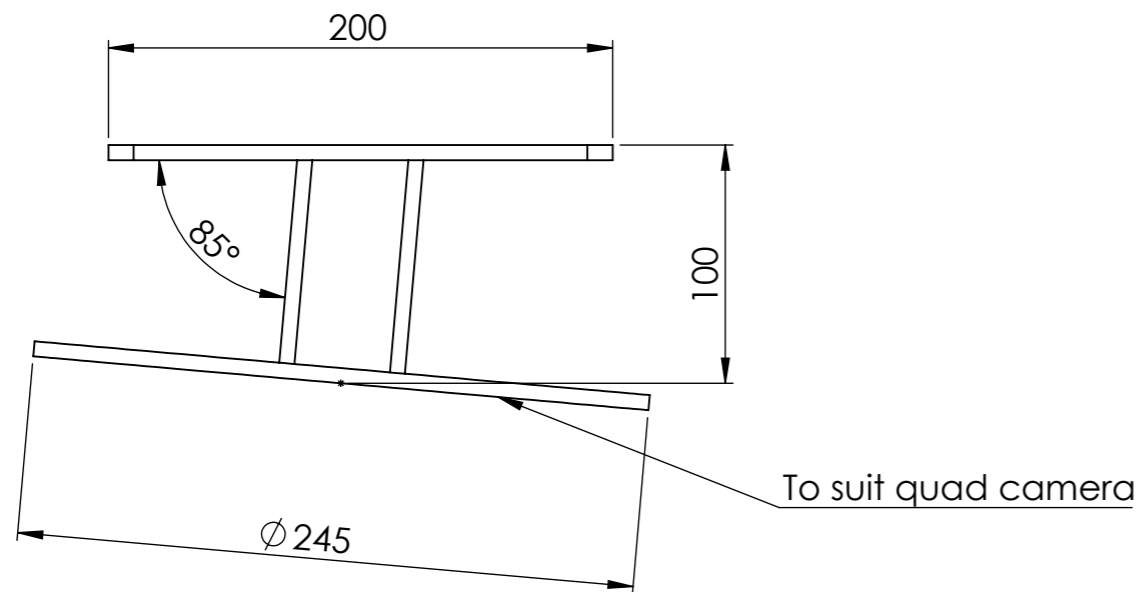
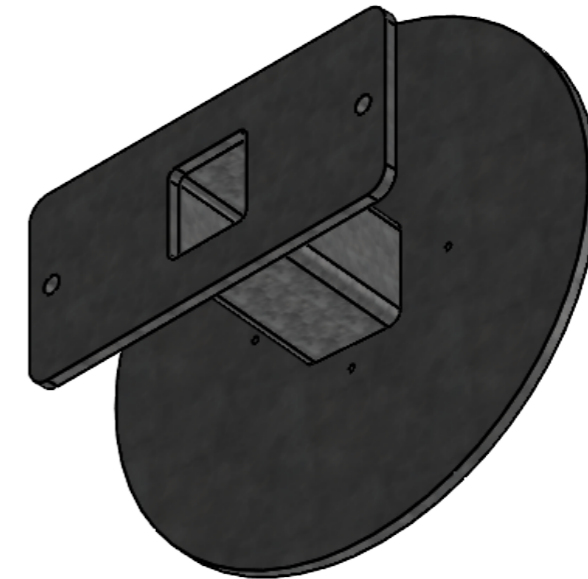
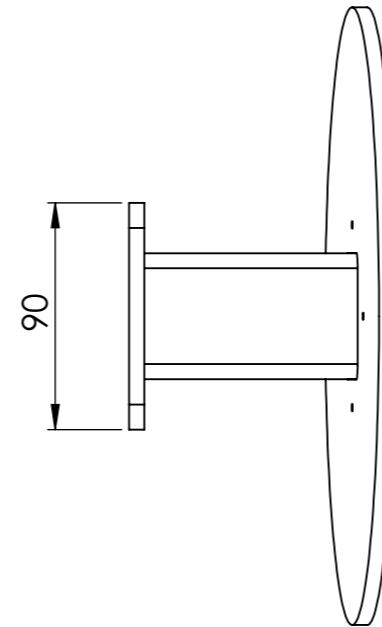
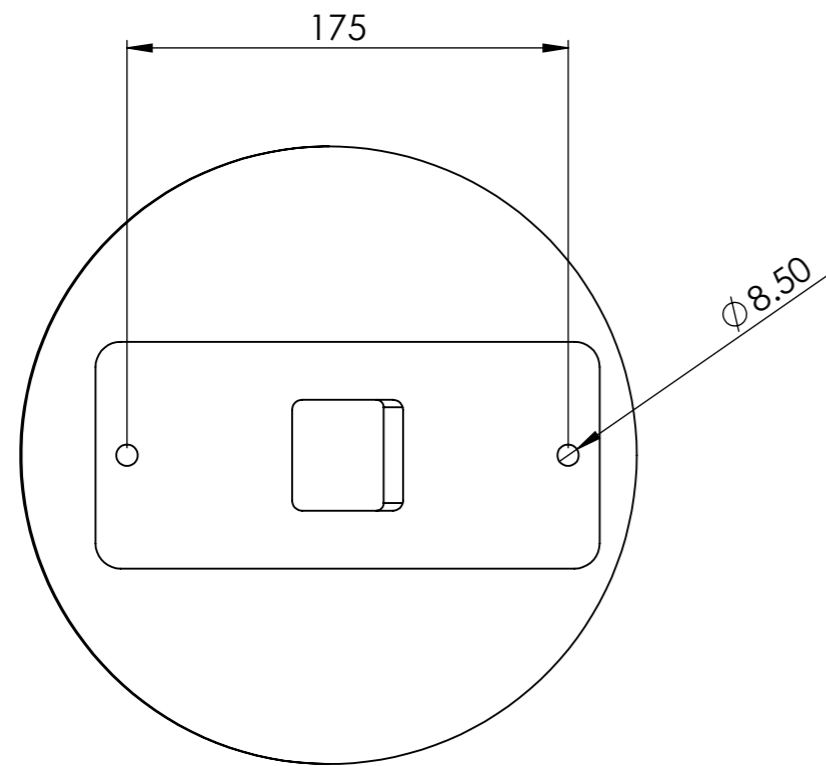

UNLESS OTHERWISE SPECIFIED: DIMENSIONS ARE IN MILLIMETERS	PROPRIETARY AND CONFIDENTIAL THE INFORMATION CONTAINED IN THIS DRAWING IS THE SOLE PROPERTY OF SEE SECURITY PTY LTD. ANY REPRODUCTION IN PART OR AS A WHOLE WITHOUT THE WRITTEN PERMISSION OF SEE SECURITY PTY LTD IS PROHIBITED.	DEBUR AND BREAK SHARP EDGES	DO NOT SCALE DRAWING	REVISION
FINISH:				
NAME	SIGNATURE	DATE		
DRAWN	ADC	14/10/2016		
MATERIAL: Steel galvanised	Weight 3.2 kg	DWG NO. SB00776A02		A3
		SCALE:1:5	SHEET 68 OF 84	

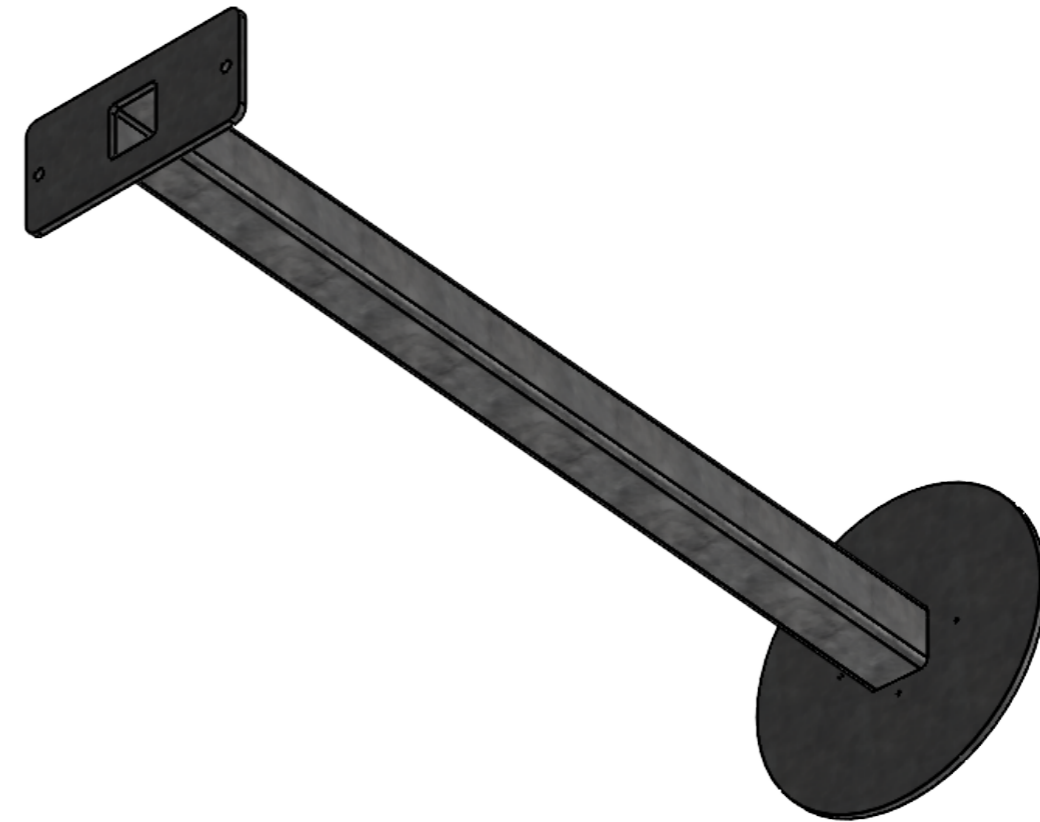
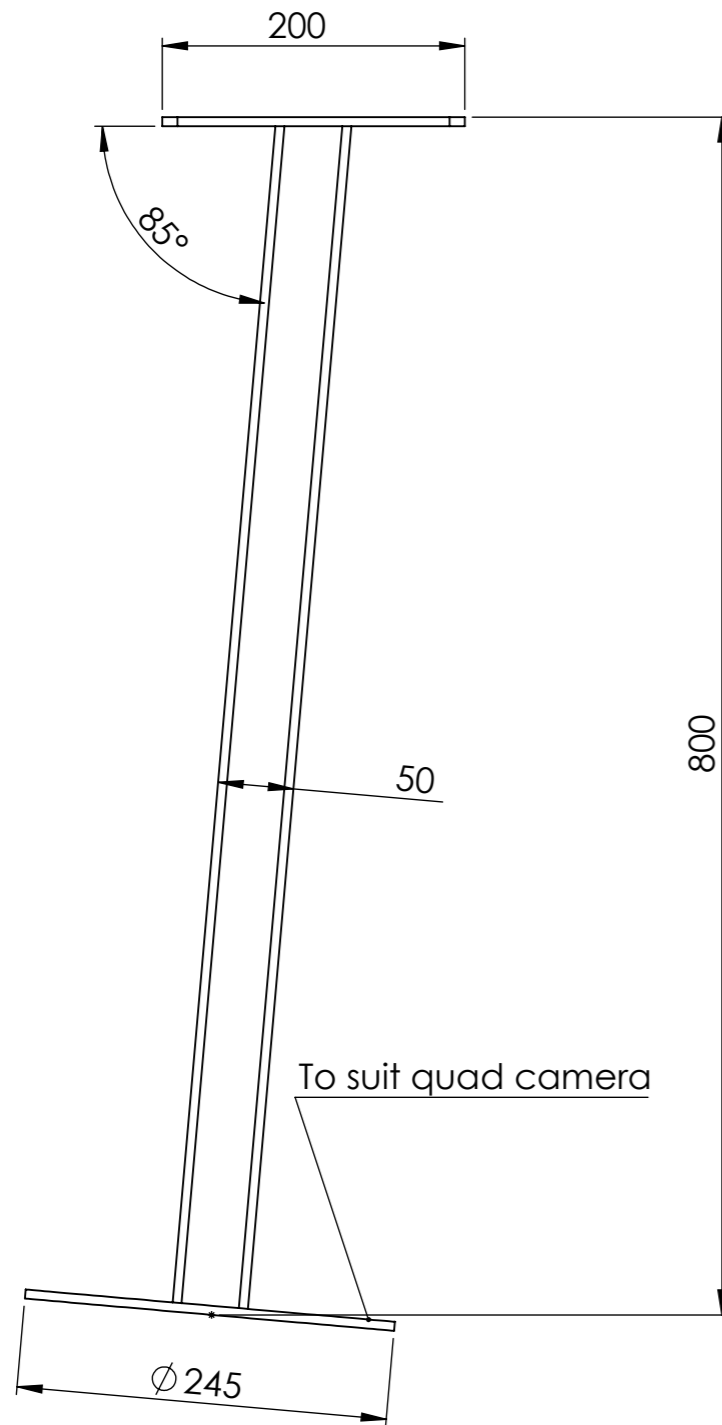
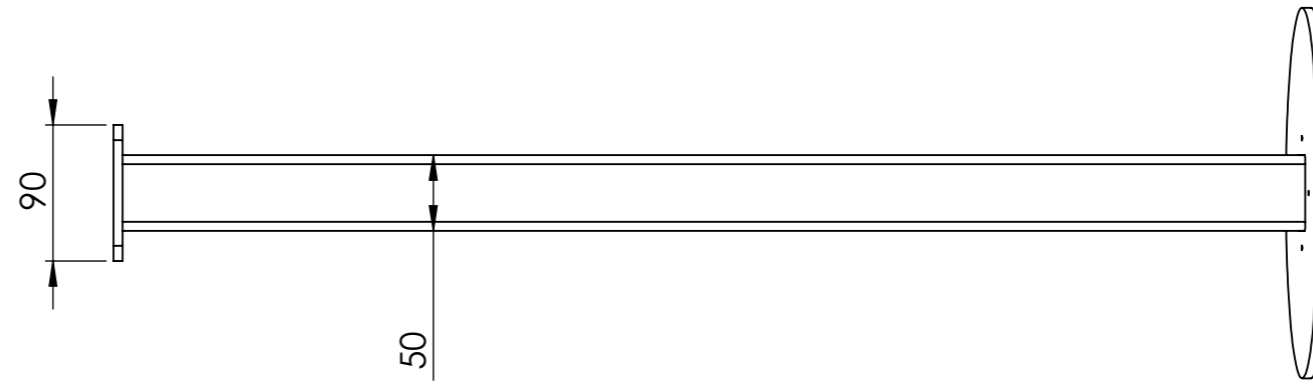
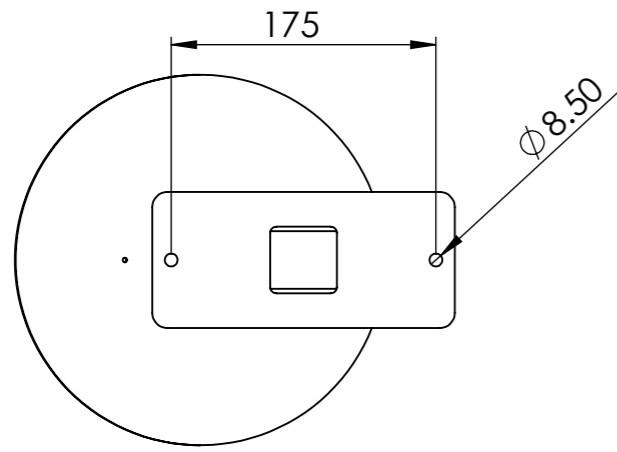

UNLESS OTHERWISE SPECIFIED: DIMENSIONS ARE IN MILLIMETERS	PROPRIETARY AND CONFIDENTIAL THE INFORMATION CONTAINED IN THIS DRAWING IS THE SOLE PROPERTY OF SEE SECURITY PTY LTD. ANY REPRODUCTION IN PART OR AS A WHOLE WITHOUT THE WRITTEN PERMISSION OF SEE SECURITY PTY LTD IS PROHIBITED.	DEBUR AND BREAK SHARP EDGES	DO NOT SCALE DRAWING	REVISION
FINISH:			 SEE SECURITY SECURITY & EQUIPMENT END. OFFERS	
NAME	SIGNATURE	DATE		
DRAWN	ADC	14/10/2016	DWG NO.	A3
MATERIAL:	Weight	SB00776A03		
Steel galvanised	6.2kg	SCALE:1:5	SHEET 69 OF 84	

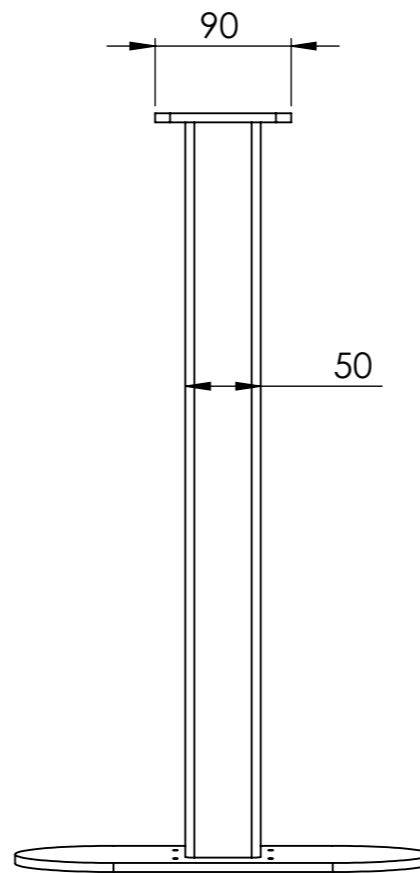
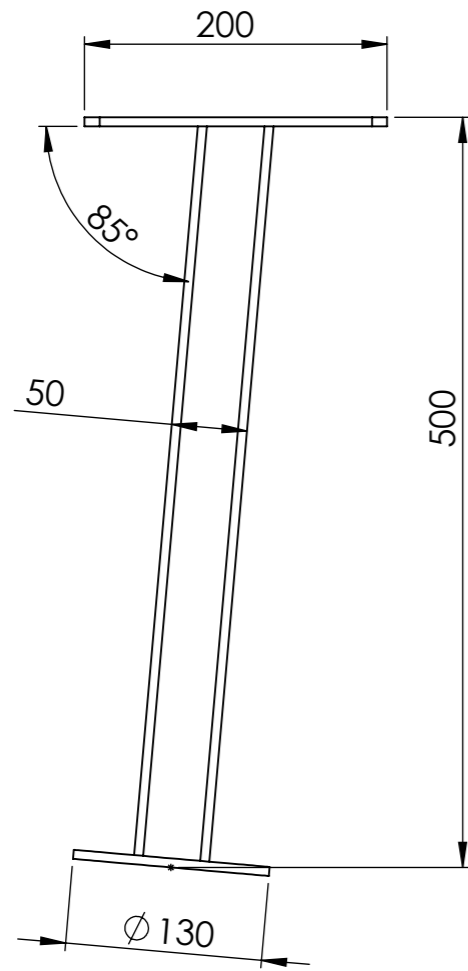
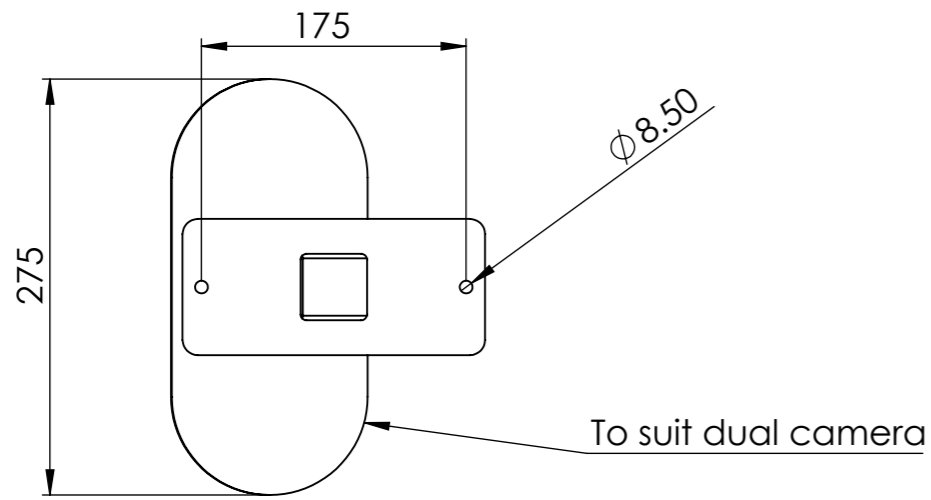

UNLESS OTHERWISE SPECIFIED: DIMENSIONS ARE IN MILLIMETERS	PROPRIETARY AND CONFIDENTIAL THE INFORMATION CONTAINED IN THIS DRAWING IS THE SOLE PROPERTY OF SEE SECURITY PTY LTD. ANY REPRODUCTION IN PART OR AS A WHOLE WITHOUT THE WRITTEN PERMISSION OF SEE SECURITY PTY LTD IS PROHIBITED.	DEBUR AND BREAK SHARP EDGES	DO NOT SCALE DRAWING	REVISION
FINISH:			 SEE SECURITY SECURITY & EQUIPMENT END. OFFERS	
NAME	SIGNATURE	DATE		
DRAWN	ADC	14/10/2016	DWG NO.	A3
MATERIAL:	Weight			
Steel galvanised	4.2kg		SB00776A04	
			SCALE:1:5	SHEET 70 OF 84

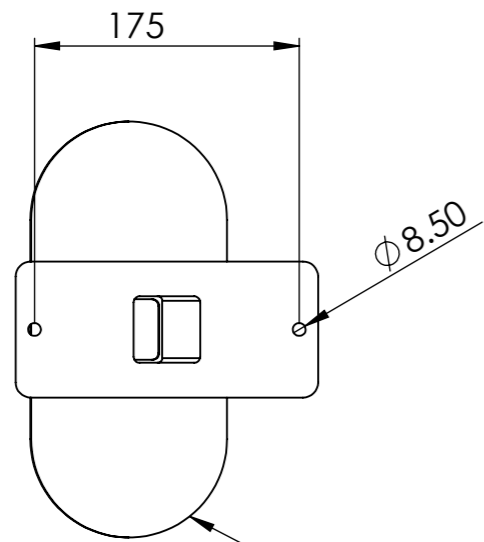

To suit dual cam

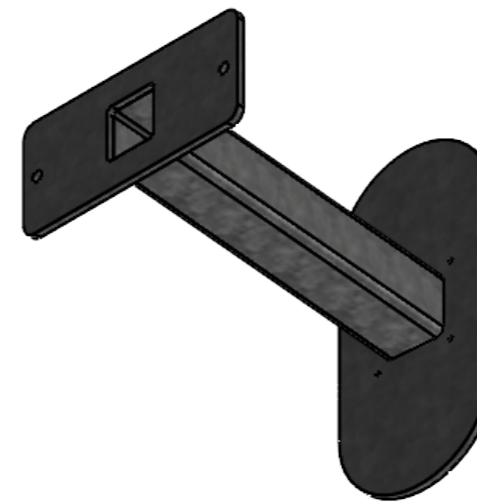
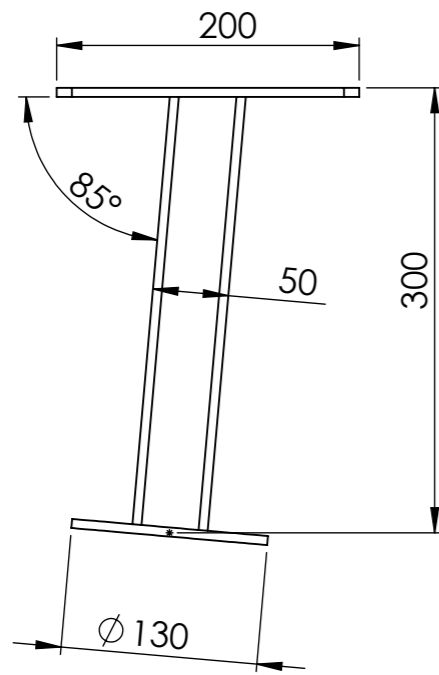
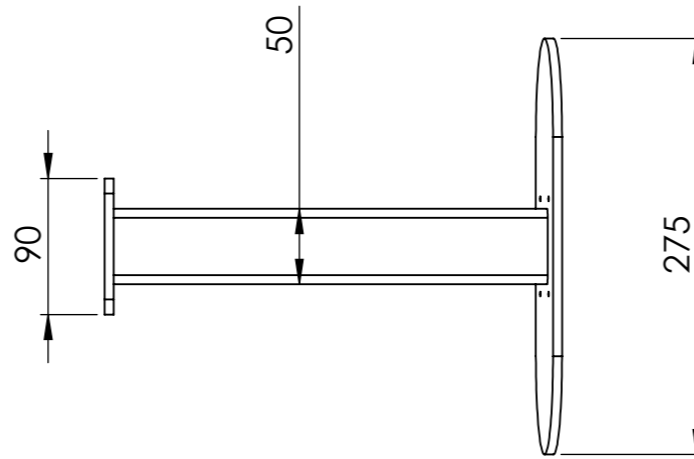

UNLESS OTHERWISE SPECIFIED: DIMENSIONS ARE IN MILLIMETERS	PROPRIETARY AND CONFIDENTIAL THE INFORMATION CONTAINED IN THIS DRAWING IS THE SOLE PROPERTY OF SEE SECURITY PTY LTD. ANY REPRODUCTION IN PART OR AS A WHOLE WITHOUT THE WRITTEN PERMISSION OF SEE SECURITY PTY LTD IS PROHIBITED.	DEBUR AND BREAK SHARP EDGES	DO NOT SCALE DRAWING	REVISION
FINISH:				
NAME	SIGNATURE	DATE		
DRAWN	ADC	14/10/2016		
MATERIAL:	Weight		DWG NO.	A3
Steel galvanised	3.4kg		SB00776A05	
			SCALE:1:5	SHEET 71 OF 84

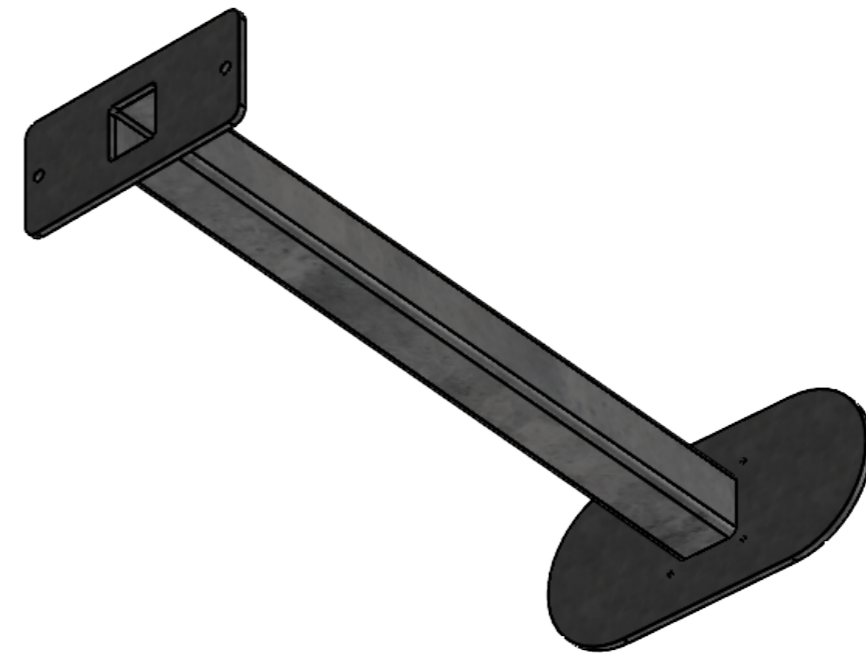
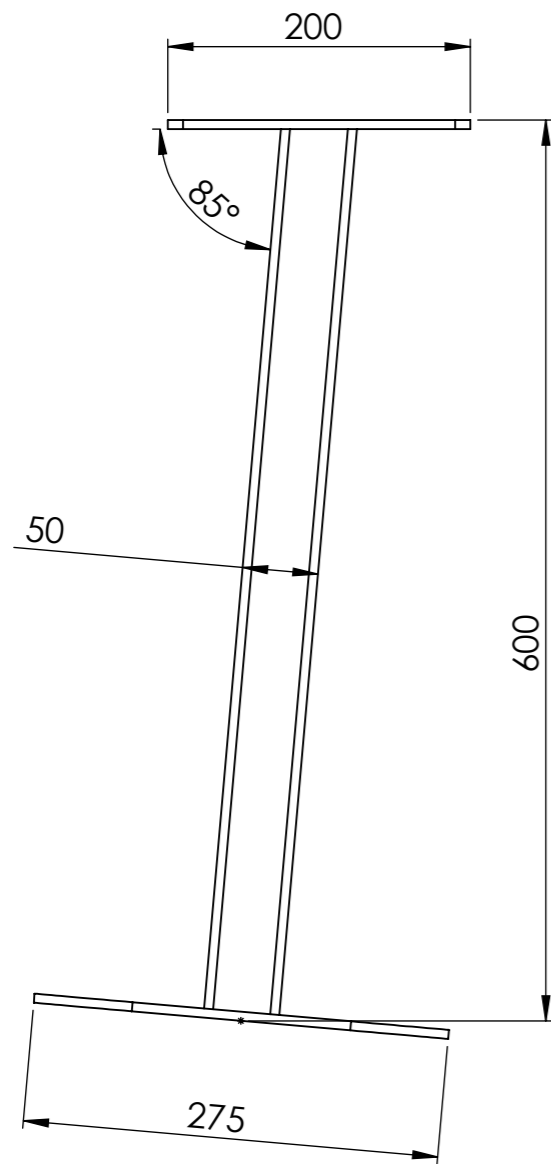
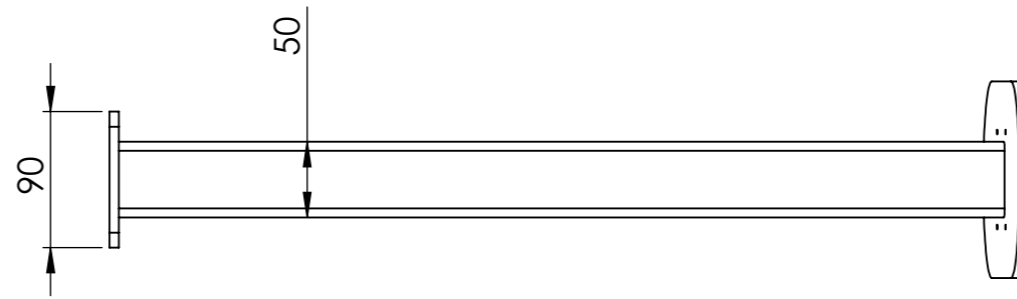
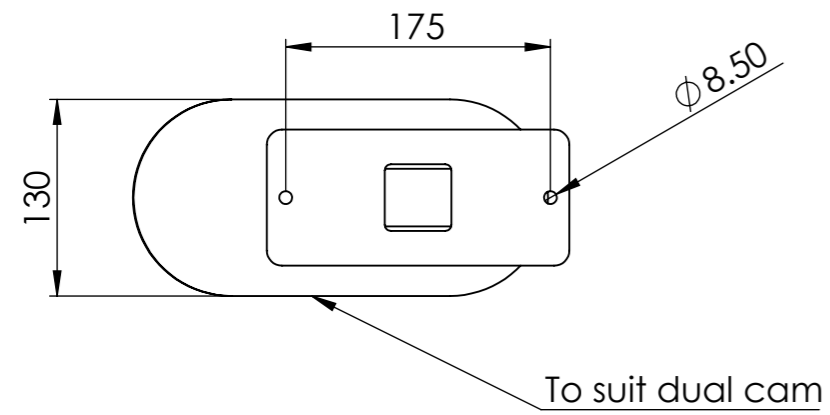

UNLESS OTHERWISE SPECIFIED: DIMENSIONS ARE IN MILLIMETERS	PROPRIETARY AND CONFIDENTIAL THE INFORMATION CONTAINED IN THIS DRAWING IS THE SOLE PROPERTY OF SEE SECURITY PTY LTD. ANY REPRODUCTION IN PART OR AS A WHOLE WITHOUT THE WRITTEN PERMISSION OF SEE SECURITY PTY LTD IS PROHIBITED.	DEBUR AND BREAK SHARP EDGES	DO NOT SCALE DRAWING	REVISION
FINISH:			 SEE SECURITY <small>SECURITY & EQUIPMENT END. OFFERS</small>	
NAME	SIGNATURE	DATE		
DRAWN	ADC	14/10/2016		
MATERIAL:	Weight	DWG NO.		A3
Steel galvanised	4.7kg	SB00776A06		
		SCALE:1:5	SHEET 72 OF 84	

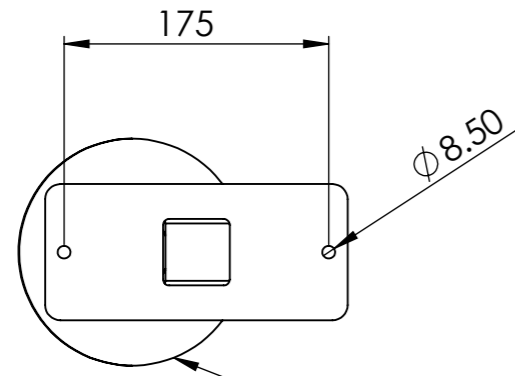

To suit dome camera

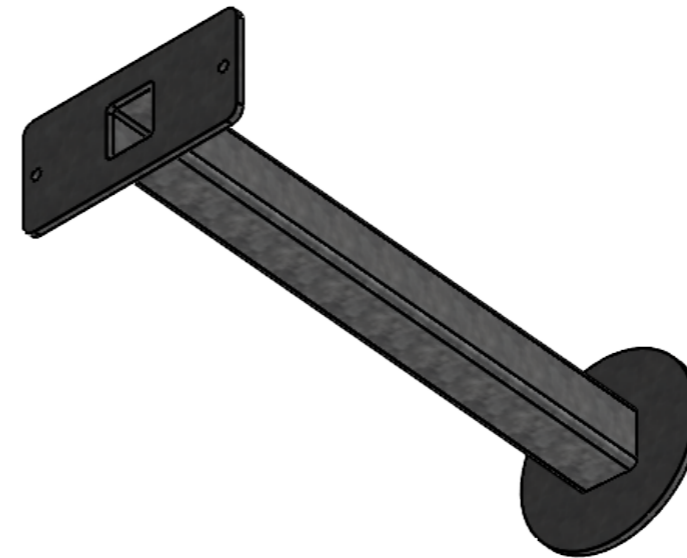
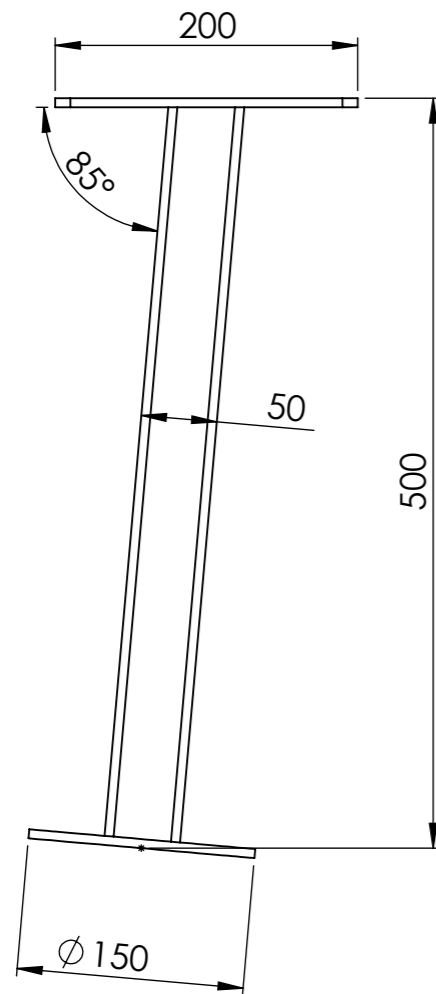
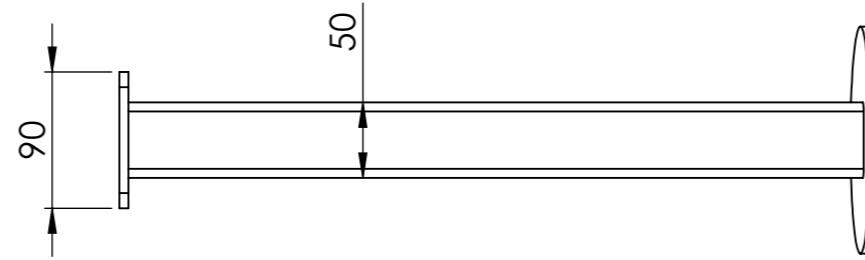

UNLESS OTHERWISE SPECIFIED: DIMENSIONS ARE IN MILLIMETERS	PROPRIETARY AND CONFIDENTIAL THE INFORMATION CONTAINED IN THIS DRAWING IS THE SOLE PROPERTY OF SEE SECURITY PTY LTD. ANY REPRODUCTION IN PART OR AS A WHOLE WITHOUT THE WRITTEN PERMISSION OF SEE SECURITY PTY LTD IS PROHIBITED.	DEBUR AND BREAK SHARP EDGES	DO NOT SCALE DRAWING	REVISION
FINISH:				
NAME	SIGNATURE	DATE		
DRAWN	ADC	14/10/2016	DWG NO.	A3
MATERIAL:	Weight			
Steel galvanised	3.6kg		SB00776A07	
			SCALE:1:5	SHEET 73 OF 84

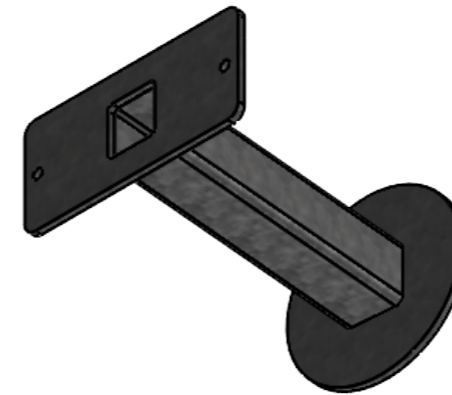
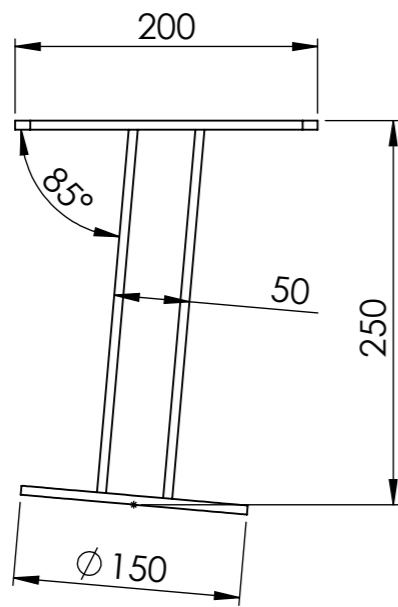
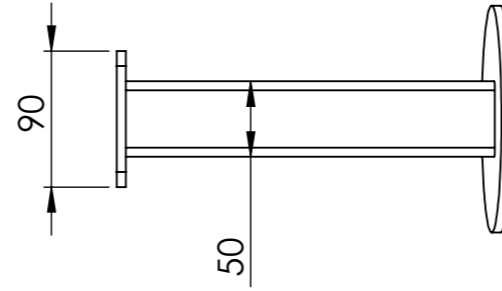
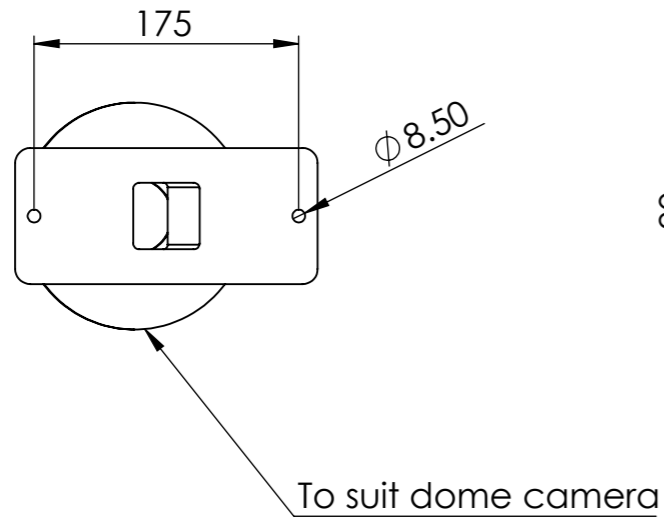

UNLESS OTHERWISE SPECIFIED: DIMENSIONS ARE IN MILLIMETERS	PROPRIETARY AND CONFIDENTIAL THE INFORMATION CONTAINED IN THIS DRAWING IS THE SOLE PROPERTY OF SEE SECURITY PTY LTD. ANY REPRODUCTION IN PART OR AS A WHOLE WITHOUT THE WRITTEN PERMISSION OF SEE SECURITY PTY LTD IS PROHIBITED.	DEBUR AND BREAK SHARP EDGES	DO NOT SCALE DRAWING	REVISION
FINISH:			 SEE SECURITY SECURITY & EQUIPMENT END. OFFERS	
NAME	SIGNATURE	DATE		
DRAWN	ADC	14/10/2016		
MATERIAL:	Weight	DWG NO.		
Steel galvanised	2.5kg	SB00776A08		A3
		SCALE:1:5	SHEET 74 OF 84	

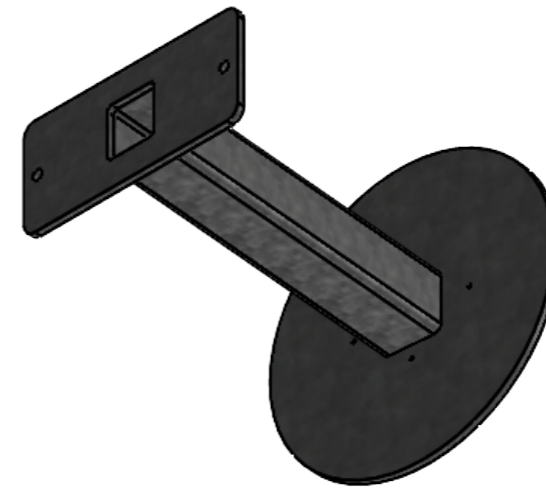
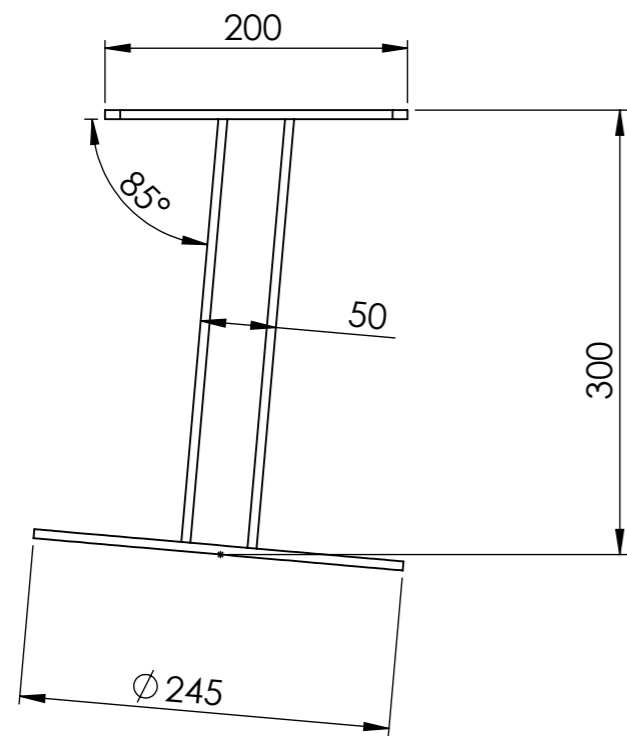
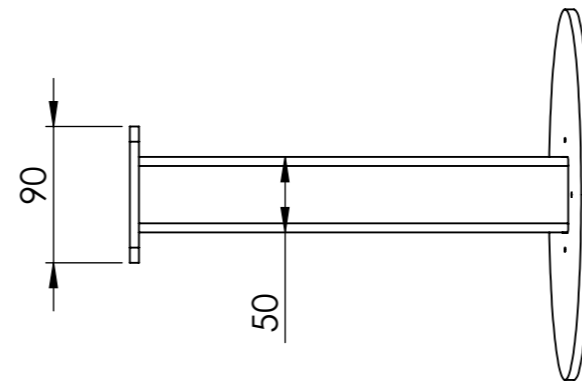
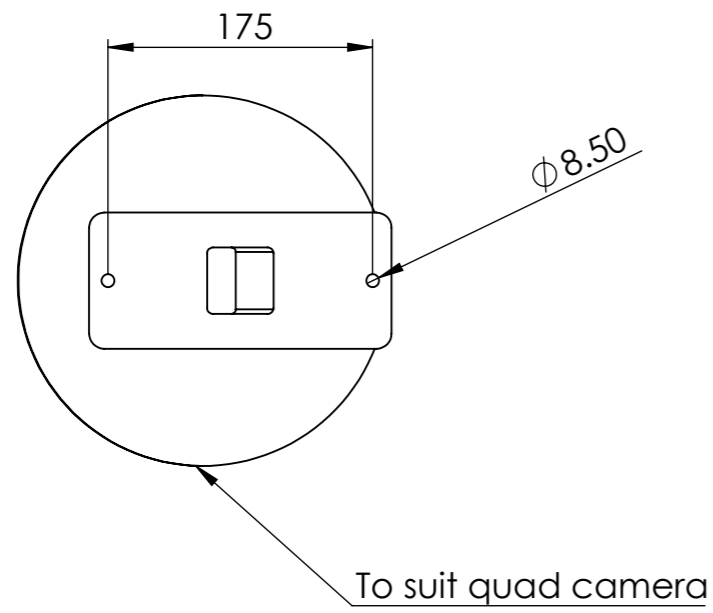

UNLESS OTHERWISE SPECIFIED: DIMENSIONS ARE IN MILLIMETERS	PROPRIETARY AND CONFIDENTIAL THE INFORMATION CONTAINED IN THIS DRAWING IS THE SOLE PROPERTY OF SEE SECURITY PTY LTD. ANY REPRODUCTION IN PART OR AS A WHOLE WITHOUT THE WRITTEN PERMISSION OF SEE SECURITY PTY LTD IS PROHIBITED.	DEBUR AND BREAK SHARP EDGES	DO NOT SCALE DRAWING	REVISION
FINISH:			 SEE SECURITY SECURITY & EQUIPMENT ENG. SERVICES	
NAME	SIGNATURE	DATE		
DRAWN	ADC	14/10/2016	DWG NO.	A3
MATERIAL:	Weight		SB00776A09	
Steel galvanised	4.1kg		SCALE:1:5	SHEET 75 OF 84

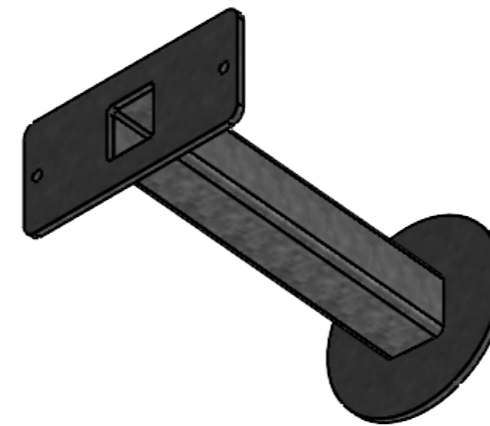
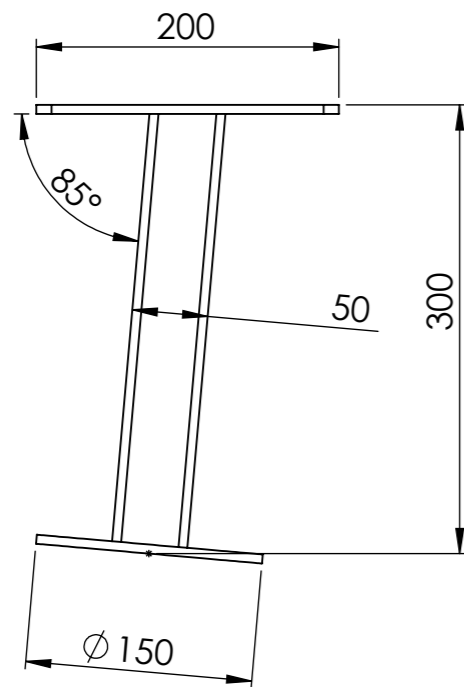
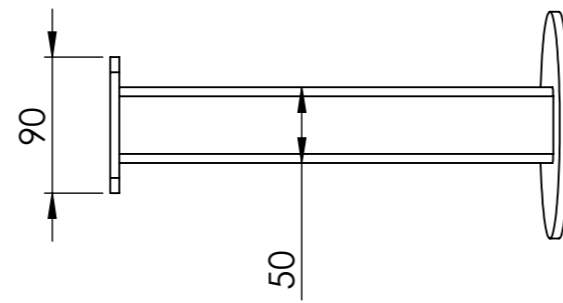
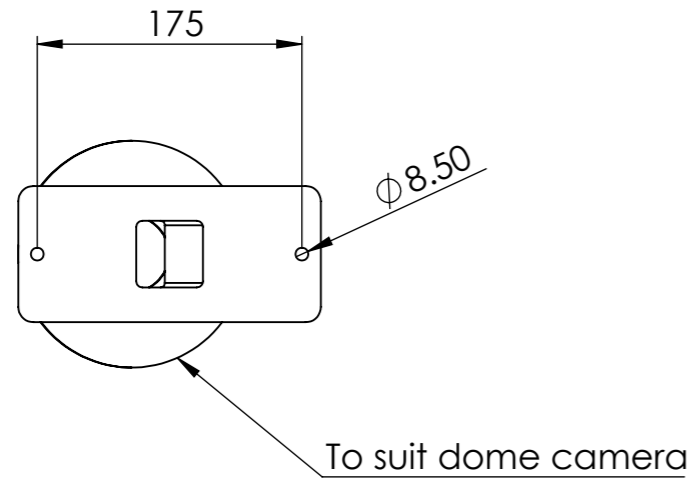

UNLESS OTHERWISE SPECIFIED: DIMENSIONS ARE IN MILLIMETERS	PROPRIETARY AND CONFIDENTIAL THE INFORMATION CONTAINED IN THIS DRAWING IS THE SOLE PROPERTY OF SEE SECURITY PTY LTD. ANY REPRODUCTION IN PART OR AS A WHOLE WITHOUT THE WRITTEN PERMISSION OF SEE SECURITY PTY LTD IS PROHIBITED.	DEBUR AND BREAK SHARP EDGES	DO NOT SCALE DRAWING	REVISION
FINISH:				
NAME	SIGNATURE	DATE		
DRAWN	ADC	14/10/2016		
MATERIAL:	Weight	DWG NO.		A3
Steel galvanised	2.7kg	SB00776A10		
		SCALE:1:5	SHEET 76 OF 84	

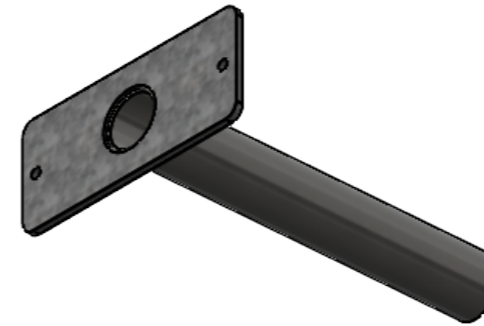
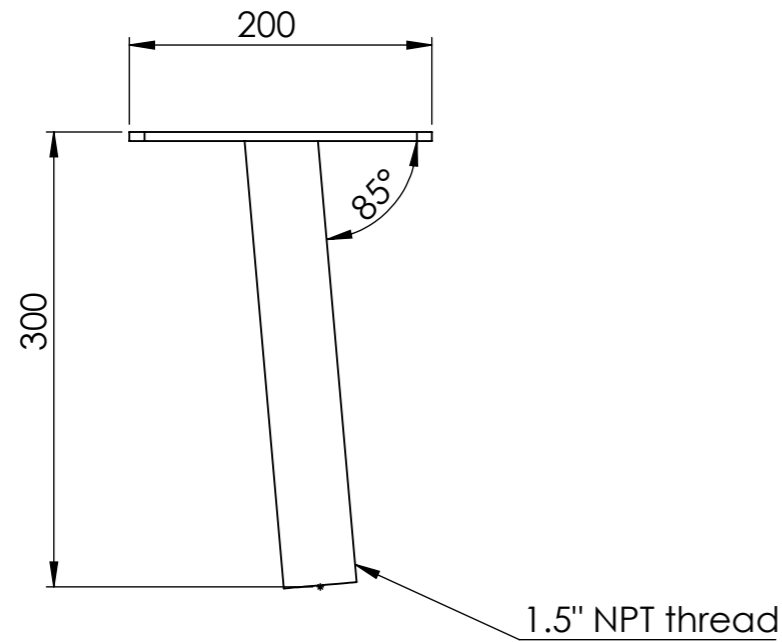
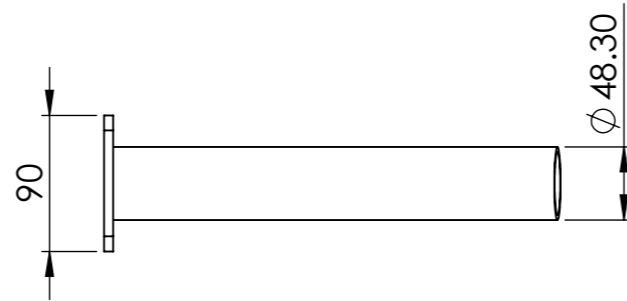
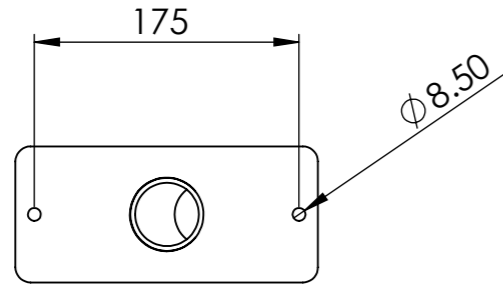

UNLESS OTHERWISE SPECIFIED: DIMENSIONS ARE IN MILLIMETERS	PROPRIETARY AND CONFIDENTIAL THE INFORMATION CONTAINED IN THIS DRAWING IS THE SOLE PROPERTY OF SEE SECURITY PTY LTD. ANY REPRODUCTION IN PART OR AS A WHOLE WITHOUT THE WRITTEN PERMISSION OF SEE SECURITY PTY LTD IS PROHIBITED.	DEBUR AND BREAK SHARP EDGES	DO NOT SCALE DRAWING	REVISION
FINISH:				
NAME	SIGNATURE	DATE		
DRAWN	ADC	14/10/2016	DWG NO.	A3
MATERIAL:	Weight		SB00776A11	
Steel galvanised	1.8kg		SCALE:1:5	SHEET 77 OF 84

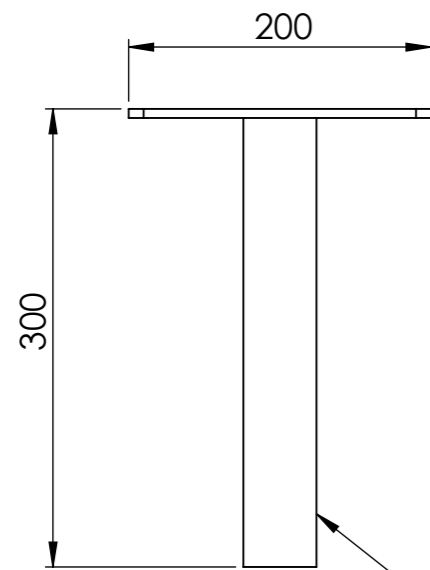
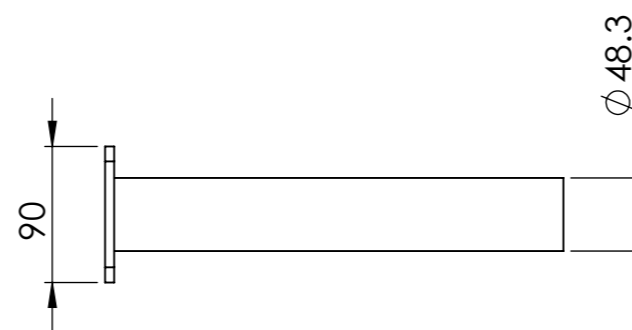
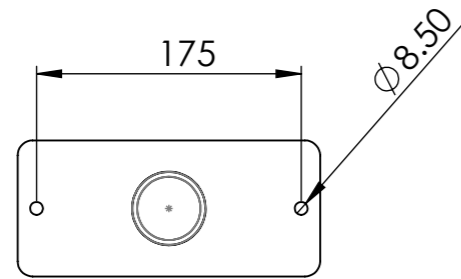

1.5" NPT thread

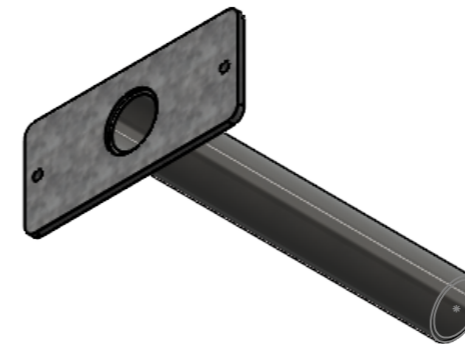

UNLESS OTHERWISE SPECIFIED: DIMENSIONS ARE IN MILLIMETERS		PROPRIETARY AND CONFIDENTIAL THE INFORMATION CONTAINED IN THIS DRAWING IS THE SOLE PROPERTY OF SEE SECURITY PTY LTD. ANY REPRODUCTION IN PART OR AS A WHOLE WITHOUT THE WRITTEN PERMISSION OF SEE SECURITY PTY LTD IS PROHIBITED.		DEBUR AND BREAK SHARP EDGES	DO NOT SCALE DRAWING	REVISION
FINISH:		NAME SIGNATURE DATE				A3
DRAWN ADC		14/10/2016				
MATERIAL: Steel galvanised		Weight 1.8kg		DWG NO. SB00776A12		
				SCALE:1:5		SHEET 78 OF 84

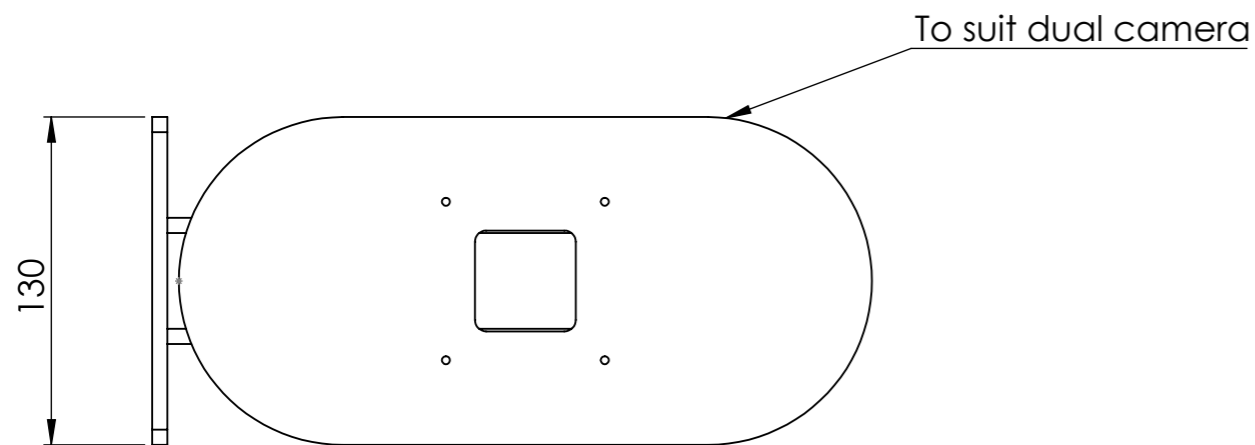
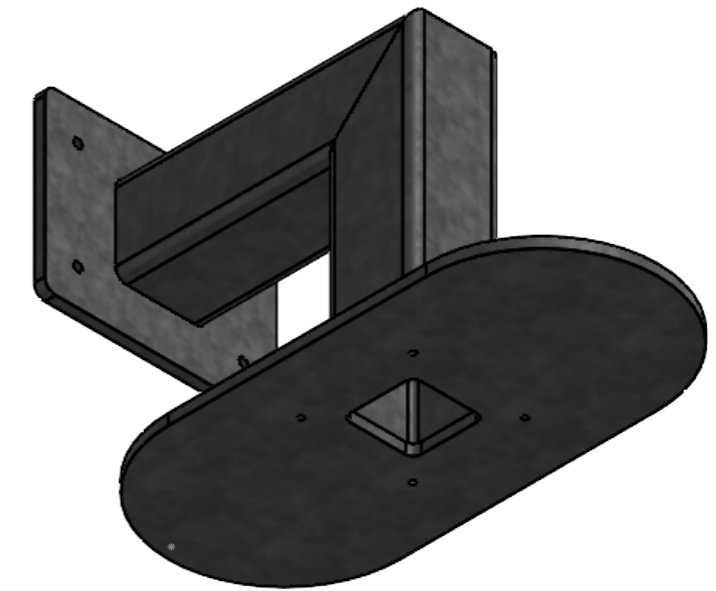
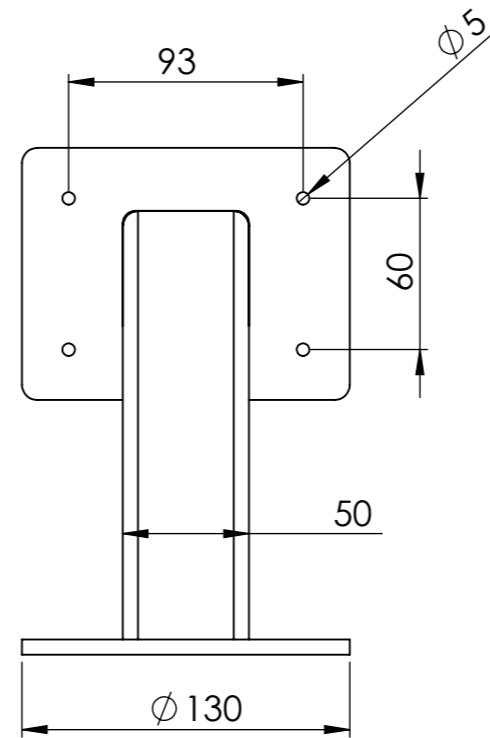
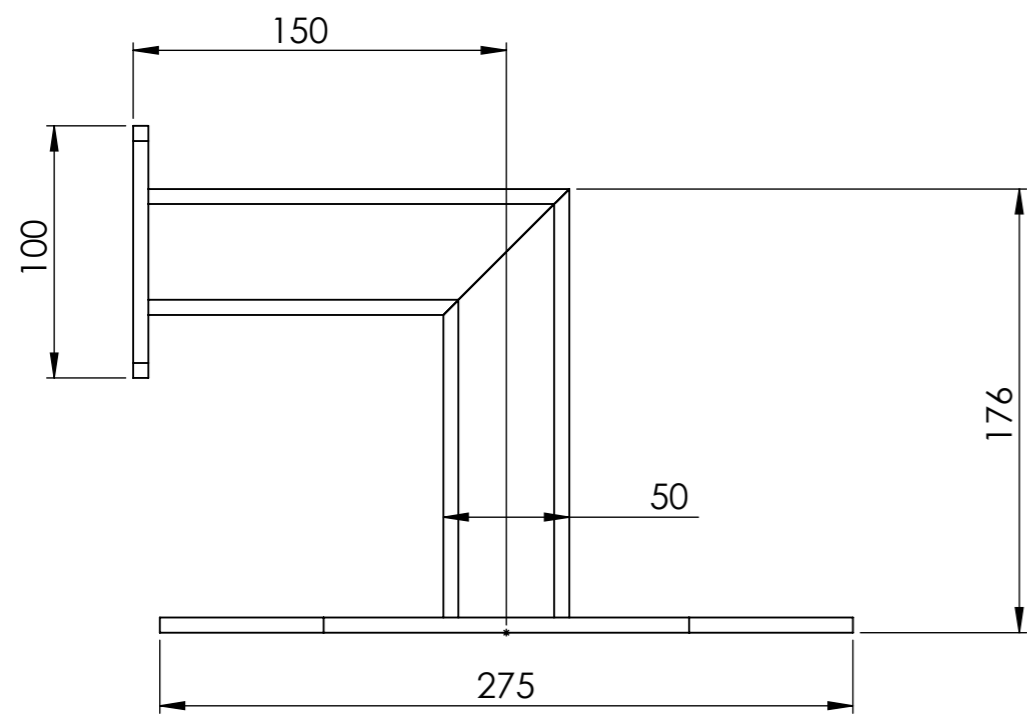

UNLESS OTHERWISE SPECIFIED: DIMENSIONS ARE IN MILLIMETERS	PROPRIETARY AND CONFIDENTIAL THE INFORMATION CONTAINED IN THIS DRAWING IS THE SOLE PROPERTY OF SEE SECURITY PTY LTD. ANY REPRODUCTION IN PART OR AS A WHOLE WITHOUT THE WRITTEN PERMISSION OF SEE SECURITY PTY LTD IS PROHIBITED.	DEBUR AND BREAK SHARP EDGES	DO NOT SCALE DRAWING	REVISION
FINISH:			 SEE SECURITY SECURITY & EQUIPMENT END USERS	
NAME	SIGNATURE	DATE		
DRAWN	ADC	14/10/2016	DWG NO.	A3
MATERIAL:	Weight		SB00794A02	
Steel galvanised	3.2kg		SCALE:1:5	SHEET 79 OF 84

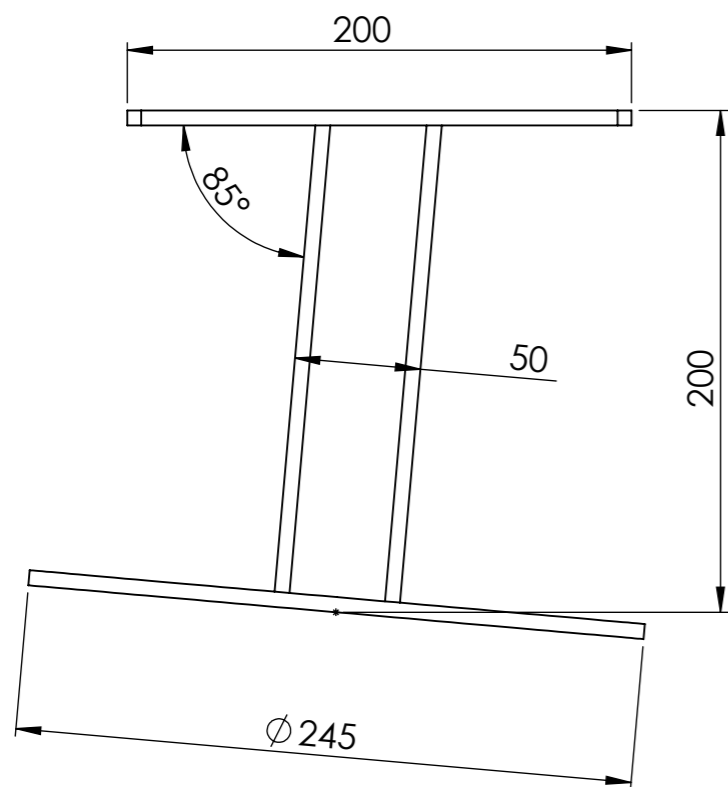
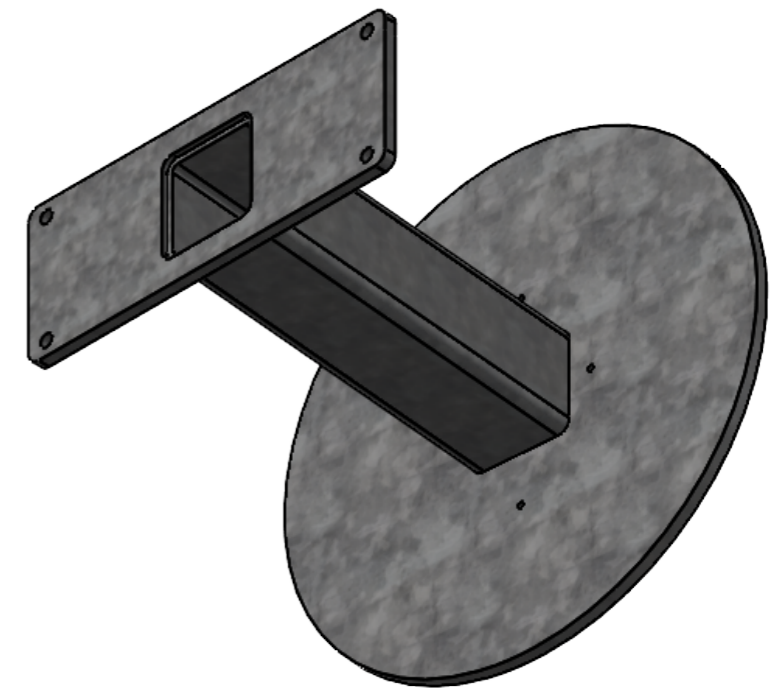
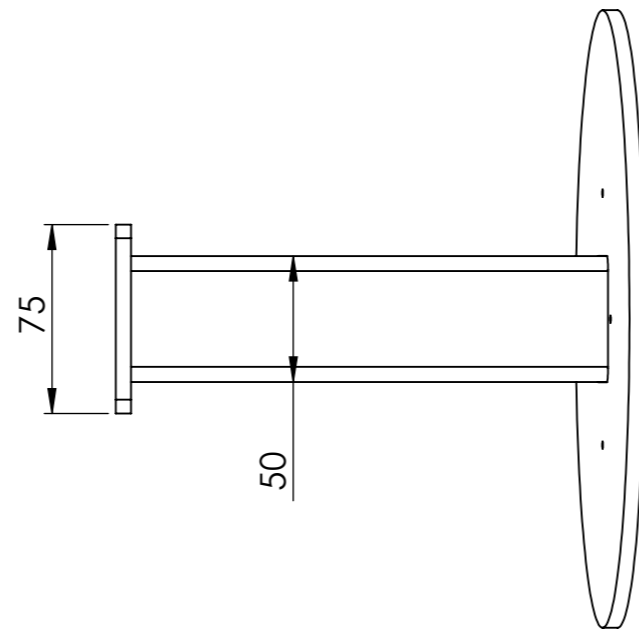
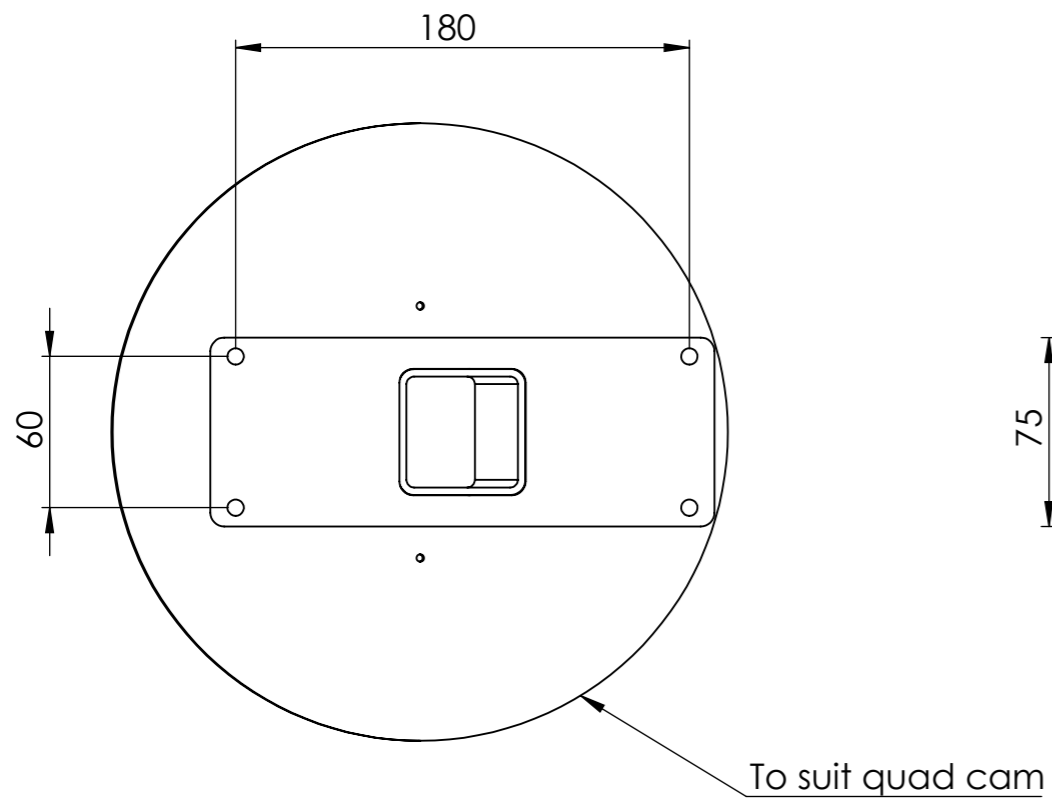

UNLESS OTHERWISE SPECIFIED: DIMENSIONS ARE IN MILLIMETERS	PROPRIETARY AND CONFIDENTIAL THE INFORMATION CONTAINED IN THIS DRAWING IS THE SOLE PROPERTY OF SEE SECURITY PTY LTD. ANY REPRODUCTION IN PART OR AS A WHOLE WITHOUT THE WRITTEN PERMISSION OF SEE SECURITY PTY LTD IS PROHIBITED.	DEBUR AND BREAK SHARP EDGES	DO NOT SCALE DRAWING	REVISION
FINISH:				
NAME	SIGNATURE	DATE		
DRAWN	ADC	14/10/2016		
MATERIAL:	Weight	DWG NO.		
Steel galvanised	3.5 kg	SB00804A01		A3
		SCALE:1:5	SHEET 80 OF 84	

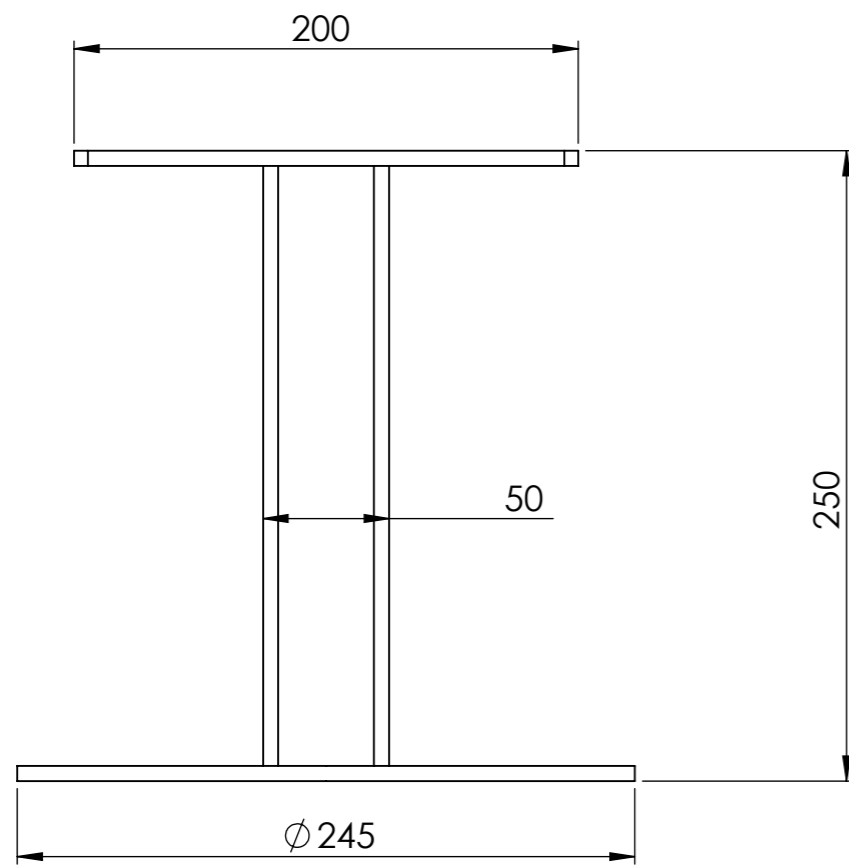
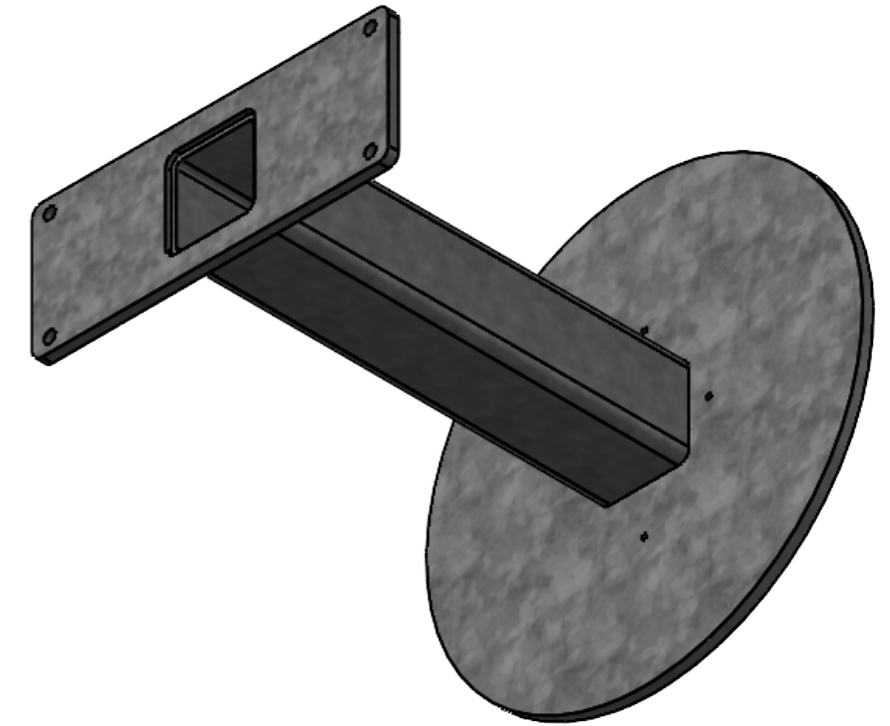
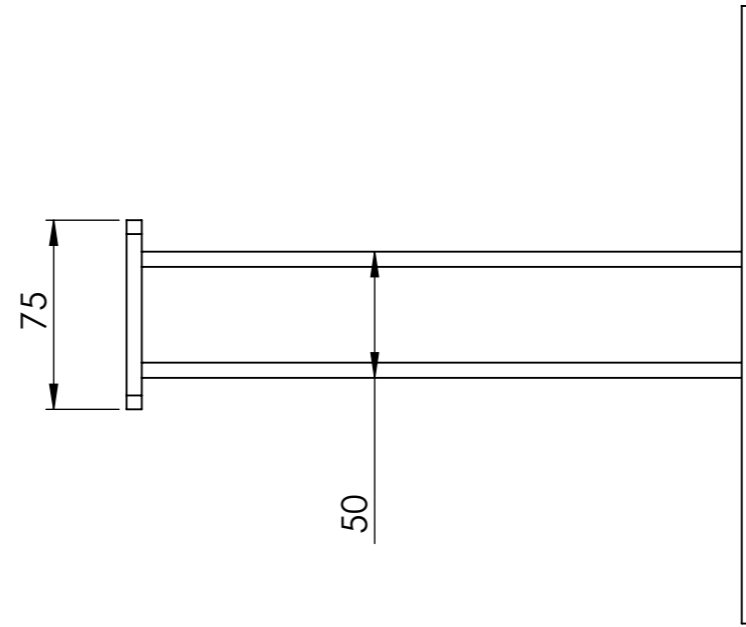
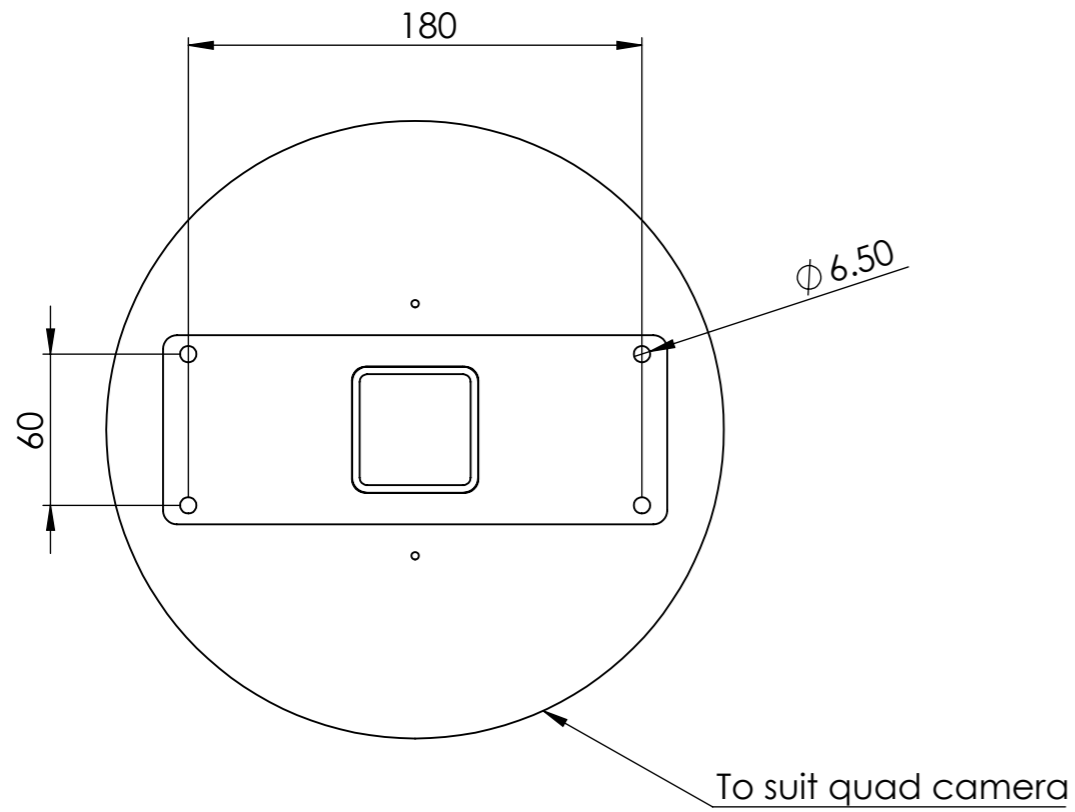

UNLESS OTHERWISE SPECIFIED: DIMENSIONS ARE IN MILLIMETERS	PROPRIETARY AND CONFIDENTIAL THE INFORMATION CONTAINED IN THIS DRAWING IS THE SOLE PROPERTY OF SEE SECURITY PTY LTD. ANY REPRODUCTION IN PART OR AS A WHOLE WITHOUT THE WRITTEN PERMISSION OF SEE SECURITY PTY LTD IS PROHIBITED.	DEBUR AND BREAK SHARP EDGES	DO NOT SCALE DRAWING	REVISION
FINISH:			 SEE SECURITY <small>SECURITY & EQUIPMENT ENG. SERVICES</small>	
NAME	SIGNATURE	DATE		
DRAWN	ADC	14/10/2016		
MATERIAL:	Weight	DWG NO.		
Steel galvanised	3.7kg	SB00804A02		A3
		SCALE:1:5	SHEET 81 OF 84	

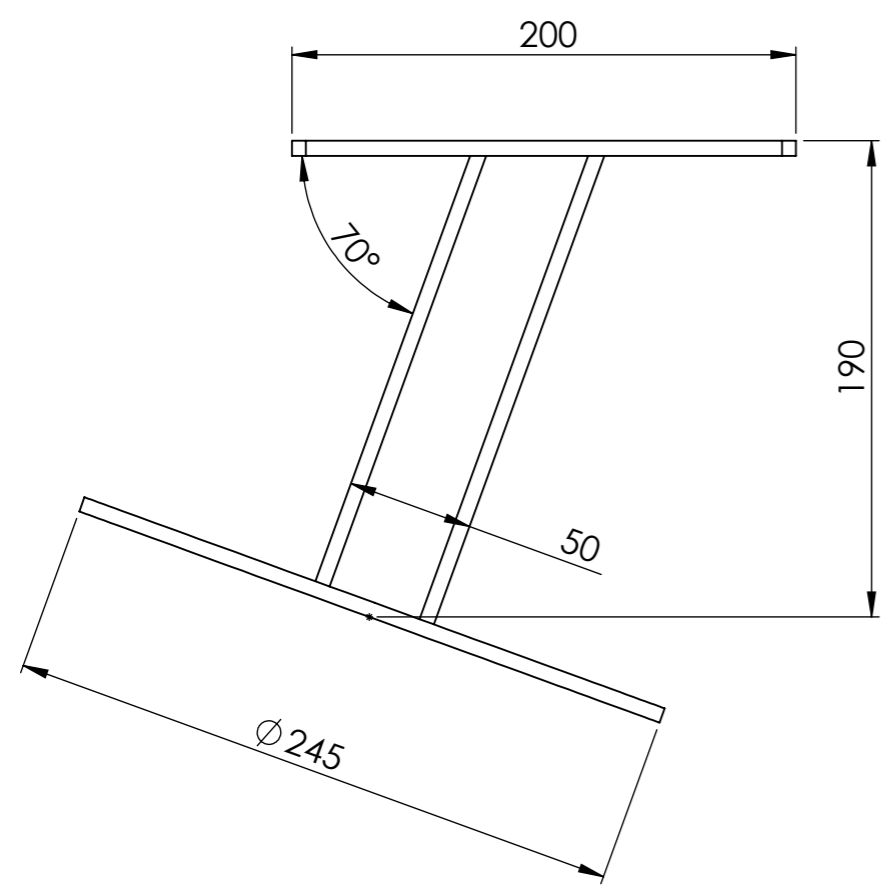
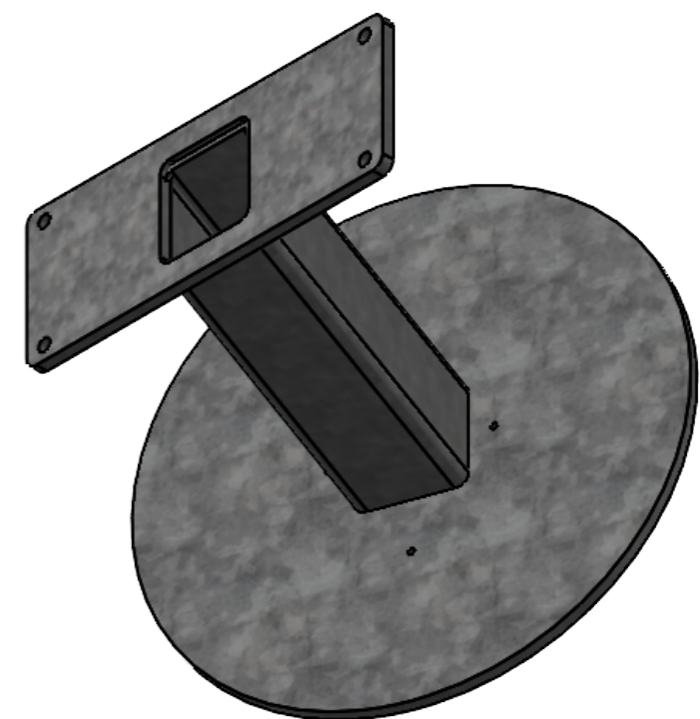
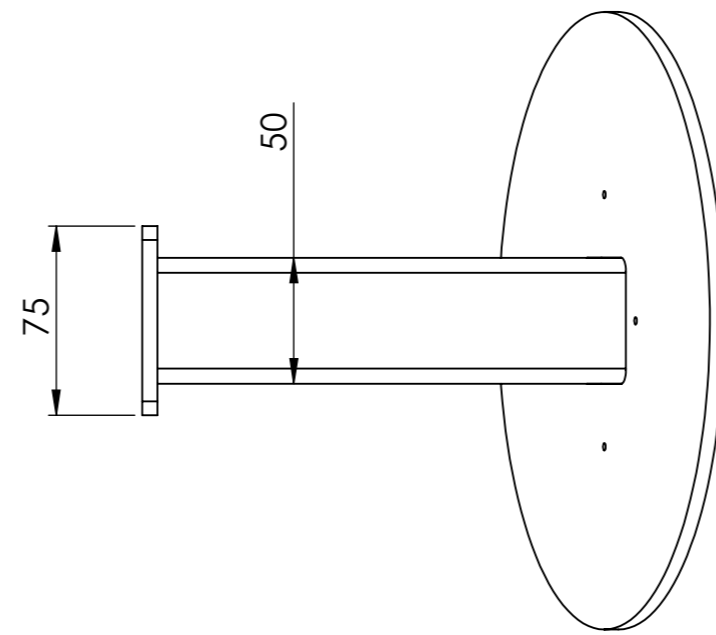
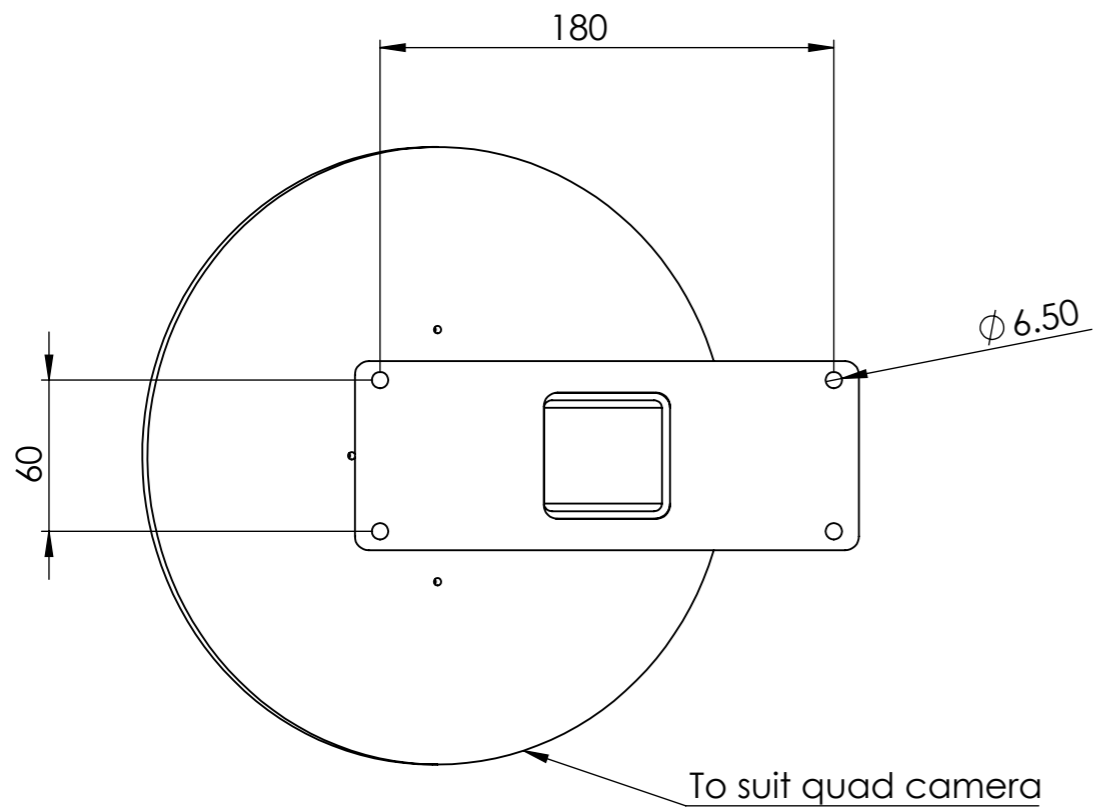

UNLESS OTHERWISE SPECIFIED: DIMENSIONS ARE IN MILLIMETERS	PROPRIETARY AND CONFIDENTIAL THE INFORMATION CONTAINED IN THIS DRAWING IS THE SOLE PROPERTY OF SEE SECURITY PTY LTD. ANY REPRODUCTION IN PART OR AS A WHOLE WITHOUT THE WRITTEN PERMISSION OF SEE SECURITY PTY LTD IS PROHIBITED.	DEBUR AND BREAK SHARP EDGES	DO NOT SCALE DRAWING	REVISION
FINISH:			 SEE SECURITY SECURITY & EQUIPMENT END. OFFERS	
NAME	SIGNATURE	DATE		
DRAWN	ADC	14/10/2016	DWG NO.	A3
MATERIAL:	Weight		SB00804A04	
Steel galvanised	3.5kg		SCALE:1:5	SHEET 82 OF 84

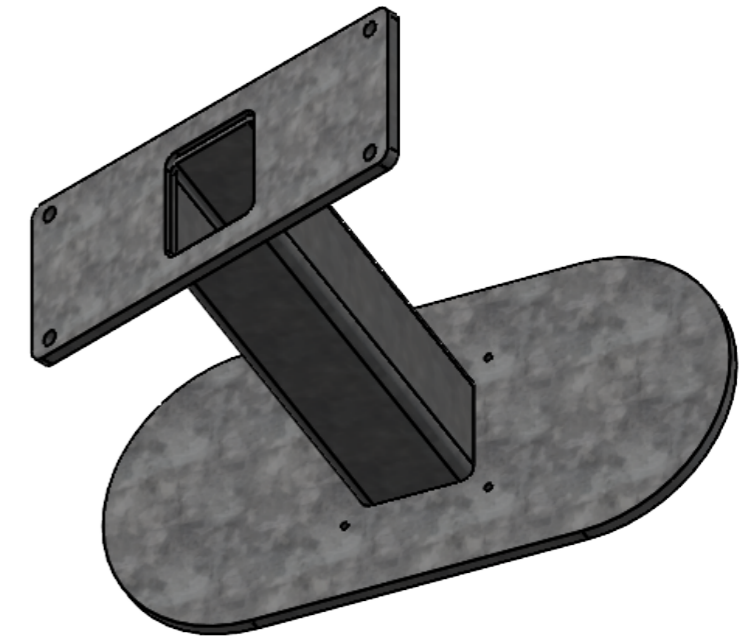
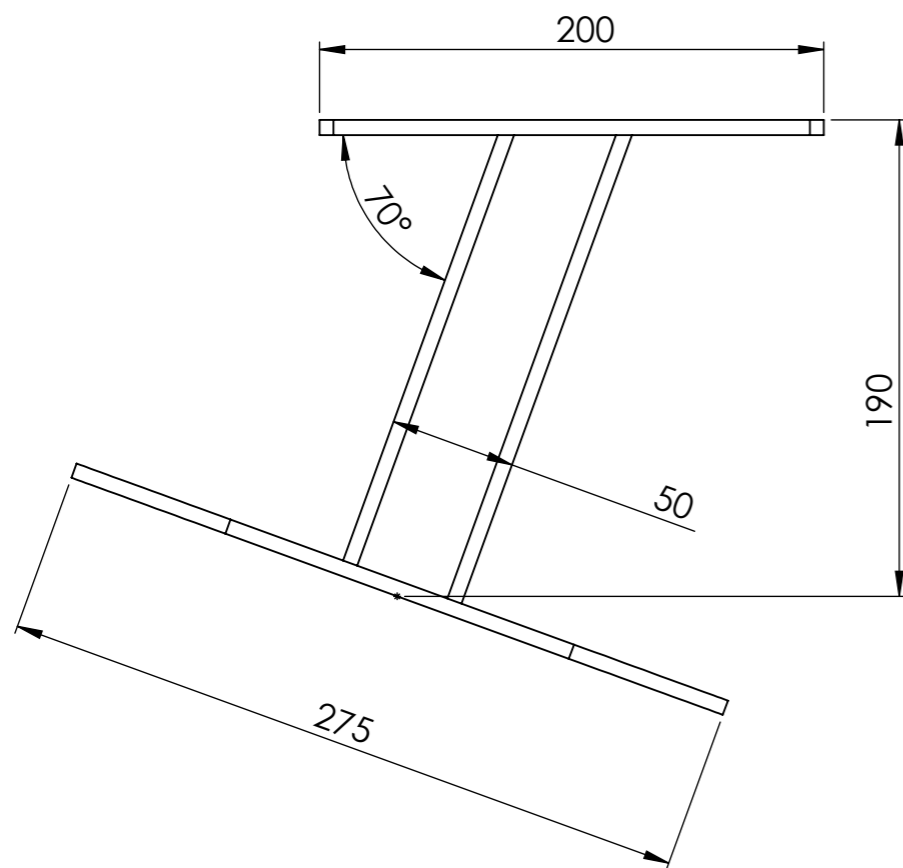
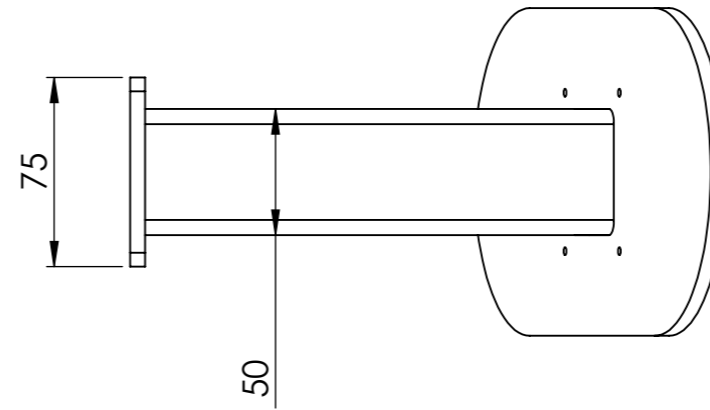
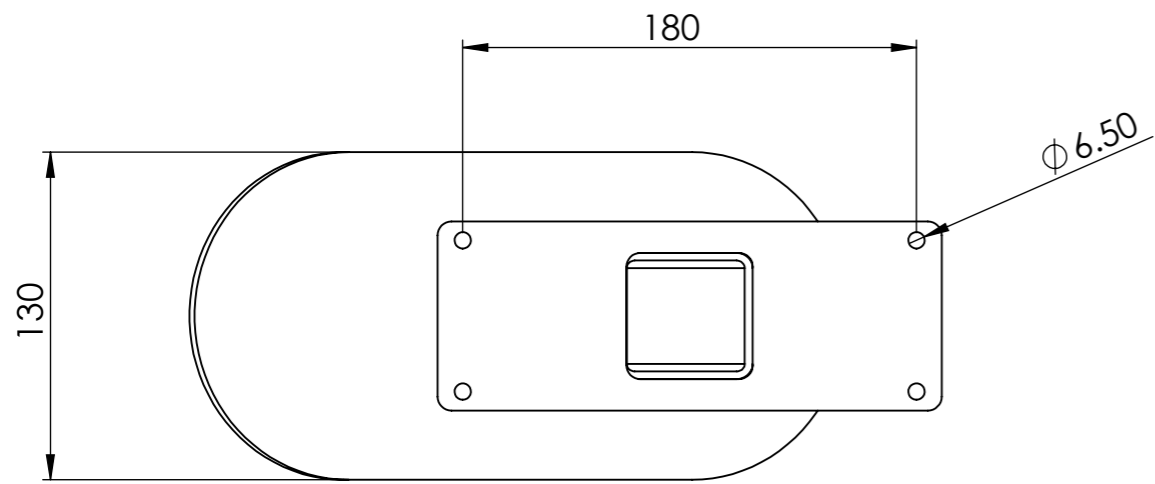

UNLESS OTHERWISE SPECIFIED: DIMENSIONS ARE IN MILLIMETERS	PROPRIETARY AND CONFIDENTIAL THE INFORMATION CONTAINED IN THIS DRAWING IS THE SOLE PROPERTY OF SEE SECURITY PTY LTD. ANY REPRODUCTION IN PART OR AS A WHOLE WITHOUT THE WRITTEN PERMISSION OF SEE SECURITY PTY LTD IS PROHIBITED.	DEBUR AND BREAK SHARP EDGES	DO NOT SCALE DRAWING	REVISION
FINISH:				
NAME	SIGNATURE	DATE		
DRAWN	ADC	14/10/2016		
MATERIAL:	Weight	DWG NO.		
Steel galvanised	2.8kg	SB00804A05		A3
		SCALE:1:5	SHEET 83 OF 84	

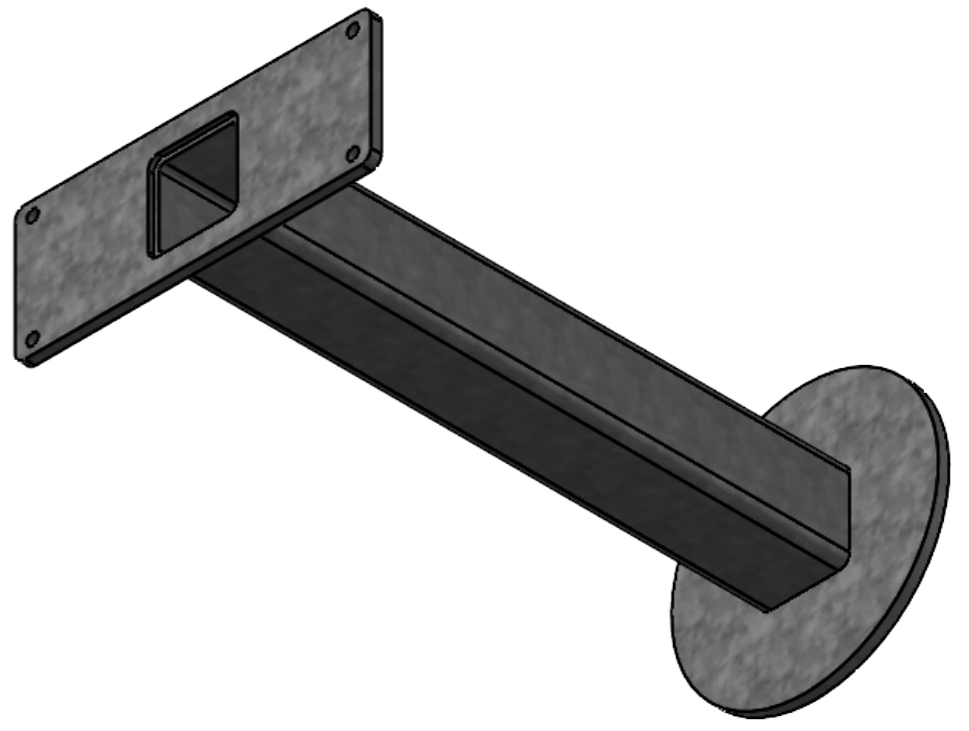
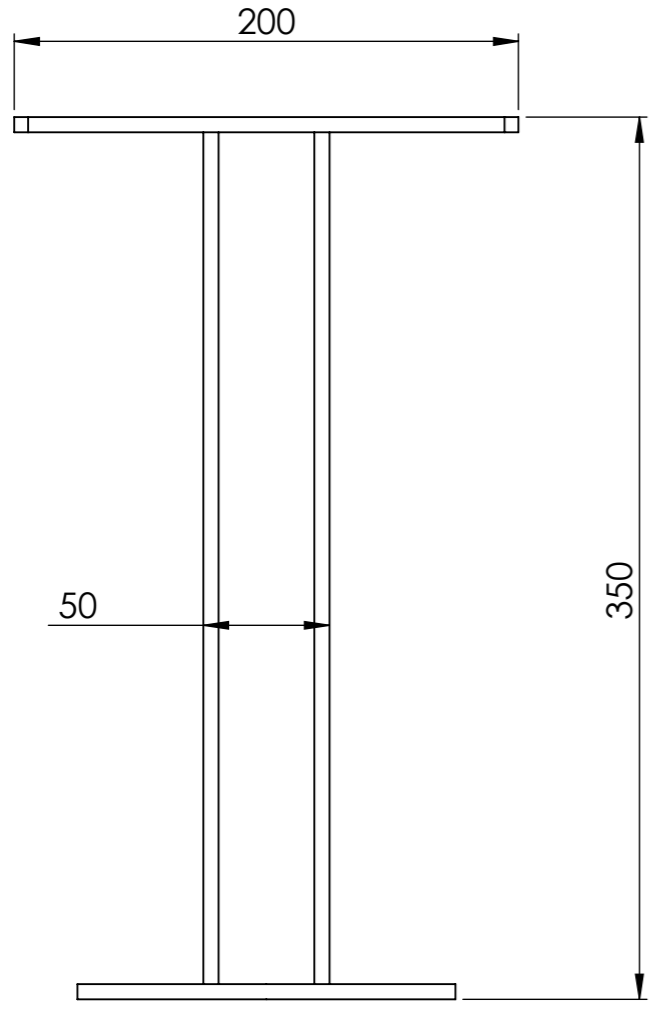
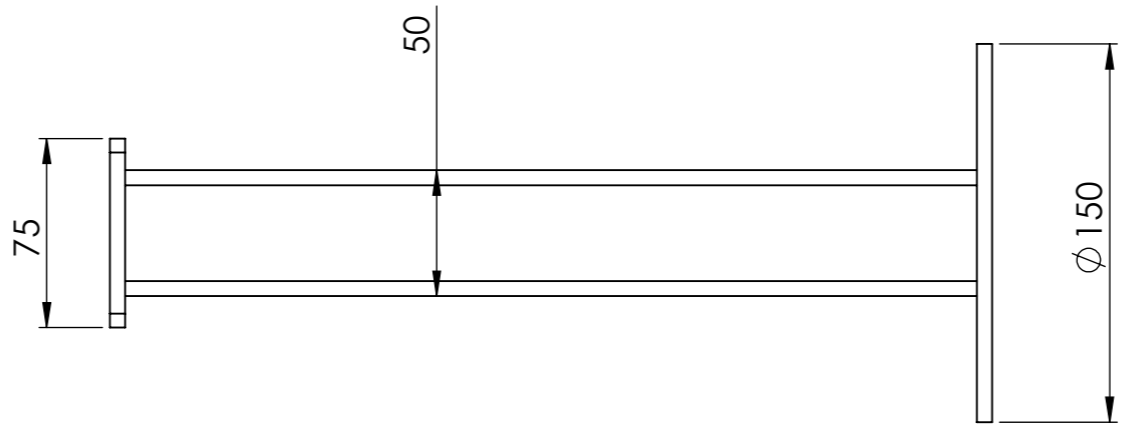
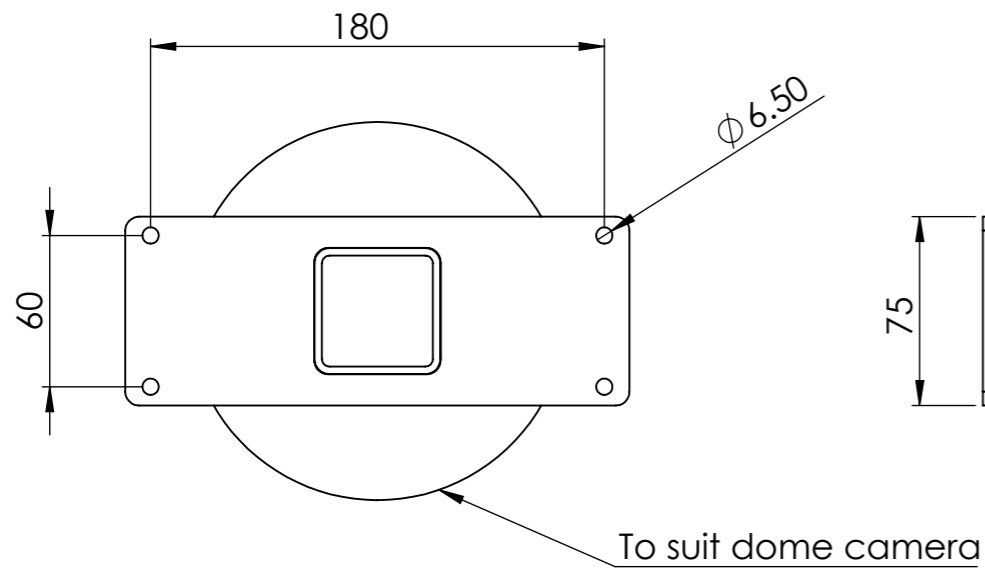

UNLESS OTHERWISE SPECIFIED: DIMENSIONS ARE IN MILLIMETERS	PROPRIETARY AND CONFIDENTIAL THE INFORMATION CONTAINED IN THIS DRAWING IS THE SOLE PROPERTY OF SEE SECURITY PTY LTD. ANY REPRODUCTION IN PART OR AS A WHOLE WITHOUT THE WRITTEN PERMISSION OF SEE SECURITY PTY LTD IS PROHIBITED.	DEBUR AND BREAK SHARP EDGES	DO NOT SCALE DRAWING	REVISION
FINISH:				
NAME	SIGNATURE	DATE		
DRAWN	ADC	14/10/2016		
MATERIAL:	Weight	DWG NO.		
Steel galvanised	2.8kg	SB00804A08		A3
		SCALE:1:5	SHEET 84 OF 84	